

INTERLINE PRO LINE

SUMATRA 6.00x3.13x1.38 m

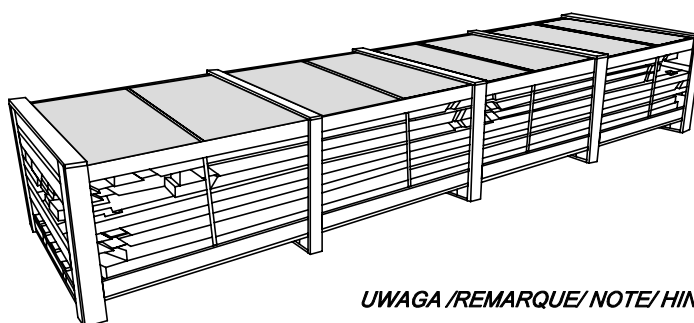
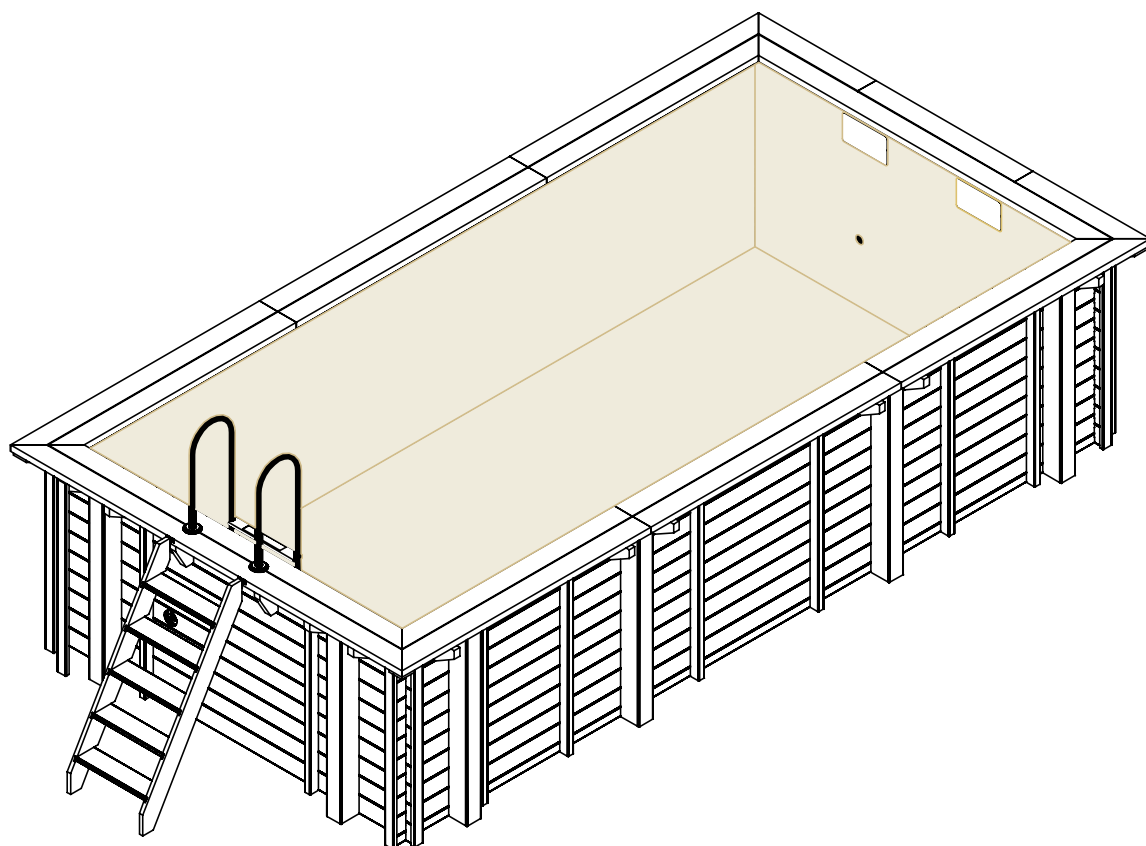

UWAGA / REMARQUE / NOTE / HINWEIS / LETOP

- PL** Maksymalna wysokość słupa wody ~ 1.20 m
- FR** Niveau maximum de la colonne d'eau ~ 1.20 m
- GB** The maximum water column level ~ 1.20 m
- DE** Maximaler Wasserstand ~ 1.20 m
- NL** Maximum niveau waterkolom ~ 1.20 m

- PL** Instrukcja montażu
- FR** Notice de montage
- GB** Assembly instructions
- DE** Montageanleitungen
- NL** Montage-instructies

- PL** Objętość wody w basenie 17.1 m³
- FR** Le volume de l'eau dans la piscine 17.1 m³
- GB** Water capacity in the pool 17.1 m³
- DE** Wasserkapazität im Pool 17.1 m³
- NL** Watercapaciteit in het zwembad 17.1 m³

(PL) Instrukcja montażu

(GB) Assembly instructions

(DE) Montageanleitungen

(FR) Notice de montage

(NL) Montage-instructies



(PL) Przed przystąpieniem do montażu zapoznaj się z instrukcją.

(FR) Avant le montage lisez attentivement la notice.

(GB) Read carefully pool installation manual before the installation.

(DE) Lesen Sie das Pool-Installationshandbuch vor der Installation sorgfältig durch.

(NL) Lees zorgvuldig de handleiding van het zwembad voordat u met de installatie begint.

UWAGA / REMARQUE / NOTE / HINWEIS / OPMERKING

Instrukcja, którą posiadacie Państwo w ręku pokazuje krok po kroku w jaki sposób dokonać właściwego montażu basenu. Dołożyliśmy wszelkich starań, aby przygotować materiały jak najbardziej odzwierciedlające stan faktyczny i wygląd

(PL) poszczególnych elementów. Jednak proszę pamiętać, że wszelkie rysunki mają charakter poglądowy i istnieje możliwość, że poszczególne elementy dostarczone w Państwa zestawie w rzeczywistości mogą odbiegać wyglądem od ich wizualizacji graficznej zawartej w instrukcji.

Le manuel que vous avez entre les mains montre étape par étape comment assembler correctement la piscine. Nous avons fait tous les efforts pour préparer les documents reflétant autant que possible l'état réel et l'apparence

(FR) des éléments particuliers. Pourtant, il faut savoir que tous les dessins sont présentés à titre de référence et qu'il est possible que les éléments singuliers fournis dans votre kit puissent différer en apparence de leur visualisation graphique incluse dans le manuel.

This manual presents the correct assembly procedure for the swimming pool, step by step. We have undertaken all possible efforts to make sure that the materials are as close to the actual items and present their layout as closely

(GB) as possible. Please remember, however, that all figures are indicative only and individual elements delivered in your set may be different than their graphical visualisations presented in the manual.

Die Ihnen vorliegende Anleitung erläutert Ihnen Schritt für Schritt, wie das Schwimmbecken korrekt montiert wird. Wir haben alles daran gesetzt, die

(DE) Unterlagen bestmöglich an den tatsächlichen Zustand und das Aussehen der einzelnen Teile anzupassen. Bitte bedenken Sie jedoch, dass alle Zeichnungen nur zu Anschauungszwecken dienen. Deshalb kann es sein, dass einzelne Teile in Ihrem Set anders aussehen, als in der graphischen Visualisierung in der Anleitung.

Deze handleiding presenteert stap voor stap hoe u het zwembad op de juiste manier kunt monteren. We hebben er alles aan gedaan om een handleiding te maken die een realistisch beeld weergeeft van de montage en onderdelen.

(NL) Houd echter wel rekening mee dat alle tekeningen alleen ter referentie dienen en dat het mogelijk is dat de afzonderlijke elementen in uw set kunnen afwijken van de grafische tekeningen in deze handleiding.

(PL) Instrukcja montażu

(GB) Assembly instructions

(DE) Montageanleitungen

(FR) Notice de montage

(NL) Montage-instructies



(PL) Przed przystąpieniem do montażu zapoznaj się z instrukcją. * Bez wylewki betonowej.
(FR) Avant le montage lisez attentivement la notice. * Sans dalle de béton.
(GB) Read carefully pool installation manual before the installation. * Without concrete base.
(DE) Lesen Sie das Pool-Installationshandbuch vor der Installation sorgfältig durch. * Ohne Betonbasis.
(NL) Lees zorgvuldig de handleiding van het zwembad voordat u met de installatie begint. * Zonder betonnen basis.

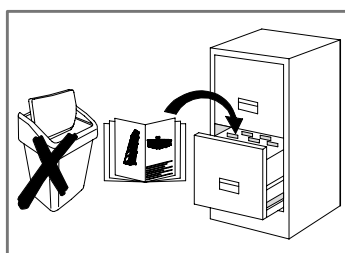
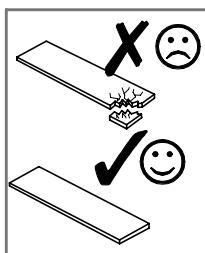
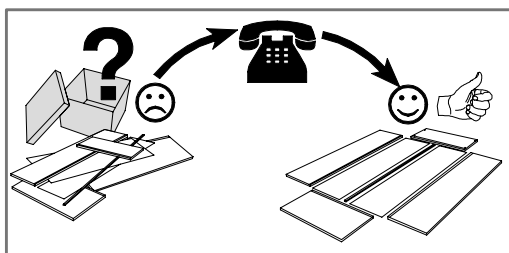
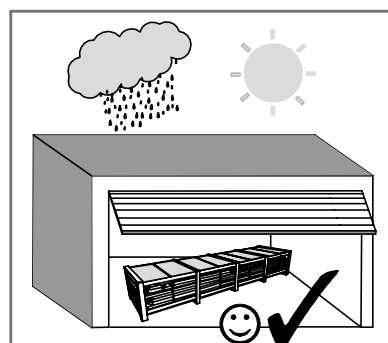
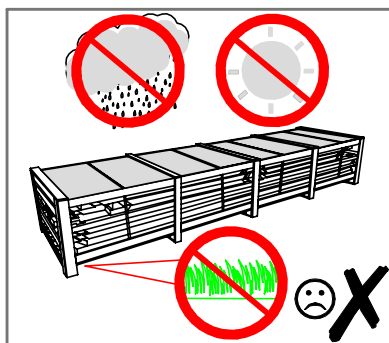
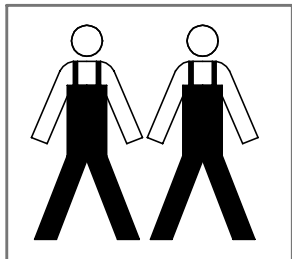
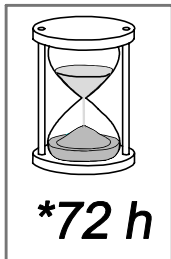

UWAGA / REMARQUE / NOTE / HINWEIS / OPMERKING

(PL) Montaż wykonać w przeciągu 3 dni od rozpakowania struktury.
(FR) Le montage de la structure doit être terminé dans un délai de 3 jours suivant l'ouverture de l'emballage.
(GB) Installation should be finished within 3 days from opening the package.
(DE) Die Installation sollte innerhalb von 3 Tagen nach dem Öffnen des Pakets abgeschlossen sein.
(NL) De installatie moet binnen 3 dagen na opening van het pakket worden voltooid.



UWAGA / REMARQUE / NOTE / HINWEIS / OPMERKING

(PL) Brak corocznej konserwacji struktury powoduje utratę gwarancji.
(FR) En cas de défaut d'entretien annuel de la structure, la garantie est invalidée.
(GB) Lack of once a year conservation of the structure causes loss of warranty.
(DE) Der Mangel an einmal jährlichem Schutz der Struktur verursacht einen Garantieverlust.
(NL) Het uitblijven van onderhoud aan de constructie eenmaal per jaar zorgt voor verval van de garantie.



UWAGA / REMARQUE / NOTE / HINWEIS / OPMERKING

(PL) Nie pozostawiać dzieci bez nadzoru!
(FR) Ne laissez pas les enfants sans surveillance!
(GB) Do not leave children unattended!
(DE) Lassen Sie Kinder nicht unbeaufsichtigt!
(NL) Laat kinderen niet zonder toezicht achter!

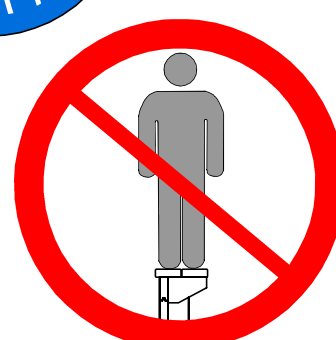
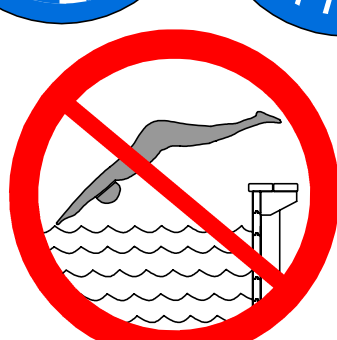

Standardowa gwarancja - 8 lat

Warunek : coroczne zabezpieczanie struktury drewnianej środkami do drewna dostępnymi na rynku.

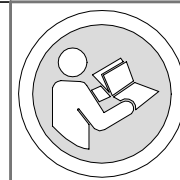

Wyłużona gwarancja - 10 lat

- (PL)** Warunek: coroczne zabezpieczanie struktury drewnianej (wszystkich widocznych/dostępnych elementów) dedykowanym środkiem rekomendowanym przez producenta - LAZURA OLEJNA (zapytaj swojego dostawcę o szczegóły). Stosuj się do zaleceń zawartych na etykiecie produktu. Warunkiem uwzględnienia gwarancji jest zachowanie kopii dokumentów zakupu wskazanego środka do konserwacji od pierwszego roku użytkowania.

Standard warranty - 8 years

Conditions: Maintain annual conservation of the wooden structure with wood protection agents available on the market.

Extended warranty - 10 years

- (GB)** Conditions: Maintain annual conservation of the wooden structure (all visible/available elements) with a dedicated agent recommended by the manufacturer - NATURAL OIL WOODSTAIN PROTECTION (ask your supplier for details). Follow the instructions on the product label. For warranty recognition, keep copies of the purchase documents of the indicated wood protection agent from the first year of use.

Standard Gewährleistung - 8 Jahre

Bedingungen: Pflegen Sie die Holzstruktur jährlich mit auf dem Markt erhältlichen Holzschutzmitteln.

Erweiterte Gewährleistung - 10 Jahre

(DE) Bedingungen: Pflegen Sie die Holzstruktur (alle sichtbaren / verfügbaren Elemente) jährlich mit einem vom Hersteller empfohlenen Holzschutzmittel - NATURAL OIL WOODSTAIN PROTECTION (fragen Sie Ihren Lieferanten nach weiteren Informationen). Befolgen Sie die Anweisungen auf dem Produktetikett. Bewahren Sie Kopien der Kaufdokumente für das angegebene Holzschutzmittel ab dem ersten Jahr der Verwendung für die Gewährleistung auf.

Standaardgarantie - 8 jaar

Voorwaarden: Onderhoud jaarlijks de houten structuur met op de markt verkrijgbare houtbeschermingsmiddelen.

Verlengde garantie - 10 jaar

(NE) Voorwaarden: Onderhoud jaarlijks de houten structuur (alle zichtbare / beschikbare elementen) met een door de fabrikant aanbevolen houtbeschermingsmiddel - NATURAL OIL WOODSTAIN PROTECTION (vraag uw leverancier voor meer informatie). Volg de instructies op het productetiket. Bewaar kopieën van de aankoopdocumenten van het aangegeven houtbeschermingsmiddel vanaf het eerste jaar van gebruik voor de garantie.

(PL) Uwaga : Brak regularnej konserwacji struktury powoduje utratę gwarancji !

(DE) Bitte beachten Sie: Wenn die Struktur nicht jährlich gewartet wird, erlischt die Gewährleistung!

(GB) Please note: Lack of once a year conservation of the structure causes loss of warranty!

(NL) Let op: Ingebrekestelling van jaarlijks onderhoud aan de constructie veroorzaakt verval van garantie!



- PL** Sprawdź ilość oraz czy elementy nie są uszkodzone.
- FR** Vérifier que les éléments soient au complet (quantité) et qu'ils ne soient pas endommagés (qualité).
- GB** Check quantity of elements and if they are not faulty.
- DE** Überprüfen Sie die Anzahl der Elemente und ob sie nicht fehlerhaft sind.
- NL** Controleer de hoeveelheid elementen en of deze niet defect zijn.

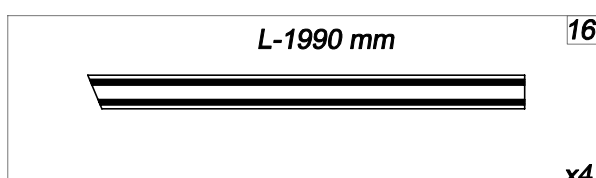
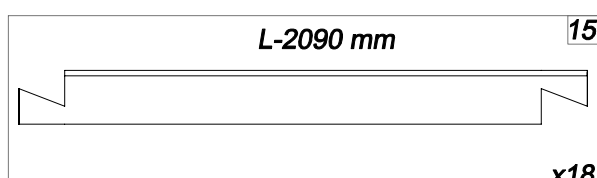
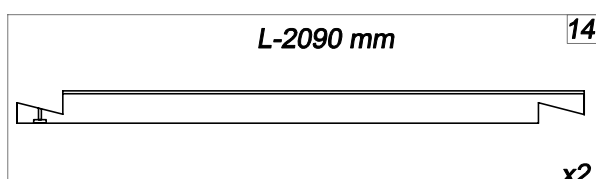
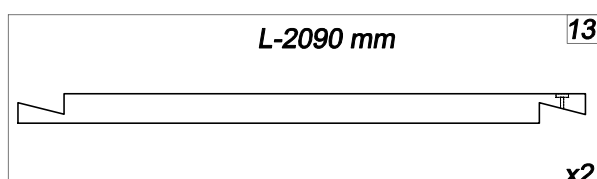
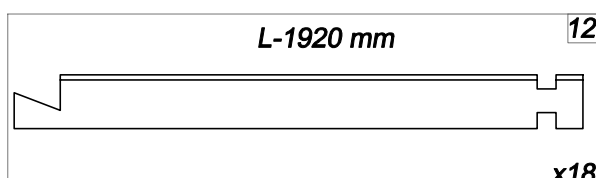
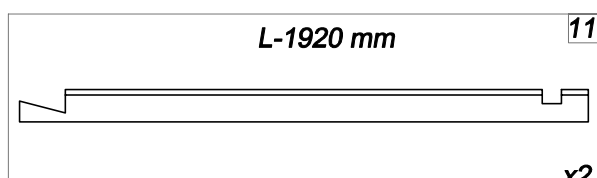
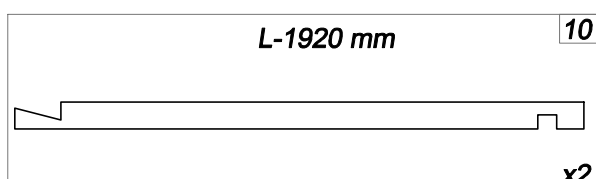
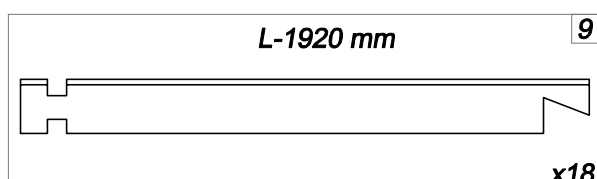
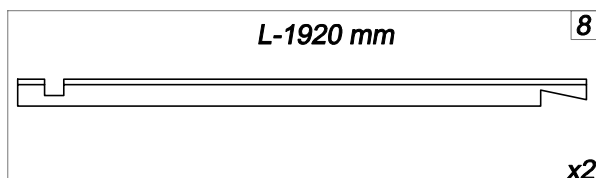
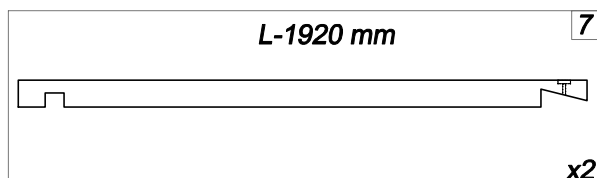
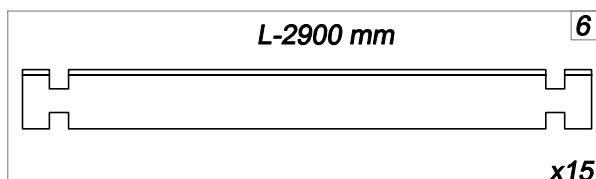
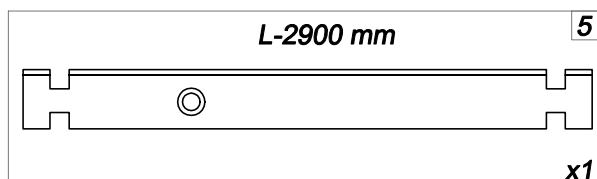
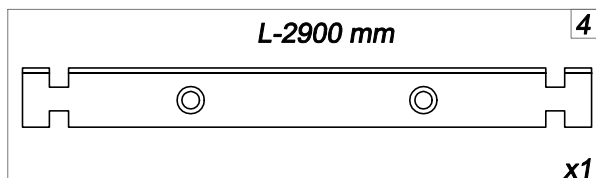
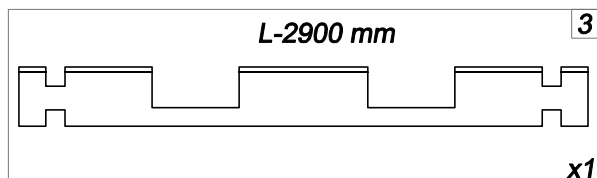
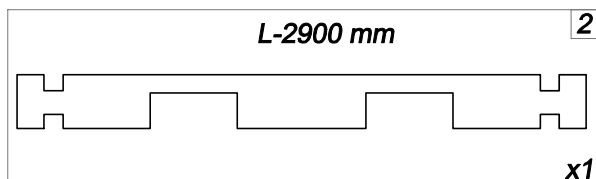
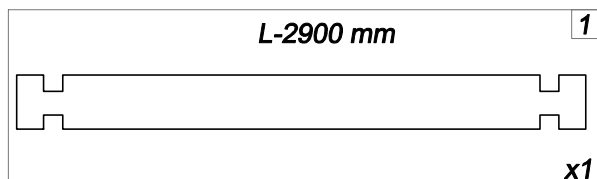
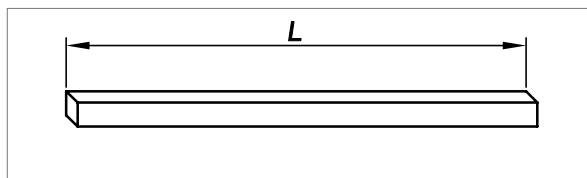



- PL** Sprawdź ilość oraz czy elementy nie są uszkodzone.
- FR** Vérifier que les éléments soient au complet (quantité) et qu'ils ne soient pas endommagés (qualité).
- GB** Check quantity of elements and if they are not faulty.
- DE** Überprüfen Sie die Anzahl der Elemente und ob sie nicht fehlerhaft sind.
- NL** Controleer de hoeveelheid elementen en of deze niet defect zijn.

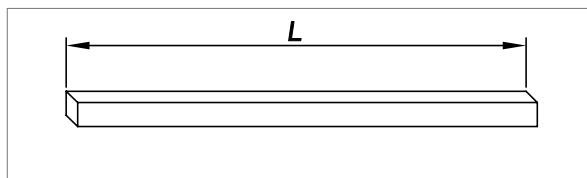

L-1840 mm **17**

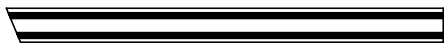

x4

L-2000 mm **18**

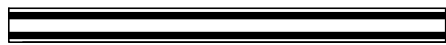

x4

L-3130 mm **19**



x1

L-2830 mm **20**



x2

L-938 mm **21**

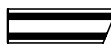

x1

L-938 mm **22**



x1

L-1255 mm **23**

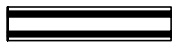

x1

L-1588 mm **24**

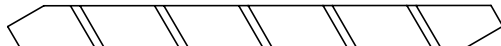

x1

L-1588 mm **25**

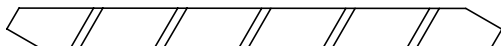

x1

L-575 mm **26**

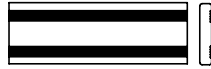

x5

L-835 mm **27**

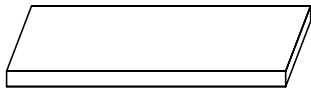

x1

L-1330 mm **28**

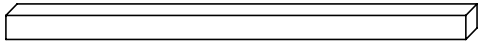

x17

L-1285 mm **29**

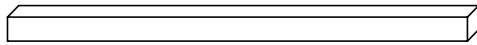

x1

L-1330 mm **30**

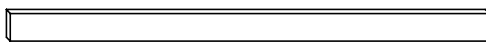

x24

L-1330 mm **31**

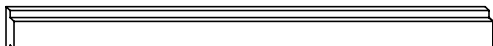

x12

L-1330 mm **32**



x8

PL Elementy

GB Elements

DE Elemente

FR Les éléments

NL Elementen



PL Sprawdź ilość oraz czy elementy nie są uszkodzone.

FR Vérifier que les éléments soient au complet (quantité) et qu'ils ne soient pas endommagés (qualité).

GB Check quantity of elements and if they are not faulty.

DE Überprüfen Sie die Anzahl der Elemente und ob sie nicht fehlerhaft sind.

NL Controleer de hoeveelheid elementen en of deze niet defect zijn.

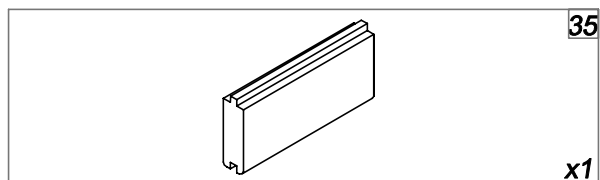
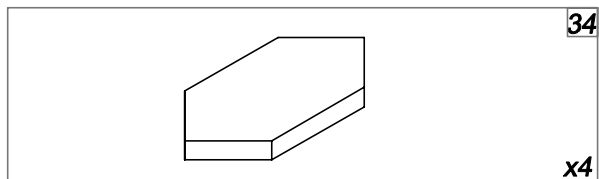
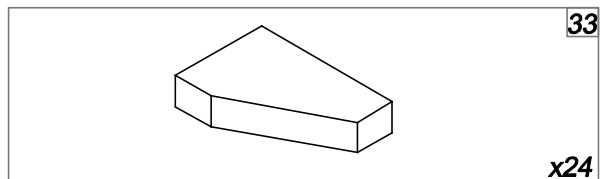
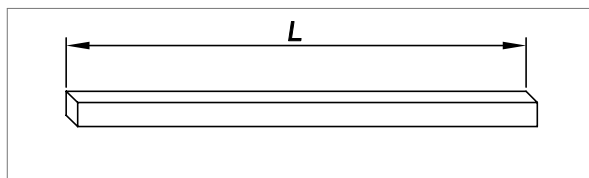

PL Okucia i osprzęt

GB Fittings and equipment

DE Ausstattung und Ausrüstung

FR Quincaillerie et équipement

NL Fittingen en apparatuur



PL Sprawdź ilość.

FR Vérifiez la quantité.

GB Check quantity.

DE Überprüfen Sie die Anzahl.

NL Controleer de hoeveelheid.

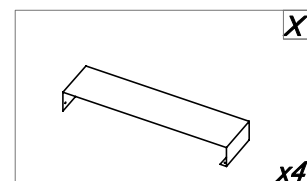
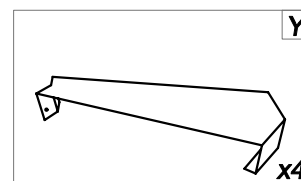
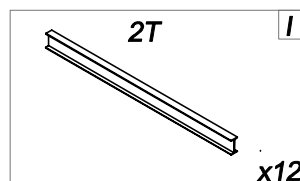
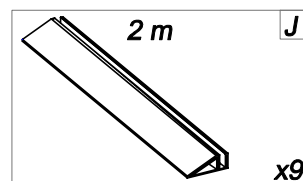
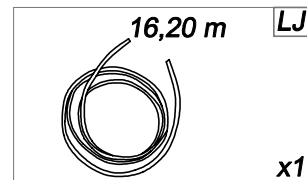
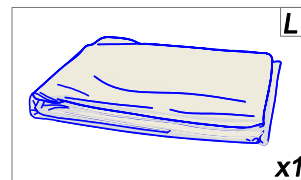
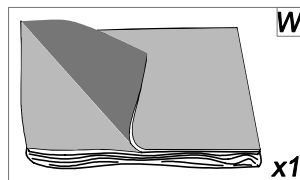
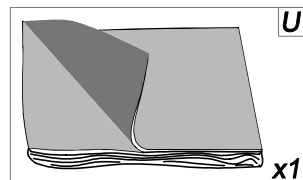
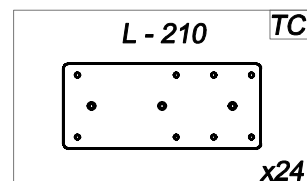
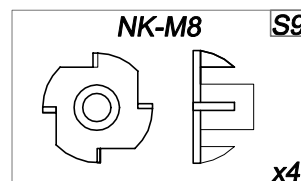
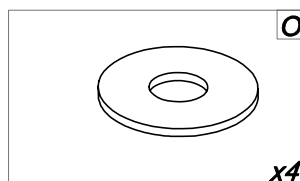
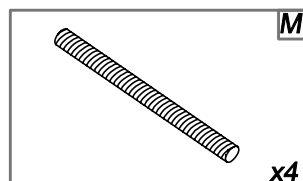
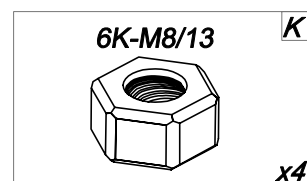
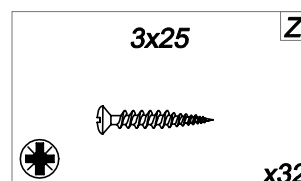
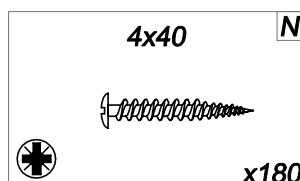
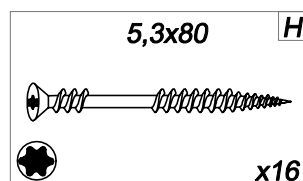
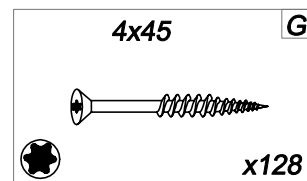
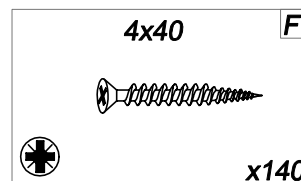
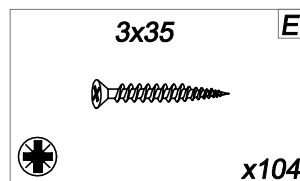
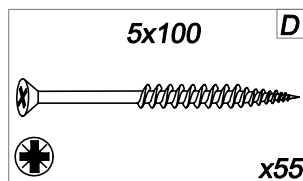
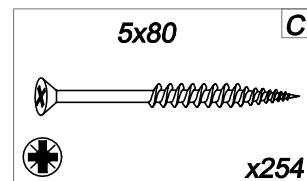
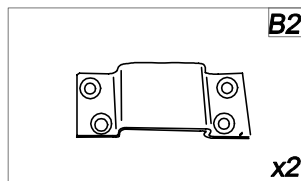
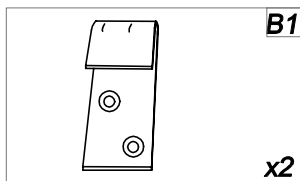
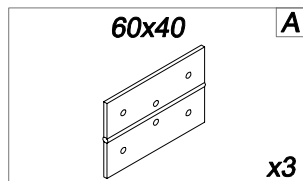

PL Okucia i osprzęt

GB Fittings and equipment

DE Ausstattung und Ausrüstung

FR Quincaillerie et équipement

NL Fittingen en apparatuur



- PL** Sprawdź ilość.
- FR** Vérifiez la quantité.
- GB** Check quantity.
- DE** Überprüfen Sie die Anzahl.
- NL** Controleer de hoeveelheid.

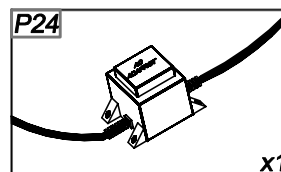
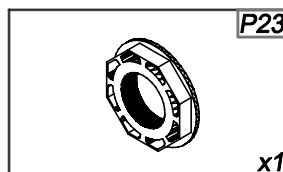
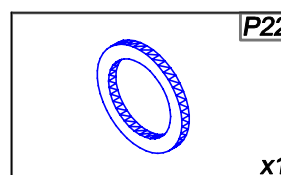
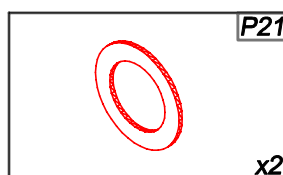
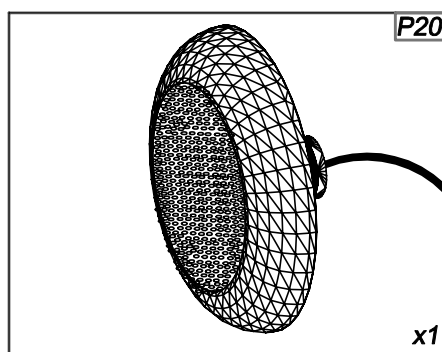
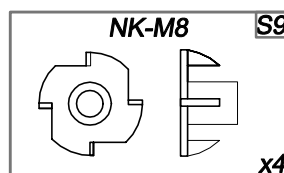
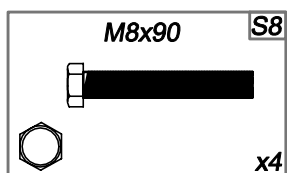
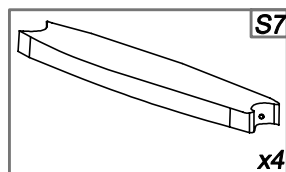
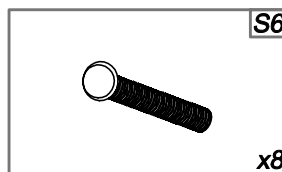
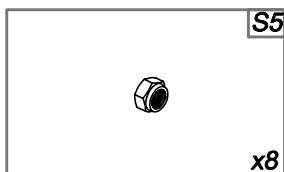
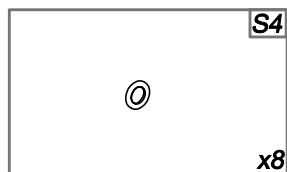
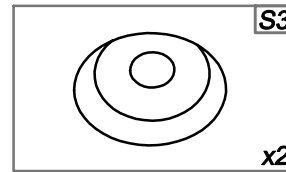
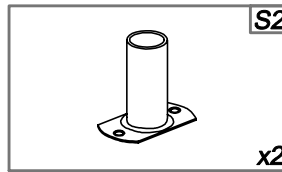
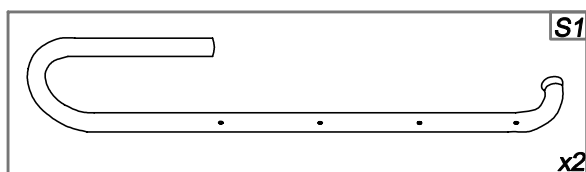

PL Skimmer i dysze

GB Skimmer and nozzles

DE Skimmer und Düsen

FR Le skimmer et la buse de refoulement

NL Skimmer en jet straal



- PL** Sprawdź ilość.
- FR** Vérifiez la quantité
- GB** Check quantity.
- DE** Überprüfen Sie die Anzahl.
- NL** Controleer de hoeveelheid.

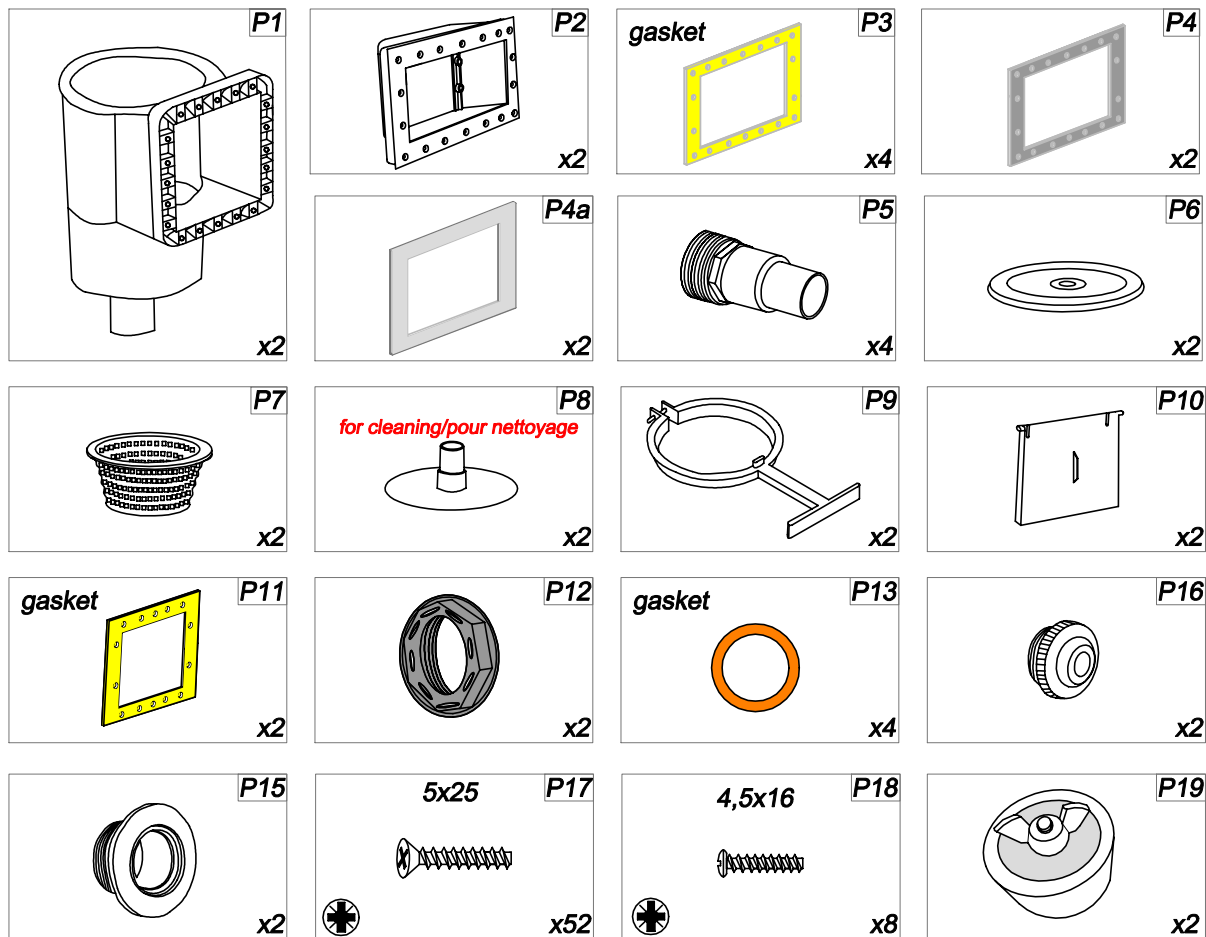

UWAGA / REMARQUE / NOTE / HINWEIS / OPMERKING

- PL** Poszczególne elementy osprzętu w instrukcji mogą się nieznacznie różnić od faktycznie dostarczonych.
- FR** Il est possible que certains éléments présentés dans la notice de montage ne soient pas exactement identiques aux éléments livrés.
- GB** It is possible that some elements of equipment in the assembly instruction will not correspond exactly to those supplied
- DE** Es ist möglich, dass einige Elemente der Ausrüstung in der Montageanleitung nicht genau mit den gelieferten übereinstimmen.
- NL** Het is mogelijk dat sommige apparatuuronderdelen in de handleidinge niet precies overeenkomen met de geleverde onderdelen.

UWAGA / REMARQUE / NOTE / HINWEIS / OPMERKING

- PL** Widok po zmontowaniu.
- FR** Controlez après montage.
- GB** View after assembly.
- DE** Ansicht nach der Montage.
- NL** Controleer na de montage.

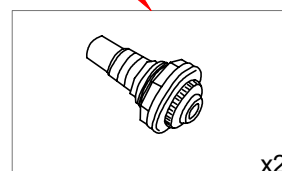
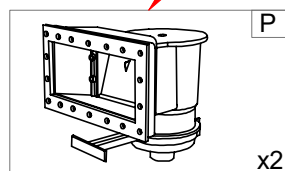

(PL) Opcja
(FR) Option

(GB) Option

(DE) Option

(NL) Optie



Zatyczka do dyszy – w celu przygotowania basenu do sezonu zimowego (w szczególności przy ryzyku zamarznięcia wody), zastosuj zatyczkę do dysz napływowych, odcinając dopływ wody do zestawu filtracyjnego. **Pozostaw dyszę w basenie, zamontuj zatyczkę pod wodą. Należy pamiętać również o odłączeniu zestawu filtracyjnego od źródła wody i dokładnym osuszeniu dyszy od strony zewnętrznej. Zaleca się także, aby z pompy jak i dołączonego filtra piaskowego na okres zimy (miejsca gdzie występują mrozy) usunąć pozostałości wody, w innym przypadku zamarzająca woda może dokonać zniszczenia całości zestawu.**

Bouchon pour la buse de refoulement – afin de préparer la piscine pour l'hiver (en particulier en cas de risque de gel de l'eau), veuillez utiliser le bouchon spécialement fourni avec le skimmer et destiné à fermer l'accès de l'eau au système de filtration. **Veuillez laisser la buse de refoulement dans la piscine, montez le bouchon sous l'eau. Il est également indispensable de déconnecter le système de filtration du point d'arrivée d'eau et de s'assurer que la partie de la buse de refoulement placée à l'extérieur de la piscine soit parfaitement sèche. En plus, il est conseillé de vider le reste de l'eau se trouvant dans la pompe et le filtre à sable surtout en période de gel. L'eau qui gèle à l'intérieur du système de filtration peut causer des dégâts et des dysfonctionnements.**

Rubber plug- in order to prepare the pool for the winter season (especially if there is a risk of freezing) put a plug into the inlet to shut off the access of water to the filtration system. **Inlet must remain in the pool. Fix the plug under water. Remember to disconnect the filtration set from the pool and dry the inlet (the part of inlet which is outside of the pool). For the winter season, it is recommended to get rid of water remaining in pump and sand filter, otherwise freezing water can cause devastation of the whole set.**

Stöpsel für die Düse – den Pool für die Wintersaison vorbereiten (insbesondere wegen der Gefahr des einfrierenden Wassers), verwenden Sie dazu die Zuflusssdüse. Schneiden Sie die Wasserzufuhr zu dem Filtersystem ab, nachdem Sie den Filter abgetrennt haben, sollten Sie auf die gründliche Trocknung der Düse von außen achten, und dass die Filteranlage von der Wasserquelle abgetrennt ist. **Lassen Sie die Düse in den Pool, installieren Sie den Stöpsel unter dem Wasser. Es wird auch empfohlen, aus dem Sandfilter sowie der Pumpe restliches Wasser zu entfernen (Stellen wo Frost entstehen kann), da sonst das gefrierende Wasser das komplette Filtersystem beschädigt.**

Rubberen stop - om de toegang van de inlaat (jet straal) voor het filtersysteem af te sluiten ter voorbereiding op het winterseizoen (vooral als er een risico bestaat op bevriezing van water). **De inlaat moet in het zwembad blijven. Bevestig de stop onder water. Let op dat u de het filtersysteem loskoppelt van het zwembad en de achterkant van de inlaat laat drogen en achterblijvend water te verwijderen, ter voorkoming van beschadiging in het filtersysteem door bevriezing van water.**

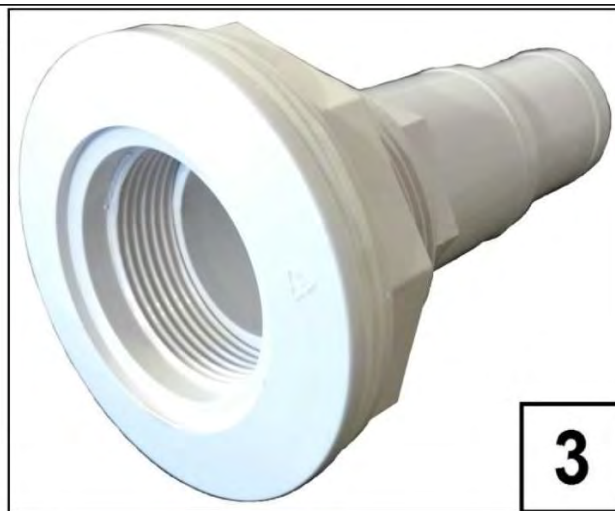
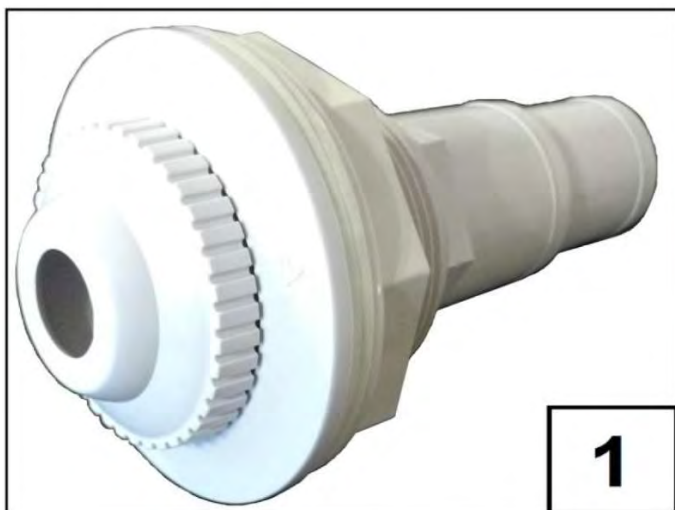

PL Narzędzia

GB Tools

DE Werkzeug

FR Les outils

NL Gereedschap

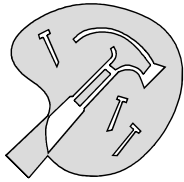

PL Przygotuj niezbędne narzędzia - niezawarte w zestawie.

FR Préparez les outils nécessaires - non inclus.

GB Prepare essential tools - not included.

DE Bereiten Sie das notwendige Werkzeug vor - nicht enthalten.

NL Bereid de benodigde hulpmiddelen voor - niet inbegrepen.

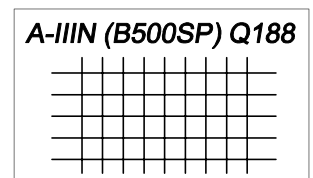
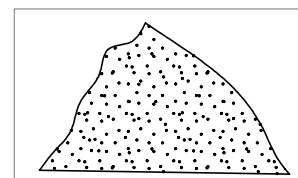
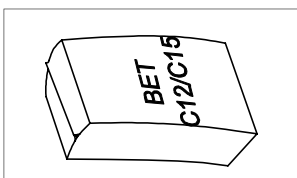
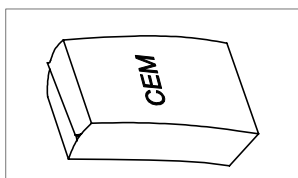
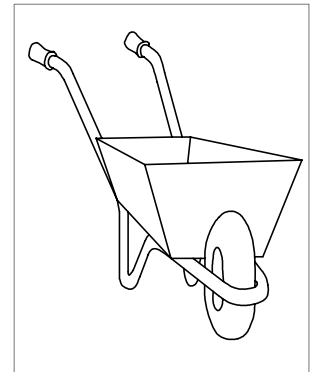
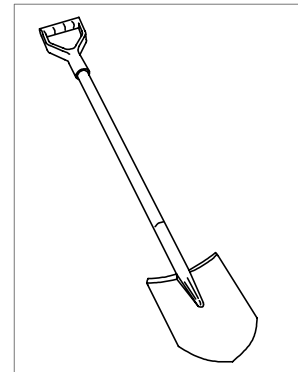
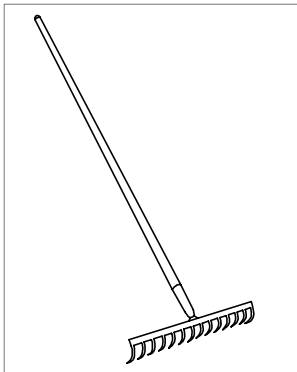
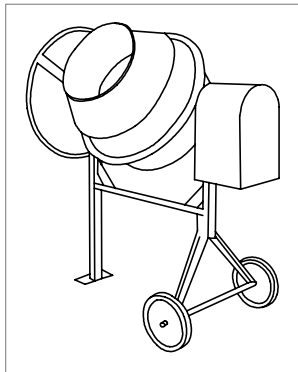
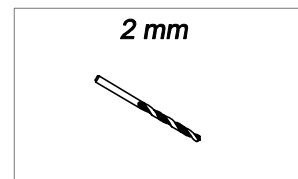
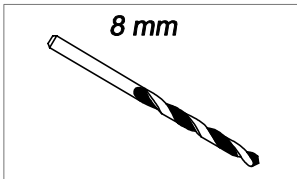
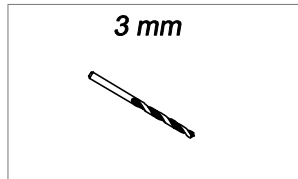
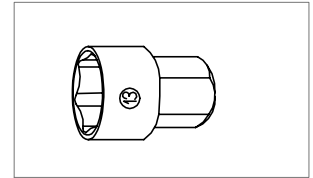
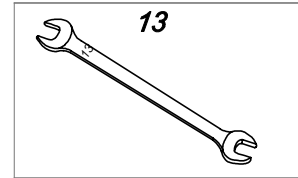
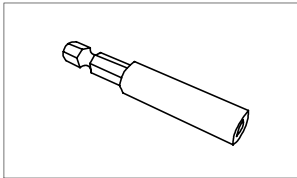
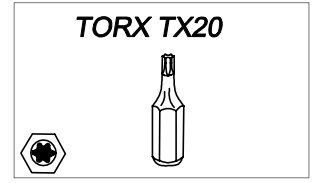
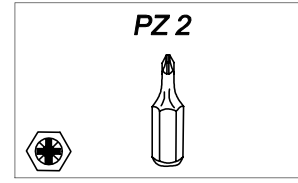
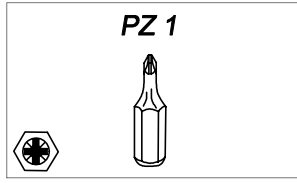
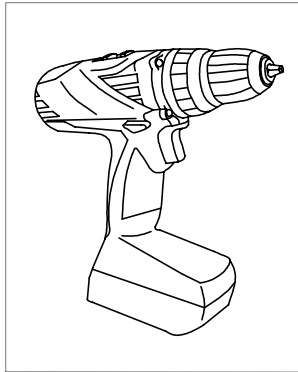
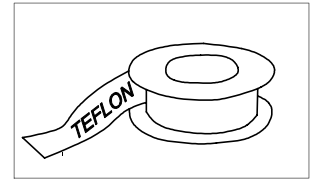
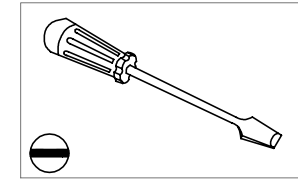
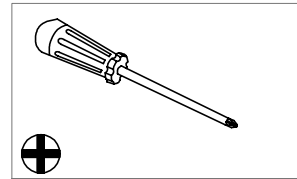
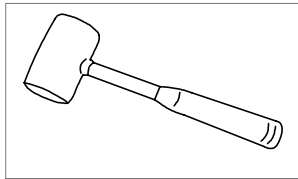
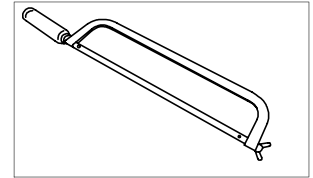
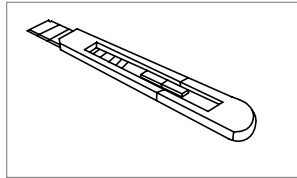
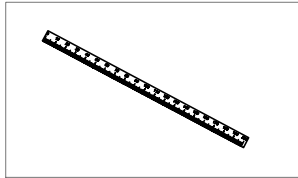
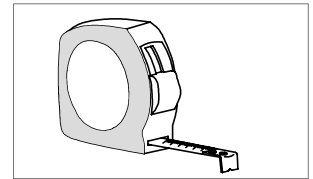
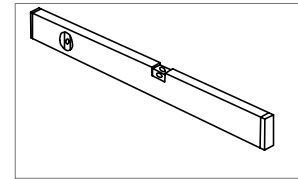
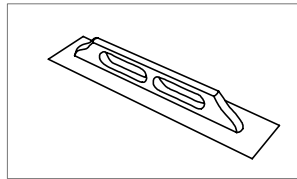
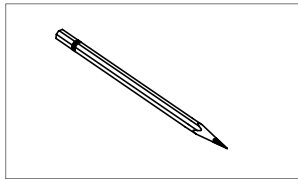

PL Podłoże

GB Ground

DE Untergrund

FR Terrain

NL Ondergrond



PL Struktura basenu wkopanego musi być zabezpieczona folią budowlaną.

FR La structure bois enterrée doit être protégée selon les instructions du manuel fourni.

GB Wooden structure if sunk in the ground must be protected in accordance with attached documentation.

DE Holzkonstruktionen, die in den Boden eingelassen sind, müssen gemäß der beigefügten Dokumentation geschützt werden.

NL Houten structuur moet indien verzonken in de grond worden beschermd volgens de bijgevoegde en voorgeschreven documentatie.

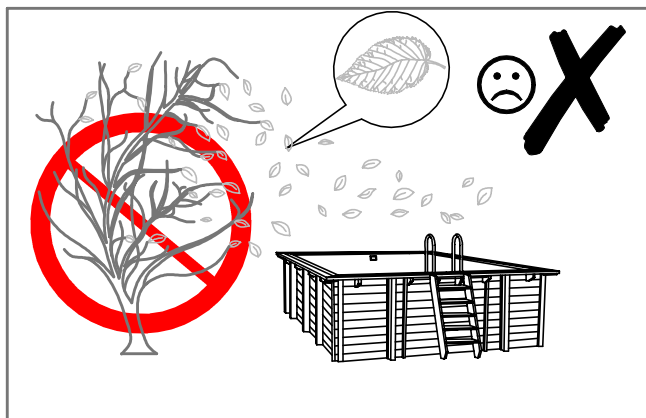
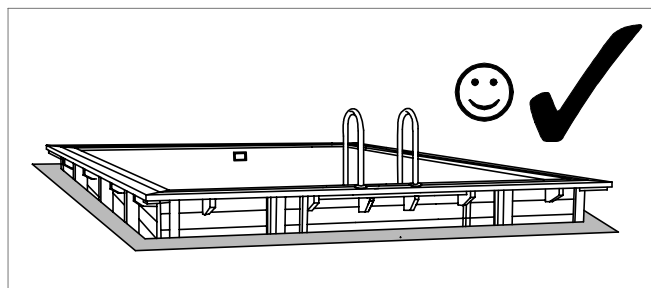
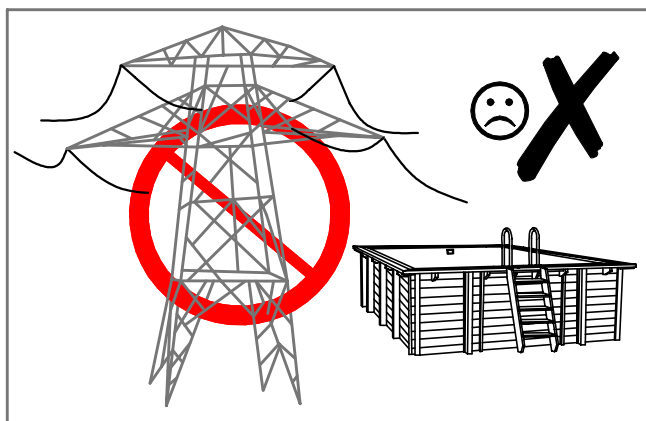
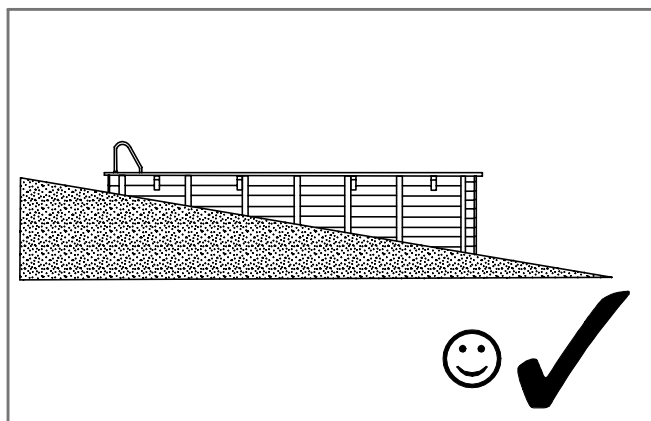
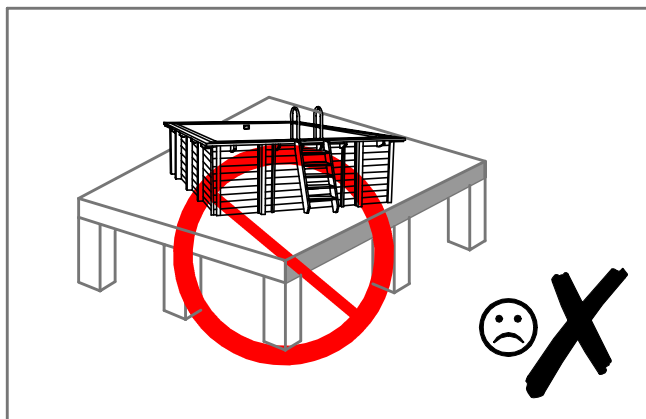
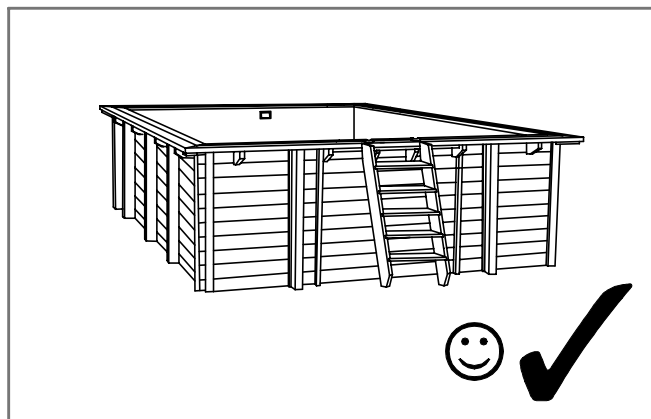

PL Struktura basenu w części lub w całości montowanego poniżej poziomu gruntu, musi być zabezpieczona w sposób zgodny z załączoną dodatkowo dokumentacją.

FR Il est exigé que la structure de la piscine enterrée ou semi-enterrée soit convenablement protégée selon les indices dans le document supplémentaire ci-joint.

GB Wooden structure if partly or completely sunk in the ground should be protected in accordance to the enclosed additional documentation.

DE Holzkonstruktionen, die teilweise oder vollständig in den Boden eingelassen sind, sollten gemäß den beigefügten zusätzlichen Unterlagen geschützt werden.

NL Houten constructies die gedeeltelijk of volledig zijn verzonken in de grond moeten worden beschermd volgens de bijgevoegde aanvullende documentatie.

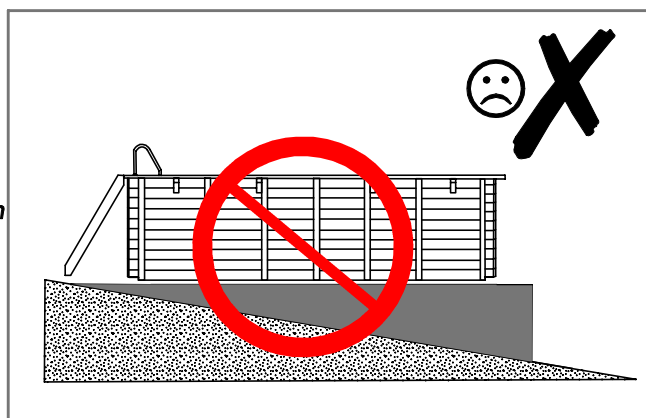

PL Podłoże

GB Ground

DE Untergrund

FR Terrain

NL Ondergrond



PL Wymagane zabezpieczenie struktury przy montażu basenu poniżej poziomu gruntu.

FR Un système de protection de la structure est exigé dans le cas où la piscine est installée en dessous du niveau du sol.

GB Wooden structure protection required in case of in-ground installation.

DE Erforderliches Schutz für Struktur eines Holzpool, wenn es unter der Boden montieren.

NL Bescherming van de houten constructie is absoluut noodzakelijk bij ingebouwde zwembaden.

- 1** FUNDAMENT BASENU / DALLE BETON / FOUNDATION / DAS FUNDAMENT / FUNDERING
- 2** RURA DRENARSKA / TUYAU DE DRAINAGE / DRAINAGE PIPE / DRÄNAGEROHR / DRAINAGE PIJP
- 3** PEČERZYKOWA FOLIA FUNDAMENTOWA / PROTECTION DE SOUBASSEMENT / FOUNDATION BUBBLE WRAP / NOPPENFOLIE / NOPPENFOLIE
- 4** ŻWIR / GRAVIER / GRAVEL / DER KIES / GRIND
- 5** GEOWŁÓKNINA OGRODOWA / GEOTEXTILE / GEOTEXTILE / GARTEN GEOTEXTILE / GEOTEXTEL
- 6** GRUNT / TERRAIN / GROUND / DER BODEN / BODEM

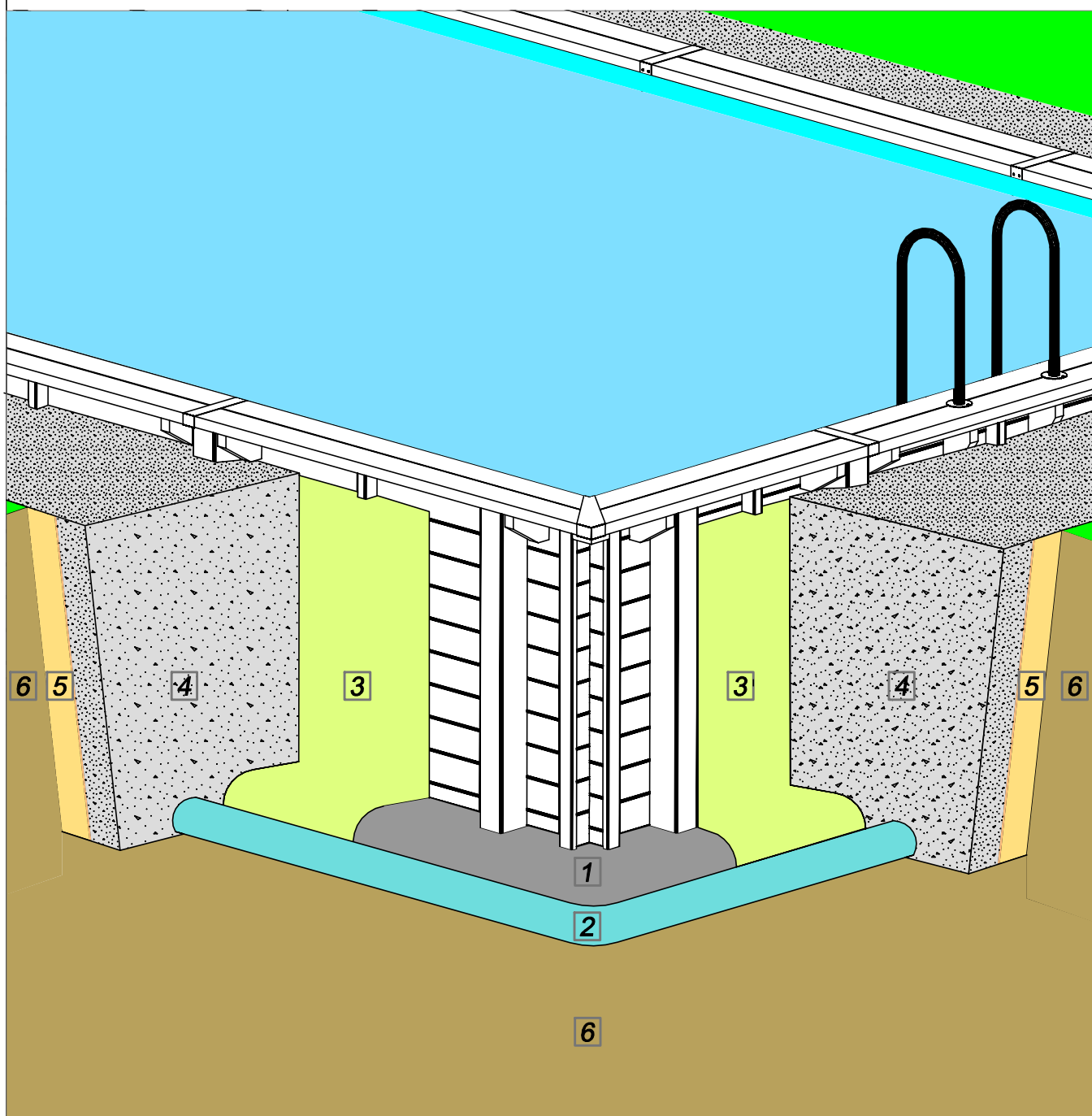

PL Podłoże

GB Ground

DE Untergrund

FR Terrain

NL Ondergrond



PL Schemat przygotowania wykopu / podłoża pod zbrojoną wylewkę betonową.

FR Schema de préparation de l'excavation / lit de sable pour la dalle en béton armé.

GB Scheme of preparation of excavation / ground for reinforced concrete screed.

DE Schema der Vorbereitung von Aushub / Boden für Stahlbeton Estrich.

NL Opzet voor de voorbereiding van uitgraving/zand voor dekvloeren van gewapend beton.

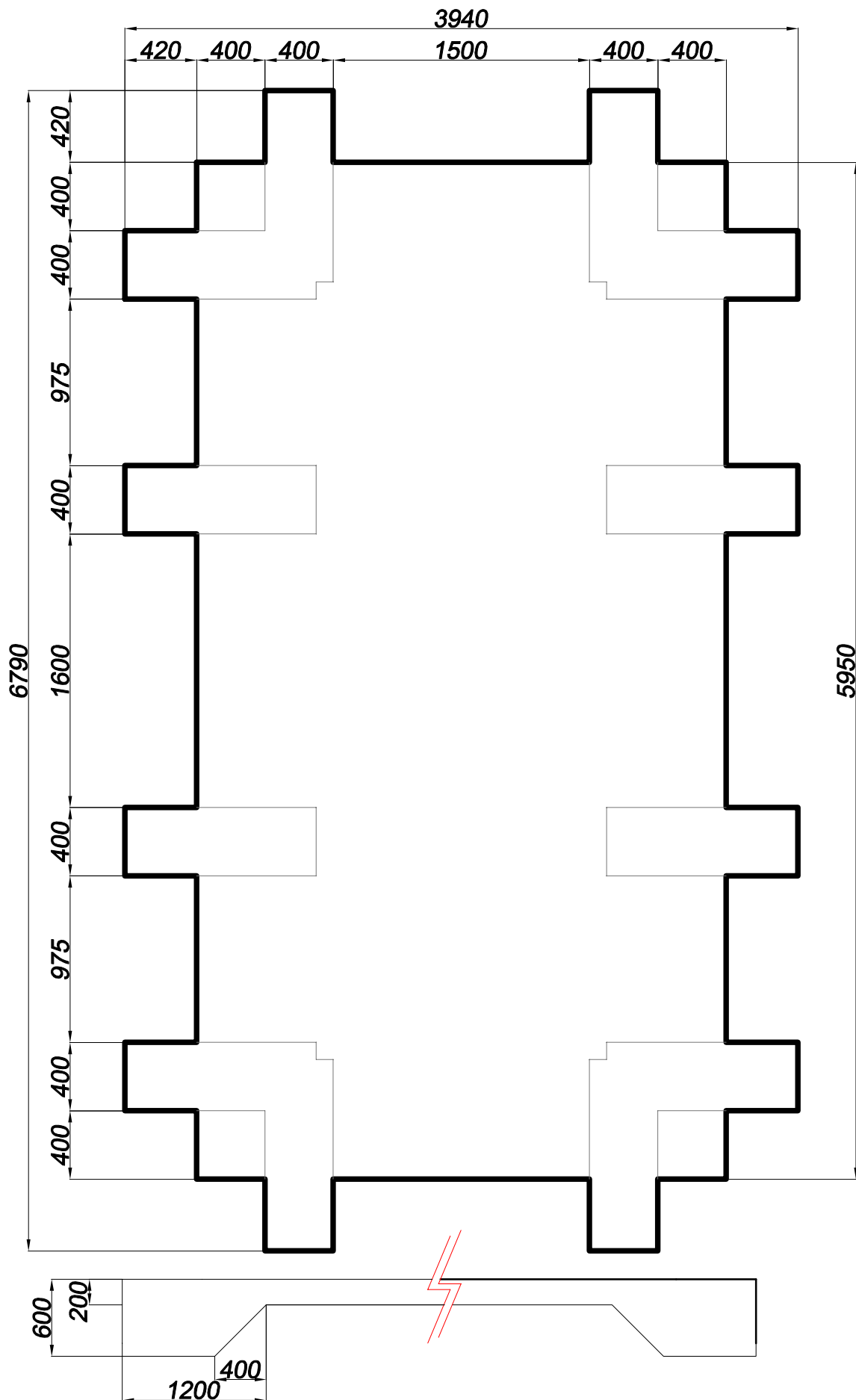

PL Podłoże

GB Ground

DE Untergrund

FR Terrain

NL Ondergrond



- PL** Powierzchnia musi być twarda, płaska i wypoziomowana. Zastosuj piasek stabilizowany cementem.
- FR** La sous-couche doit être parfaitement ferme, plate et de niveau. Utilisez le sable stabilisé au ciment.
- GB** The surface must be firm, flat and leveled. Use cement-stabilized sand.
- DE** Der Untergrund muss fest, flach und eben sein. Verwenden Sie zementstabilisierten Sand.
- NL** De ondergrond moet stevig, vlak en waterpas zijn. Gebruik gestabiliseerd zandcement.

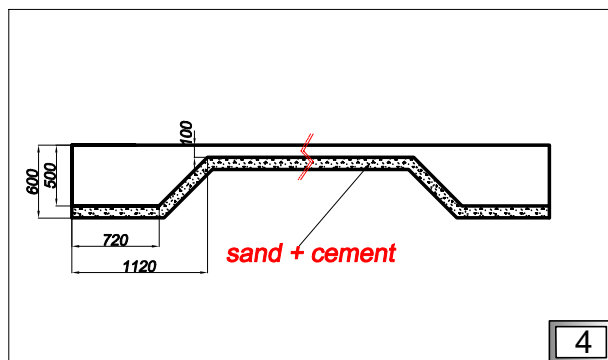
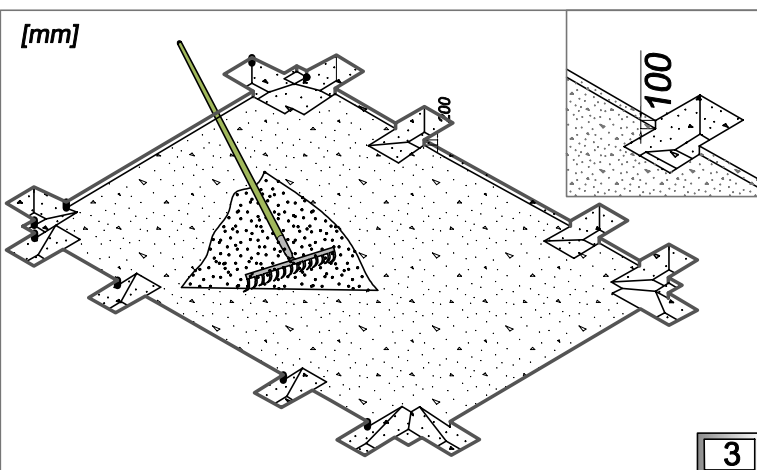
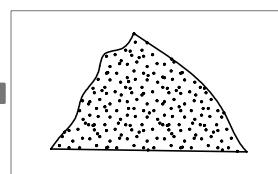
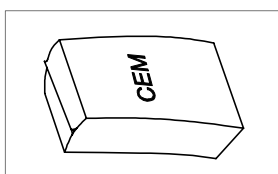
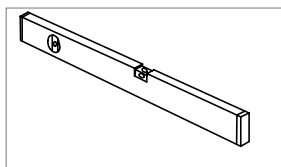
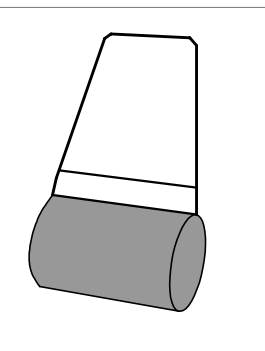
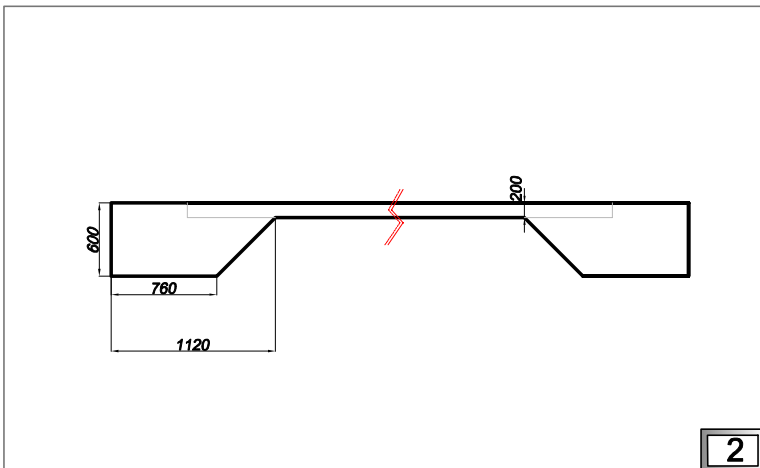
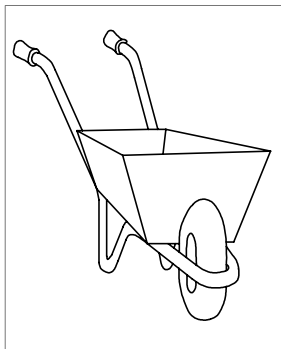
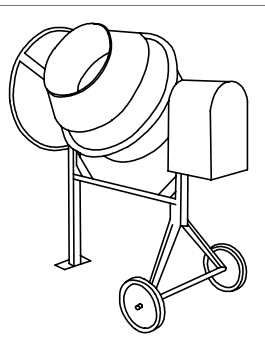
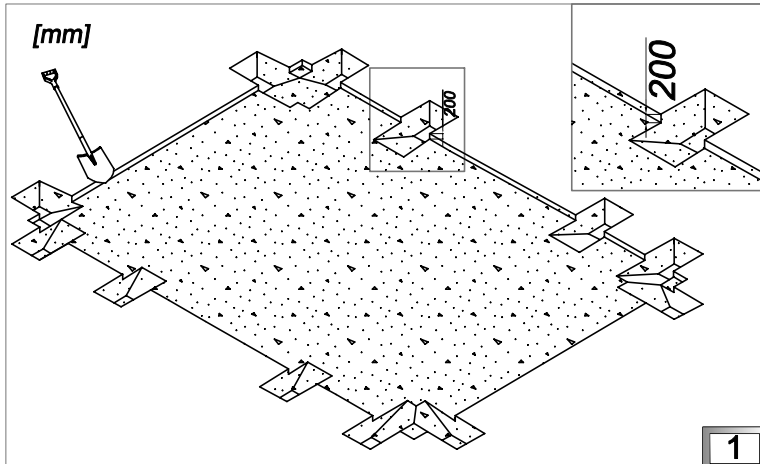
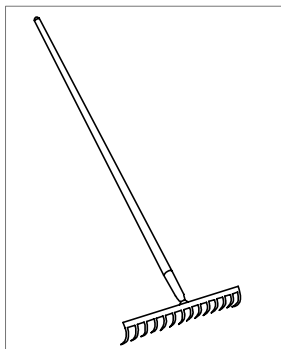
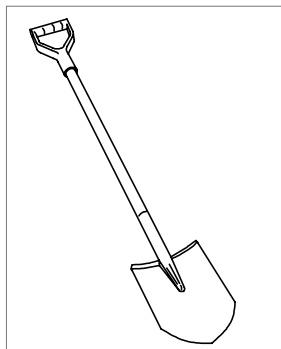

(PL) Podłoże

(GB) Ground

(DE) Untergrund

(FR) Terrain

(NL) Ondergrond



- (PL)** Schemat rozmieszczenia słupków 2T (I) oraz przygotowania zbrojenia pod wylewkę betonową.
- (FR)** Schema de positionnement des poteaux 2T (I) et préparation de l'armature pour la dalle en béton.
- (GB)** Scheme of steel bearers 2T (I) arrangement, preparing concrete base.
- (DE)** Schema der Stahlträger 2T (I) Anordnung, Vorbereitung der Betonbasis.
- (NL)** Opzet voor stalen dragers 2T (I) opstelling, voorbereiding van betonnen basis.

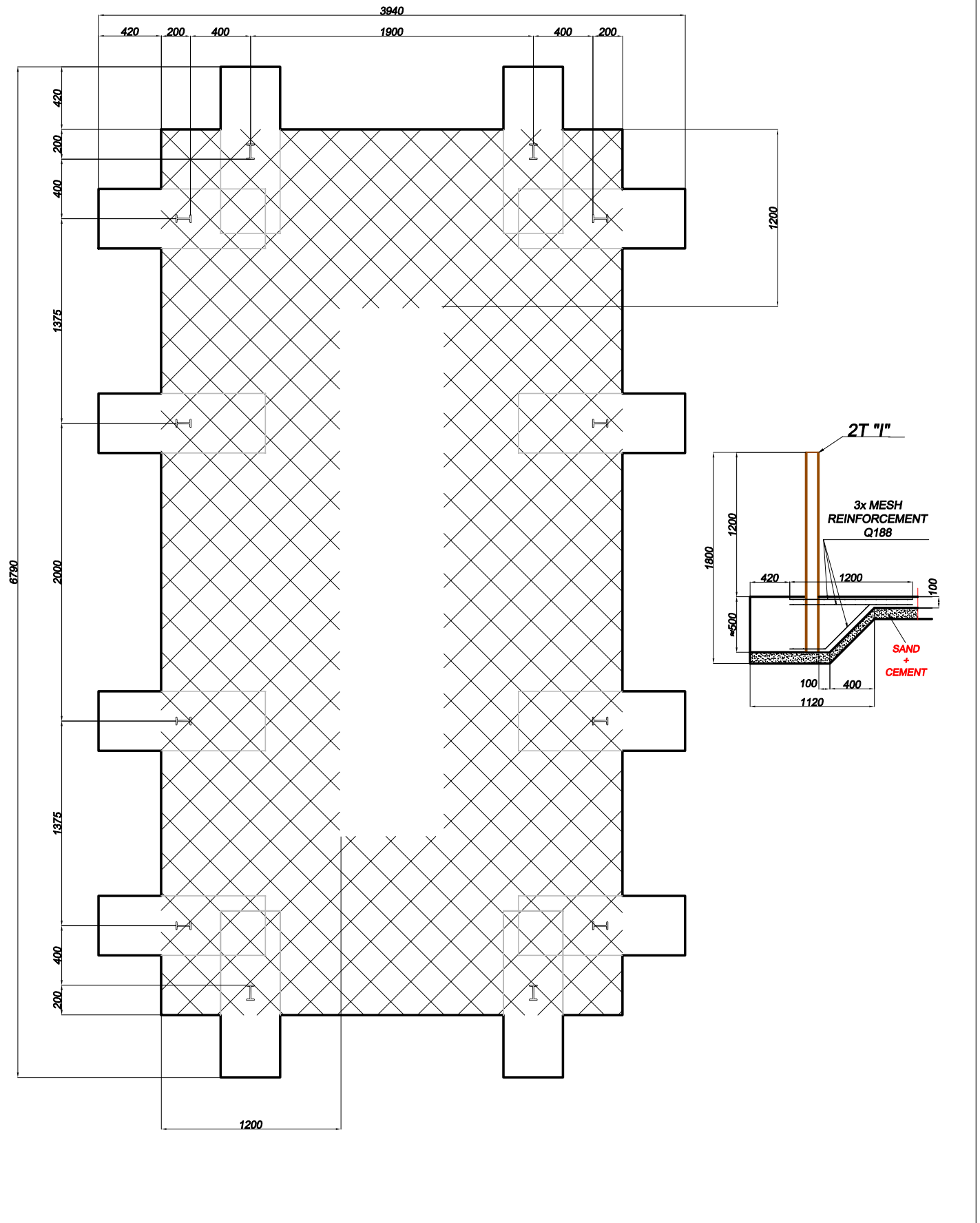

(PL) Podłoże

(GB) Ground

(DE) Untergrund

(FR) Terrain

(NL) Ondergrond



- (PL)** Powierzchnia musi być twarda, płaska i wypoziomowana. Pamiętaj o wykonaniu zbrojenia wylewki betonowej.
- (FR)** La sous-couche doit être parfaitement ferme, plate et de niveau. Préparez l'amature de la dalle en béton.
- (GB)** The surface must be firm, flat and leveled. Remember about reinforcement of concrete screed.
- (DE)** Der Untergrund muss fest, flach und eben sein. Denken Sie an die Verstärkung des Betonestrichs.
- (NL)** De ondergrond moet stevig, vlak en waterpas zijn. Denk aan de versterking van de dekvloer van beton.

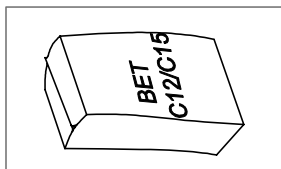

A-IIIN (B500SP) Q188

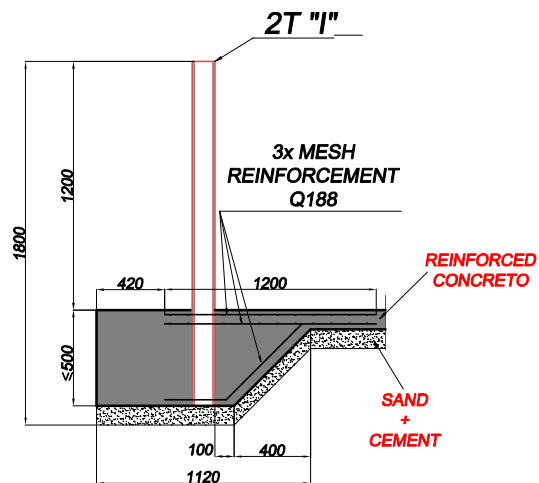
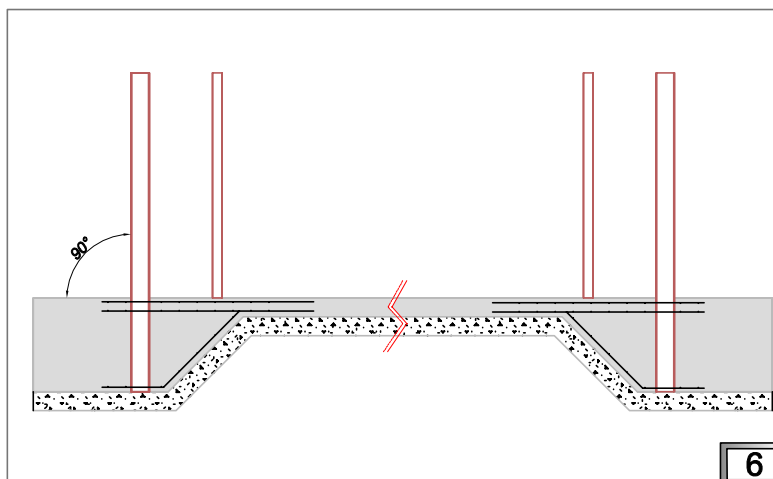
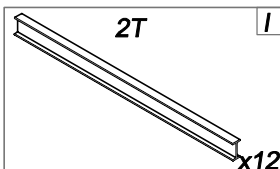
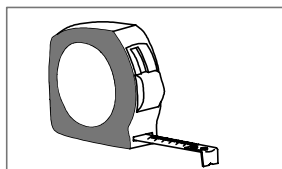
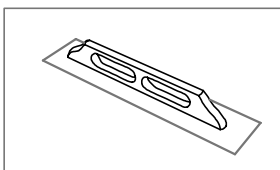
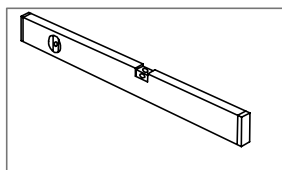
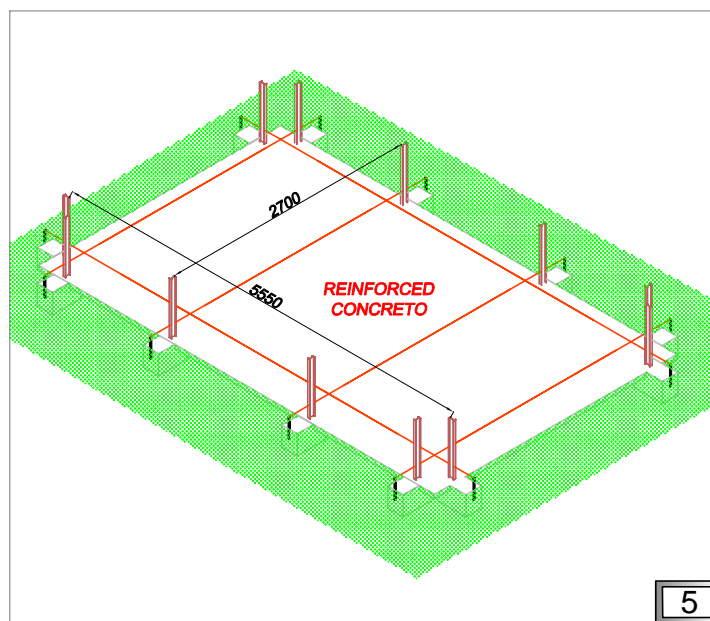
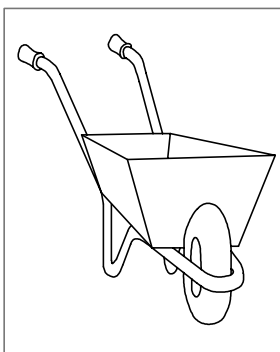
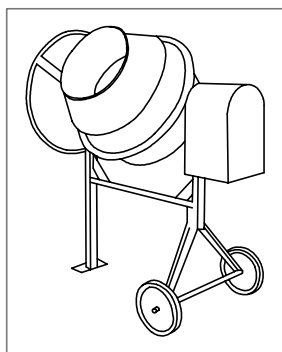
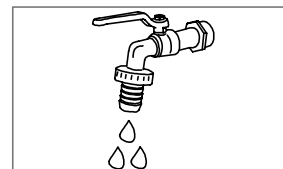
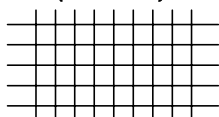

PL Podłoże

GB Ground

DE Untergrund

FR Terrain

NL Ondergrond



- PL** Schemat rozmieszczenia słupków 2T (I) oraz przygotowania wylewki betonowej.
- FR** Schéma de disposition des pteaux métalliques 2T (I) et de préparation de la dalle en béton.
- GB** Scheme of steel bearers 2T (I) arrangement, preparing concrete base.
- DE** Schema der Stahlträger 2T (I) -Anordnung, Vorbereitung der Betonbasis.
- NL** Opzet voor stalen dragers 2T (I) opstelling, voorbereiding van betonnen basis.

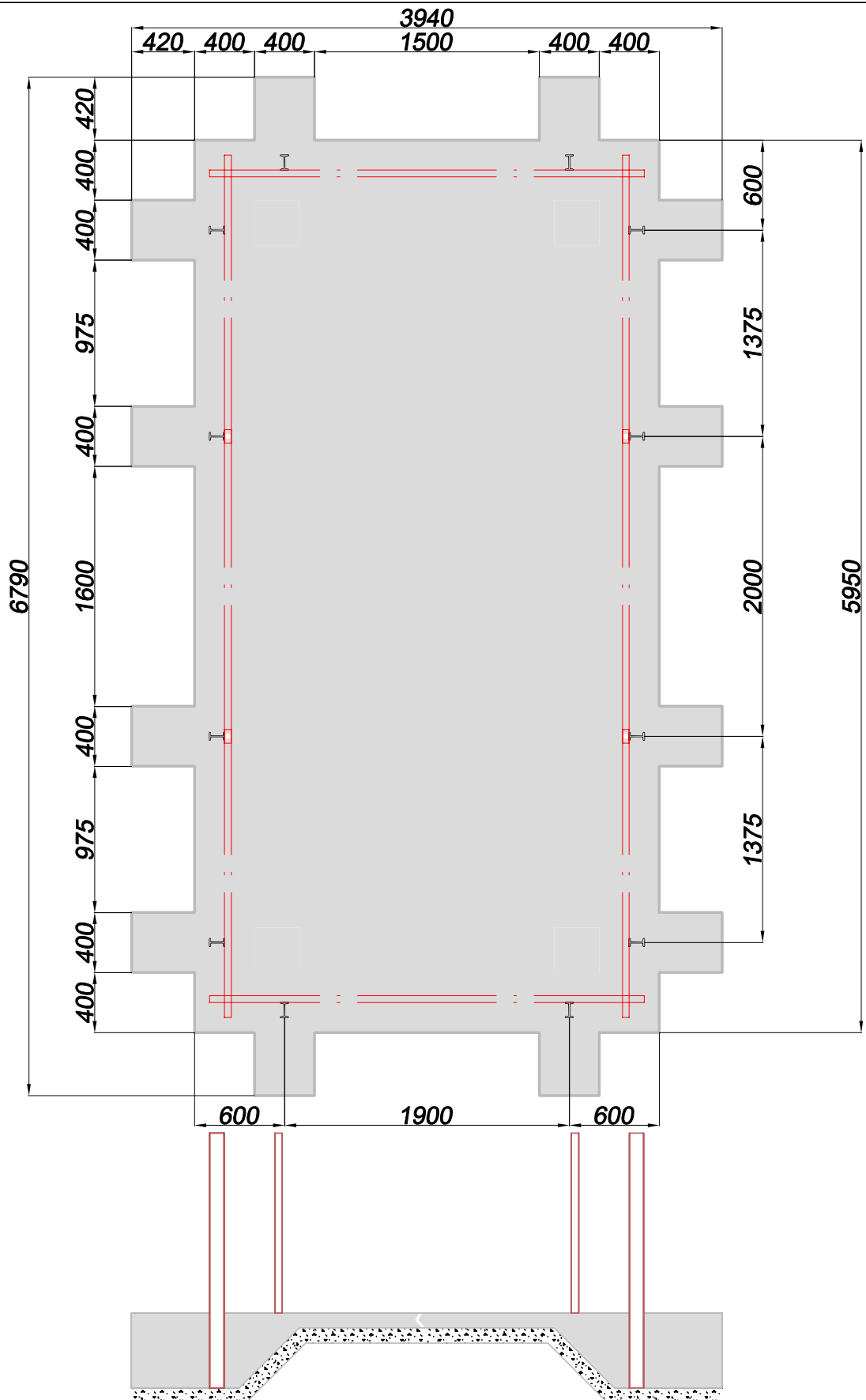

PL Struktura drewniana

GB Wooden structure

DE Holzstruktur

FR La structure bois

NL Houten structuur



PL Schemat rozmieszczenia warstw struktury. Ułożenie warstwy I.

FR Schéma de disposition des couches de la structure. Pose de la couche I.

GB Arrangement of structure's layers. Putting layer I.

DE Anordnung der Schichten der Struktur. Auflegen der I-Schichte.

NL Opbouw van de structuurlagen.

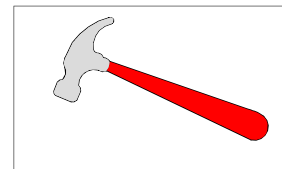
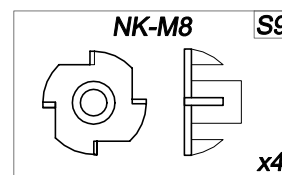
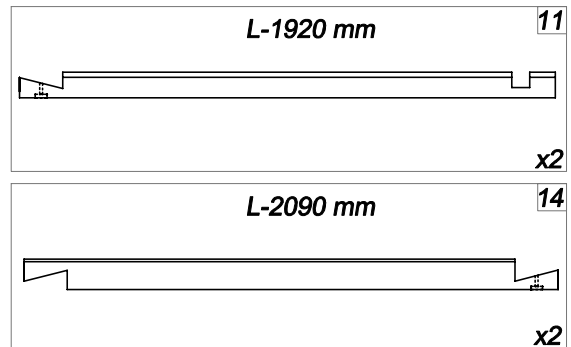
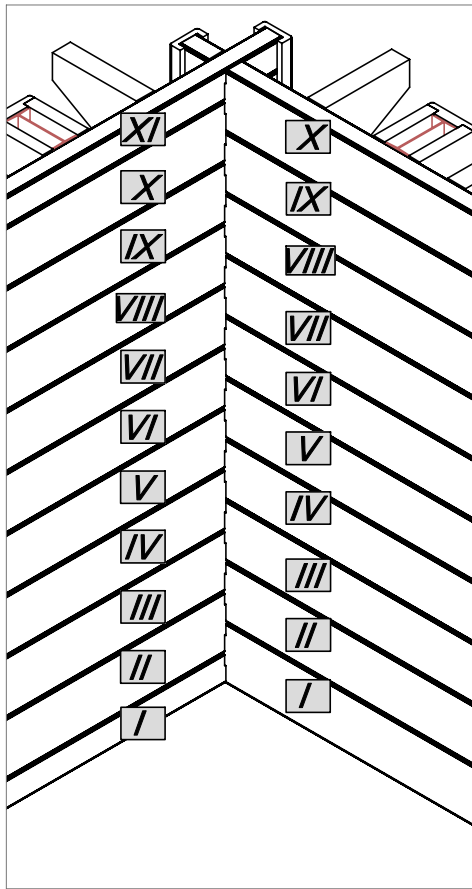

11 14

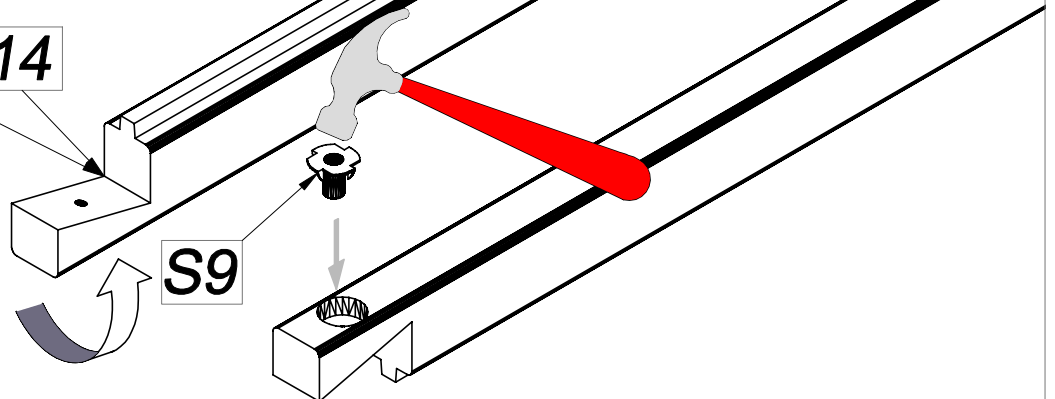

PL Struktura drewniana

GB Wooden structure

DE Holzstruktur

FR La structure bois

NL Houten structuur



- PL** Ułożenie warstwy I.
- FR** Pose de la couche I.
- GB** Putting layer I.
- DE** Auflegen der I-Schichte.
- NL** Opbouw van de structuurlagen.

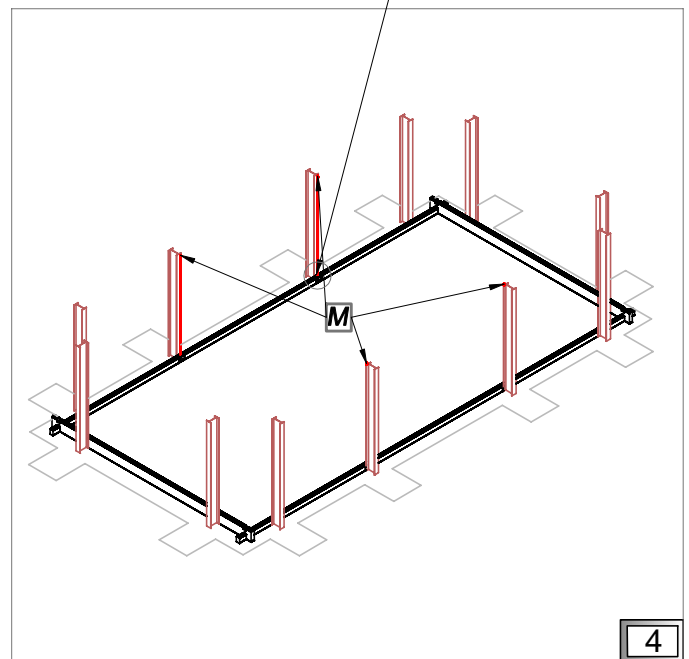
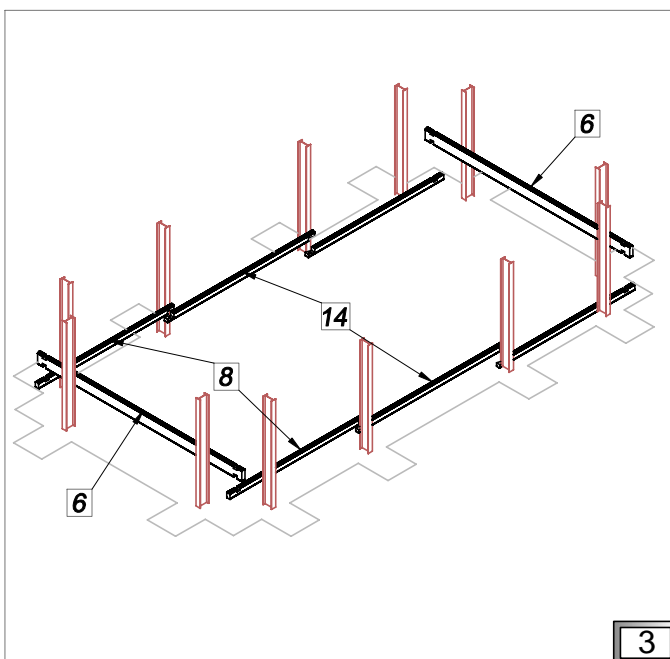
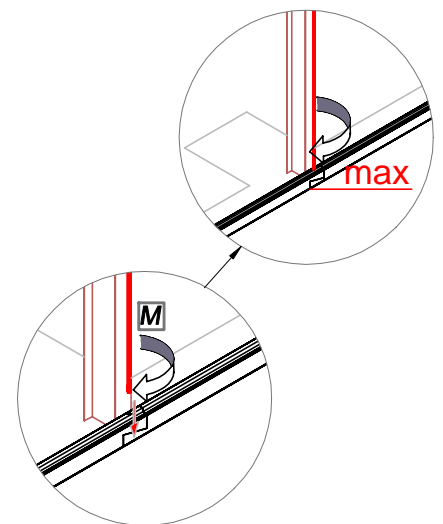
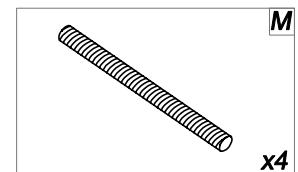
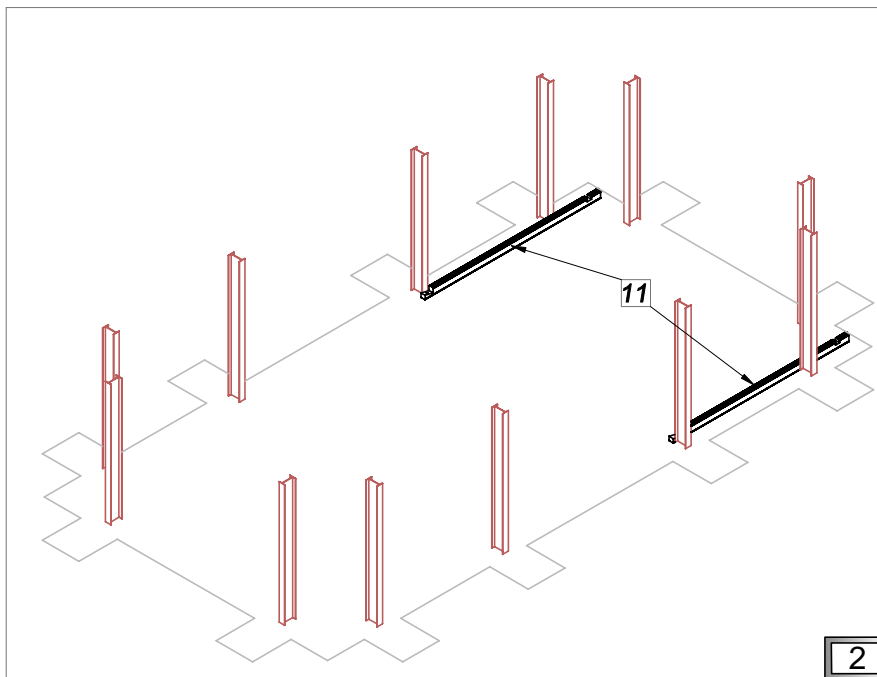
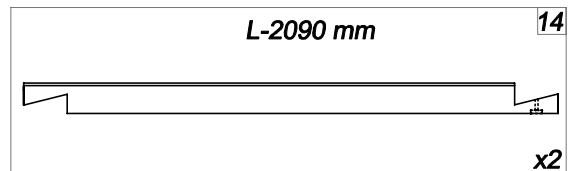
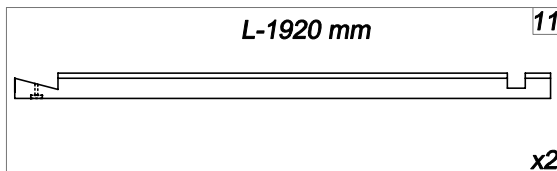
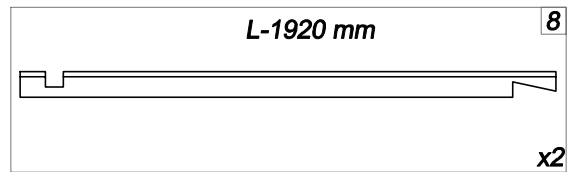
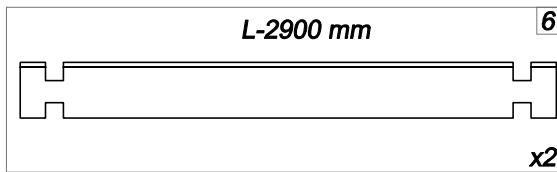

PL *Struktura drewniana*

GB *Wooden structure*

DE *Holzstruktur*

FR *La structure bois*

NL *Houten structuur*



PL Po ułożeniu każdej z warstw sprawdź przekątne według rysunku.

FR Vérifiez après la pose de chaque couche que les diagonales soient bien conformes au dessin technique.

GB After putting each layer check diagonals according to the drawing.

DE Nachdem Sie jede Schicht angeordnet haben, überprüfen Sie die Diagonalen gemäß der Zeichnung.

NL Controleer na het aanbrengen van elke laag de diagonalen volgens de tekening.

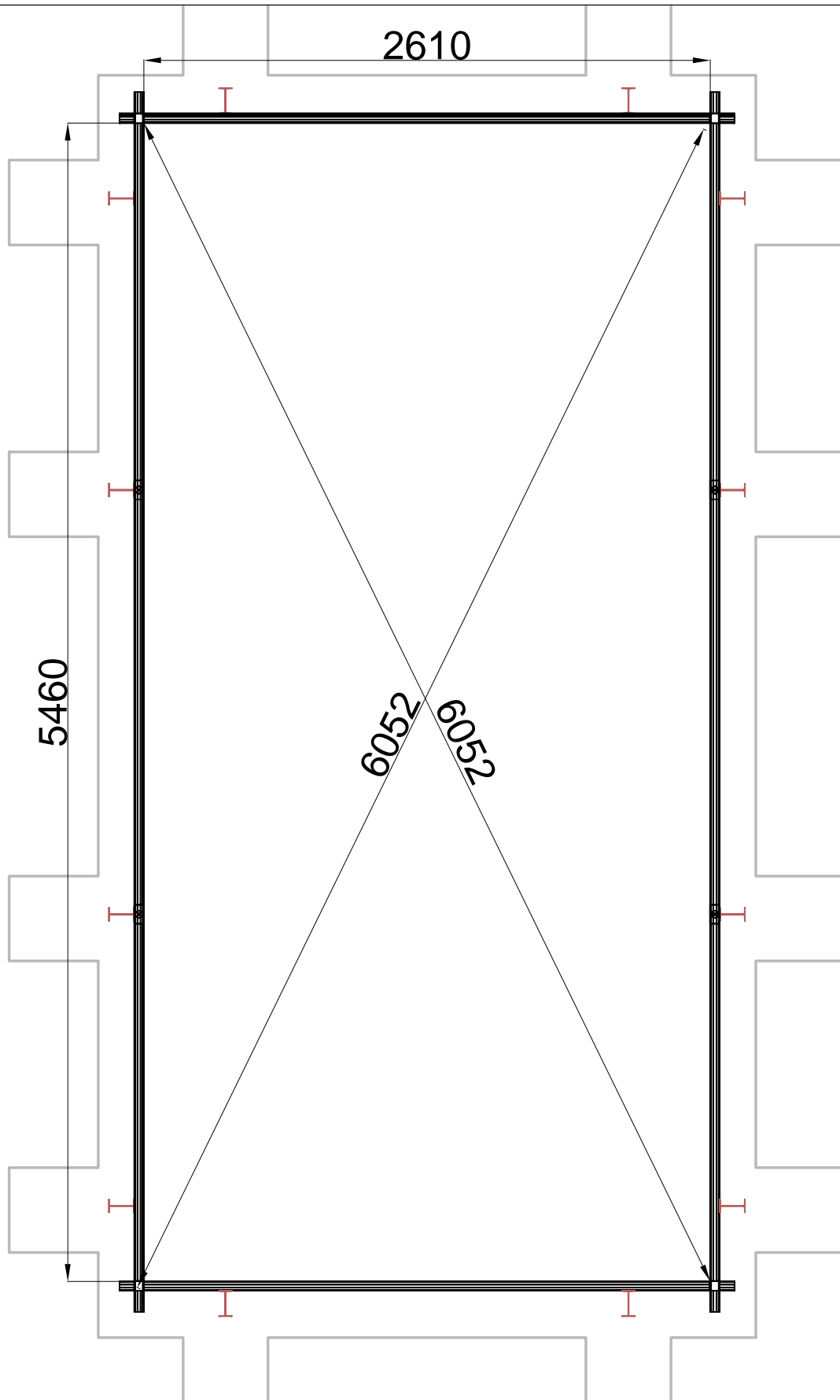

PL *Struktura drewniana*

GB *Wooden structure*

DE *Holzstruktur*

FR *La structure bois*

NL *Houten structuur*



PL Ułożenie kolejnych warstw. Sprawdź przekątną po każdej ułożonej warstwie.

FR L'assemblage des couches suivantes. Vérifiez la conformité des diagonales après la pose de chaque couche.

GB Arrangement of layers. Check diagonals after having arranged each layer.

DE Anordnung der Schichten. Überprüfen Sie die Diagonalen nachdem Sie jede Schichte angeordnet haben.

NL Opbouw van de lagen. Controleer de diagonalen na het aanbrengen van elke laag.

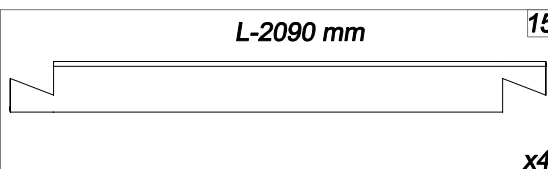
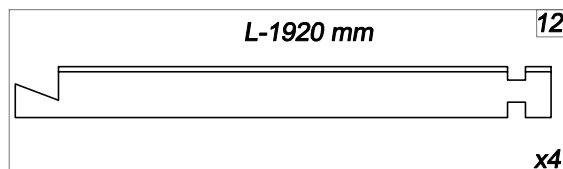
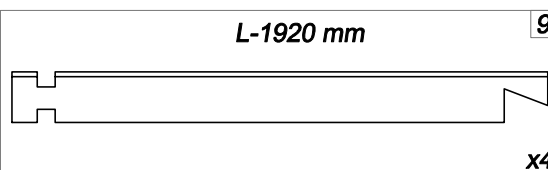
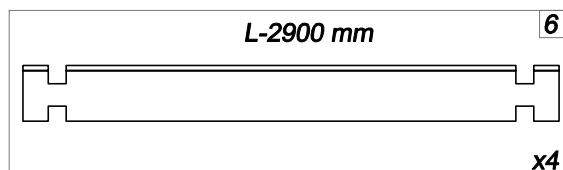

II-III

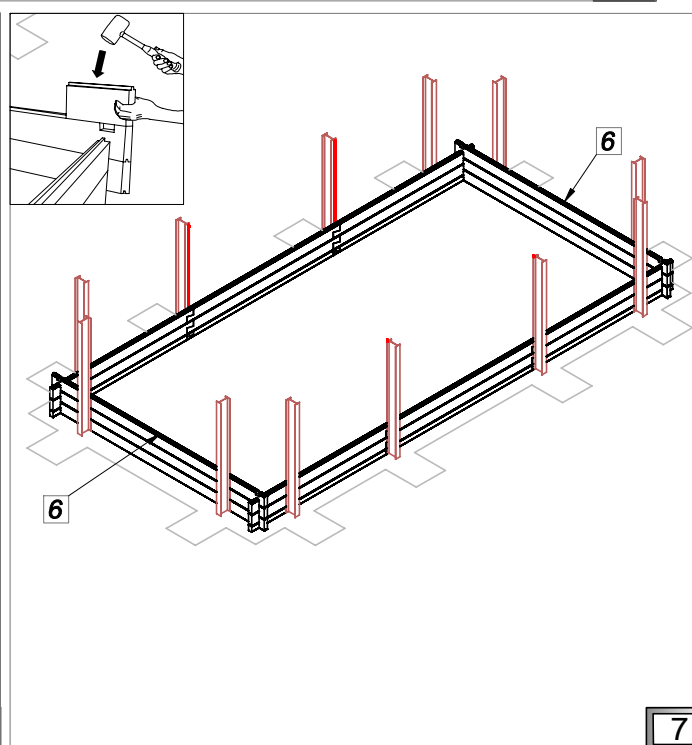
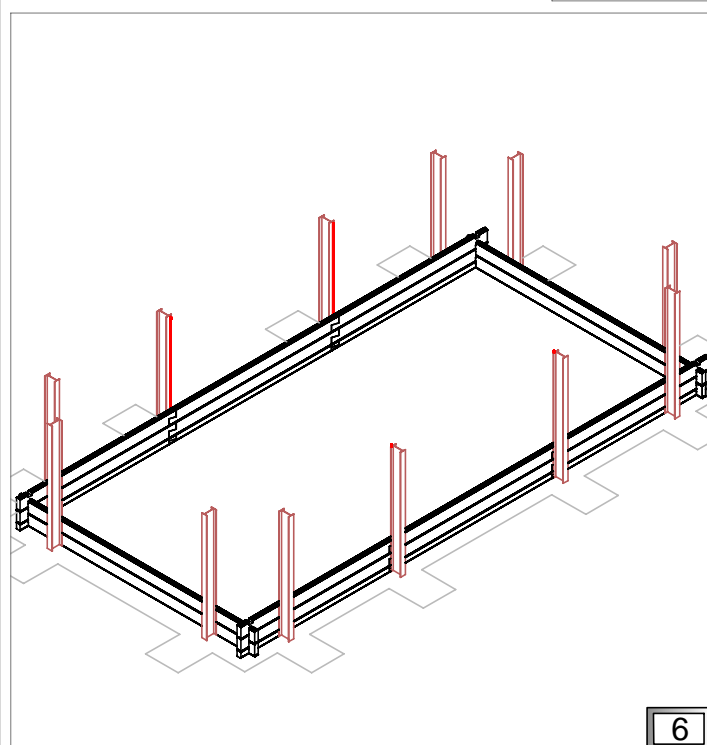
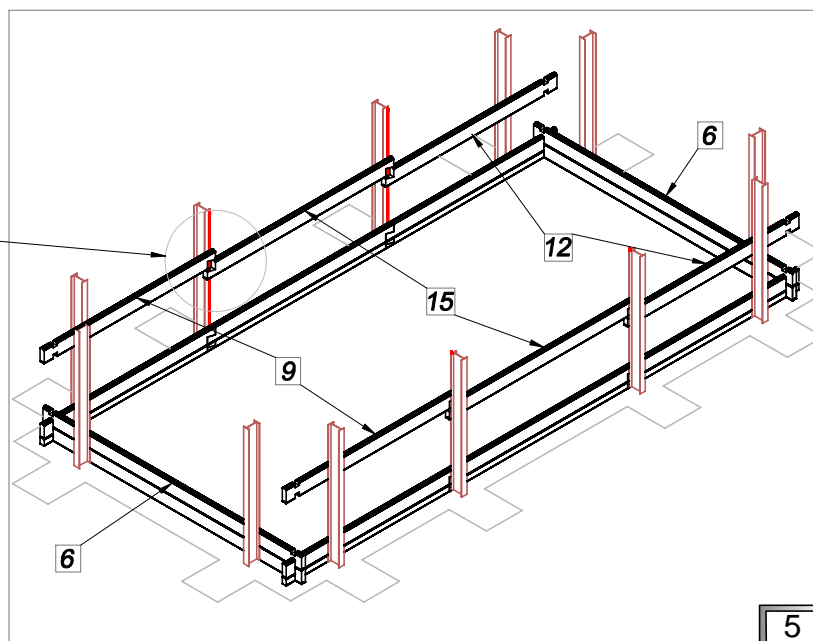
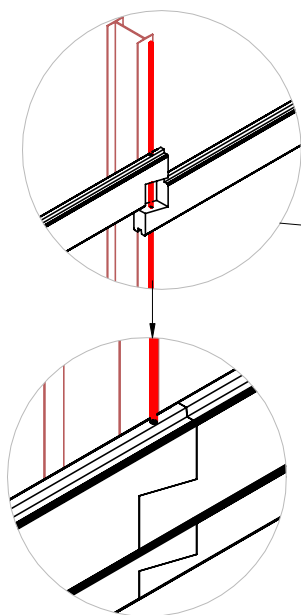

(PL) *Struktura drewniana*

(GB) *Wooden structure*

(DE) *Holzstruktur*

(FR) *La structure bois*

(NL) *Houten structuur*



- (PL)** Ułożenie kolejnych warstw. Sprawdź przekątną po każdej ułożonej warstwie.
- (FR)** L'assemblage des couches suivantes. Vérifiez la conformité des diagonales après la pose de chaque couche.
- (GB)** Arrangement of layers. Check diagonals after having arranged each layer.
- (DE)** Anordnung der Schichten. Überprüfen Sie die Diagonalen nachdem Sie jede Schicht angeordnet haben.
- (NL)** Opbouw van de lagen. Controleer de diagonalen na het aanbrengen van elke laag.

L-2900 mm

6

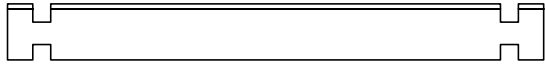

x1

L-1920 mm

9

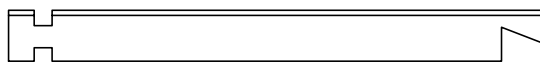

x2

L-1920 mm

12

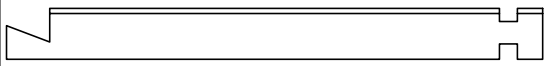

x2

L-2090 mm

15

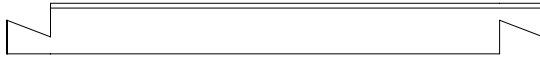

x2

L-2900 mm

4

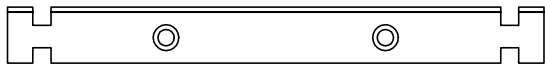

x1

IV

(NL) Installeer balk nummer 4 alleen op laag 4 in gebieden waar de temperatuur niet onder nul komt, is dit wel het geval plaats dan balk nummer 4 drie lagen hoger (risico op bevroering)

(DE) Installieren Sie die Nr. 4 auf der Schicht 4 ,wo fällt die Temperatur unten 0 ° C. Anderenfalls Teil Nr. 4 installieren Schicht oben . (Risiko ganz gefroren.)

(GB) Install the beam no 4 on the 4th layer. If pool installed in area where temperatures fall below 0°C , install the beam no 4 on higher layer.

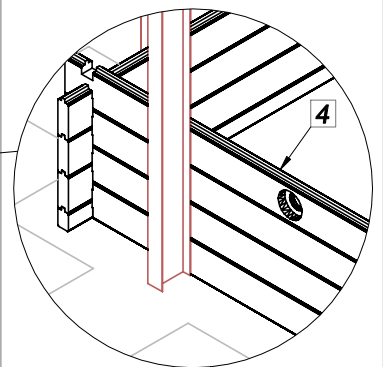
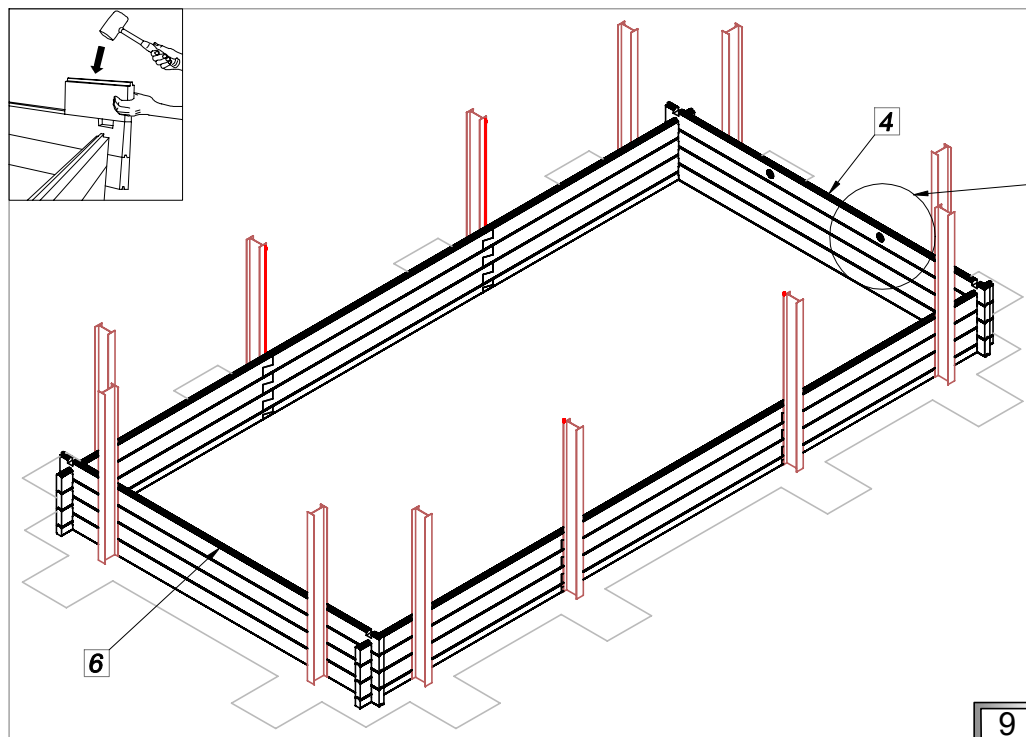
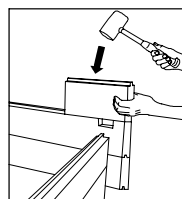
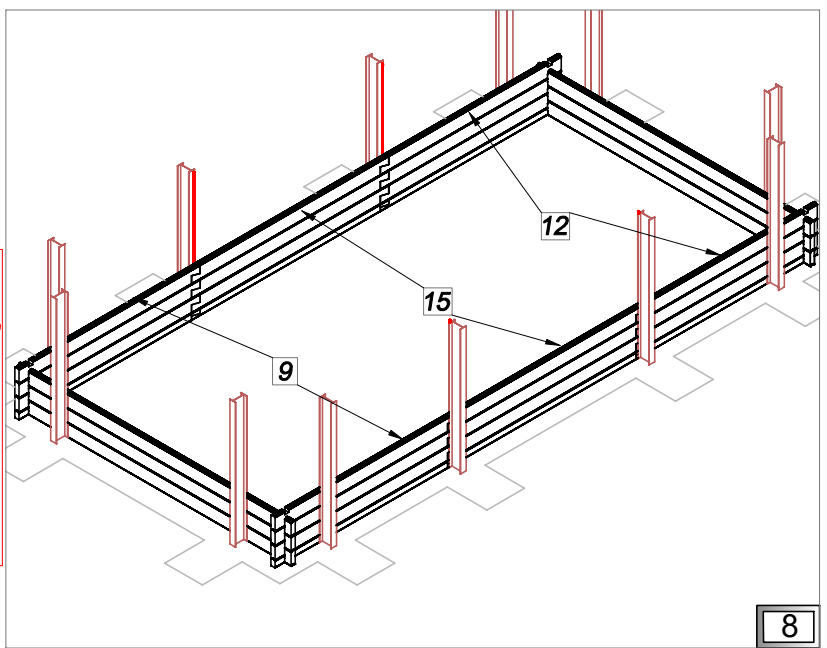

PL *Struktura drewniana*

GB *Wooden structure*

DE *Holzstruktur*

FR *La structure bois*

NL *Houten structuur*



- PL** Ułożenie kolejnych warstw. Sprawdź przekątną po każdej ułożonej warstwie.
- FR** L'assemblage des couches suivantes. Vérifiez la conformité des diagonales après la pose de chaque couche.
- GB** Arrangement of layers. Check diagonals after having arranged each layer.
- DE** Anordnung der Schichten. Überprüfen Sie die Diagonalen nachdem Sie jede Schicht angeordnet haben.
- NL** Opbouw van de lagen. Controleer de diagonalen na het aanbrengen van elke laag.

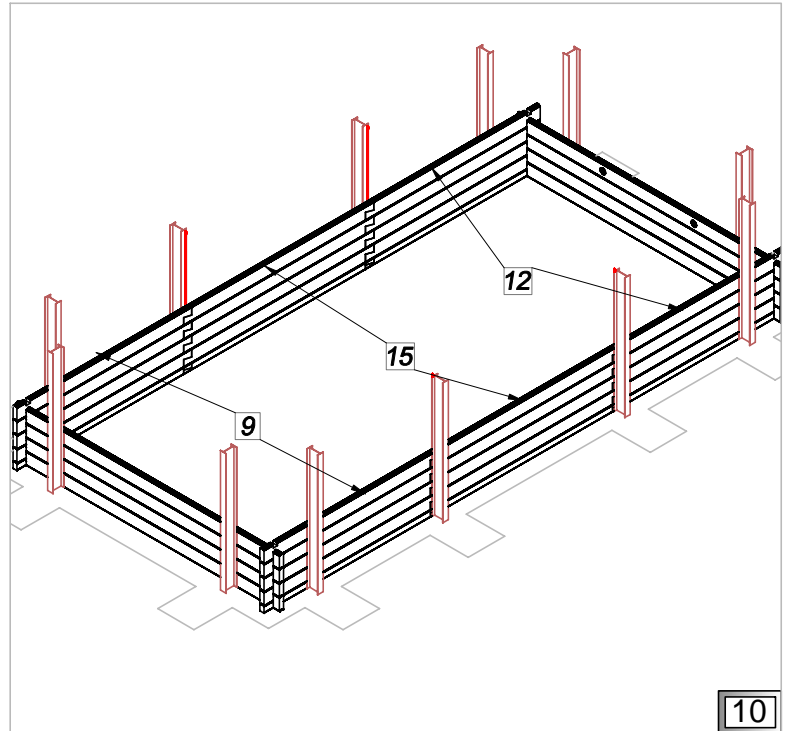
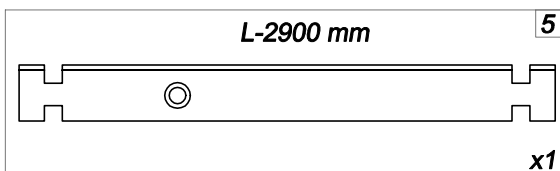
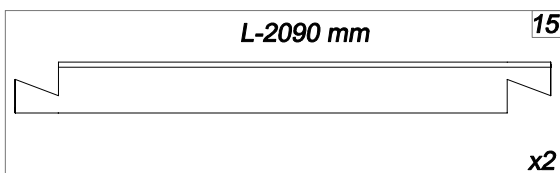
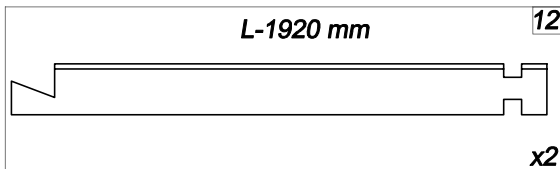
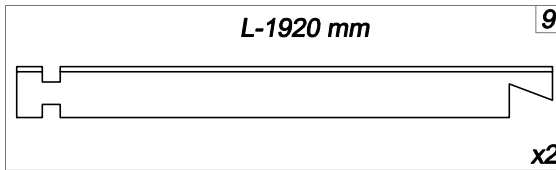
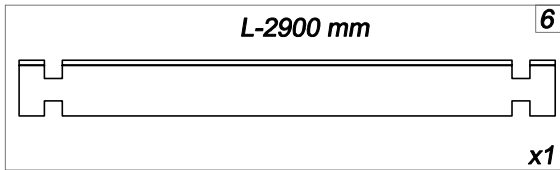

- PL** Proponowany układ deski z otworem na lampę, zalecane w przedziale 450 - 700 mm poniżej lustra wody
- FR** Emplacement suggéré, placez l'anneau derrière la lampe et montez-le à 450-700 mm sous la surface de l'eau
- GB** Proposed arrangement of board with a hole for lamp, recommended between 450-700 mm below the water surface.
- DE** Vorgeschlagene Platzierung; Platzieren Sie den Ring hinter der Lampe und montieren Sie ihn 450-700 mm unter der Wasseroberfläche.
- DE** Voorgestelde plaatsing; plaats de ring achter de lamp en monteer het geheel 450-700 mm onder het wateroppvlak.

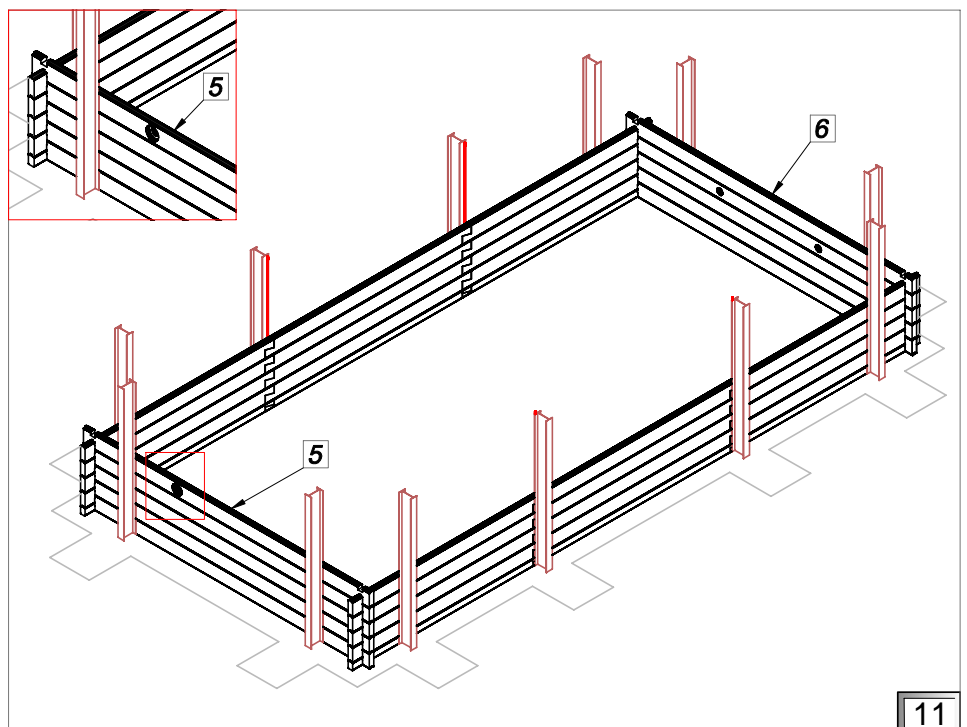
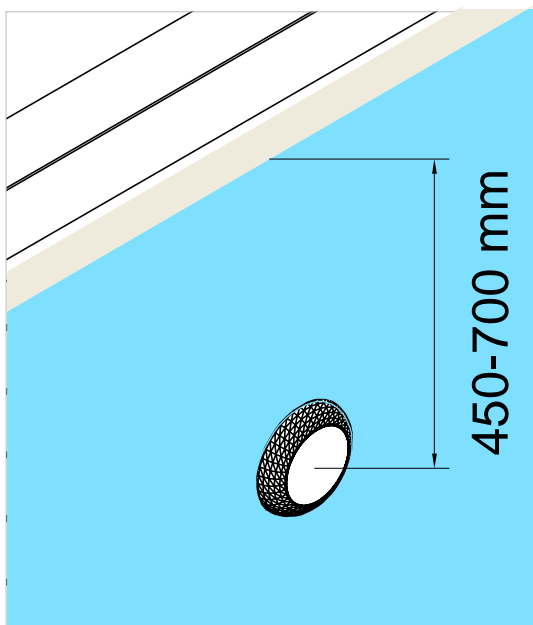

V

10

11

PL *Struktura drewniana*

GB *Wooden structure*

DE *Holzstruktur*

FR *La structure bois*

NL *Houten structuur*



PL Ułożenie kolejnych warstw. Sprawdź przekątną po każdej ułożonej warstwie.

FR L'assemblage des couches suivantes. Vérifiez la conformité des diagonales après la pose de chaque couche.

GB Arrangement of layers. Check diagonals after having arranged each layer.

DE Anordnung der Schichten. Überprüfen Sie die Diagonalen nachdem Sie jede Schichte angeordnet haben.

NL Opbouw van de lagen. Controleer de diagonalen na het aanbrengen van elke laag.

VI-VIII

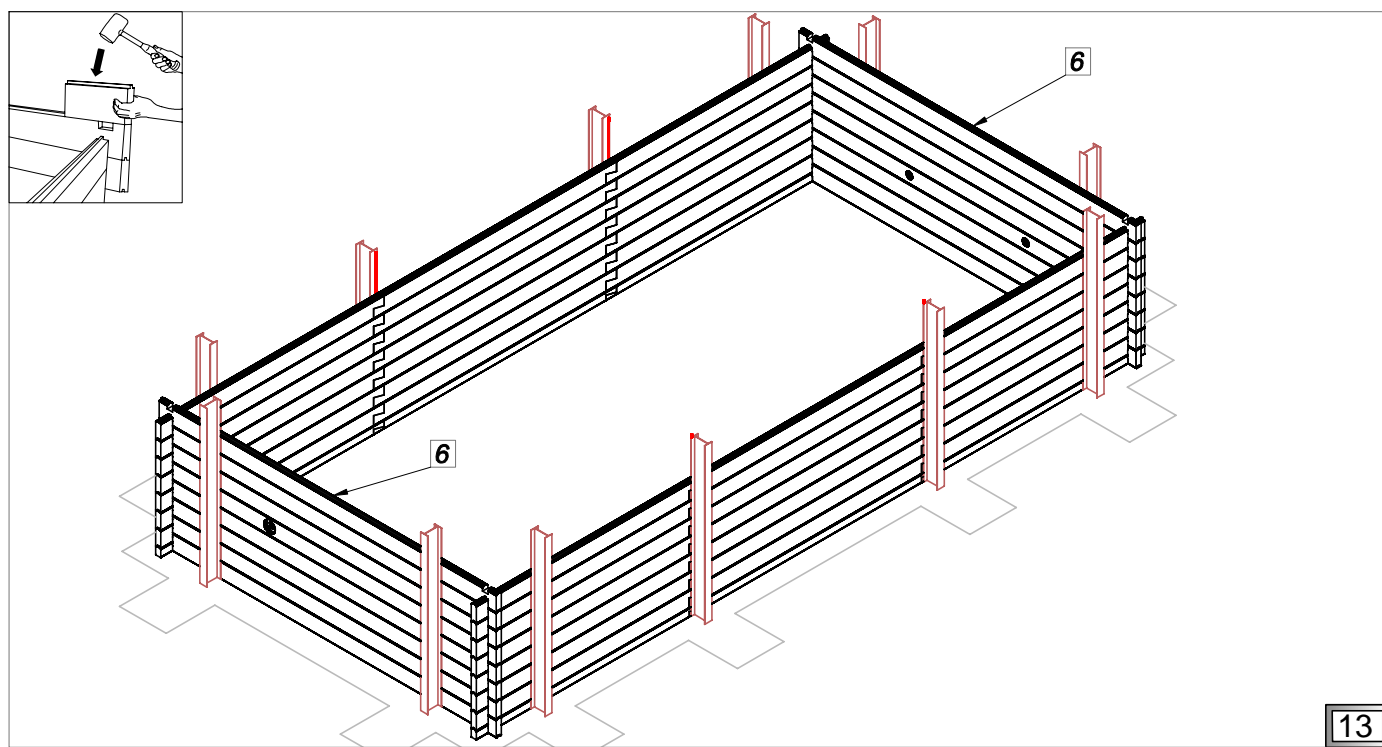
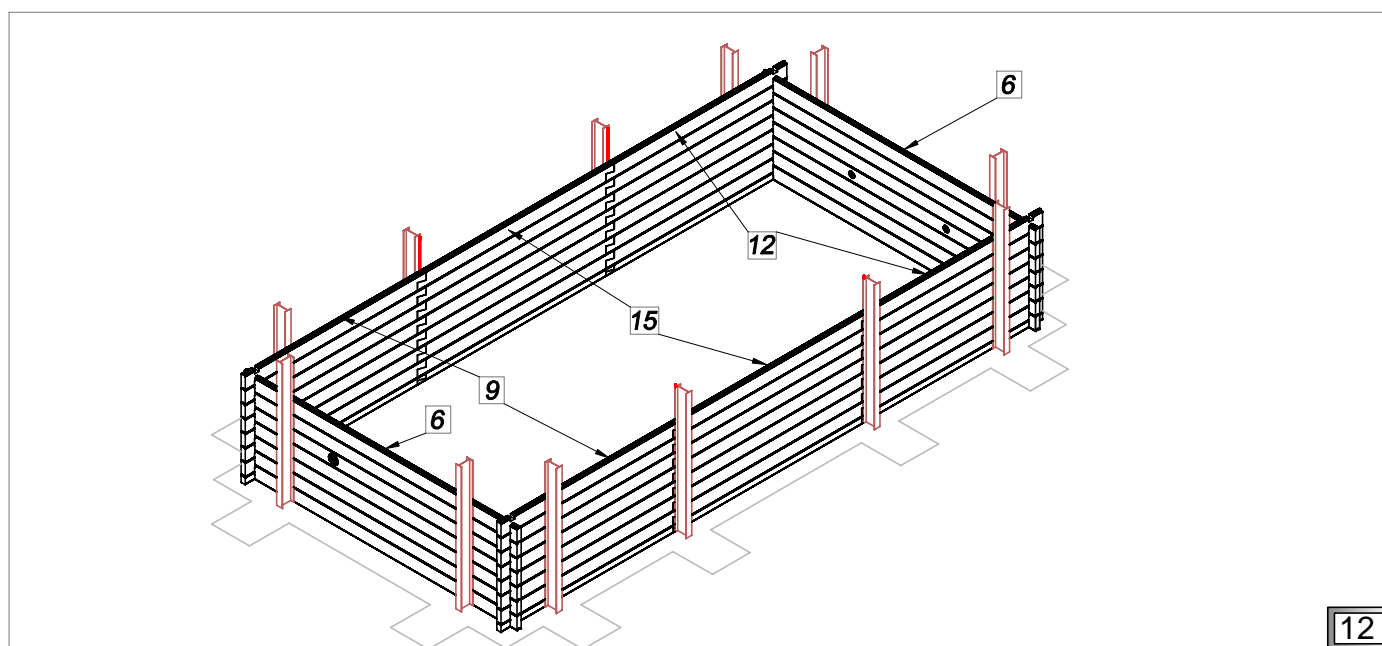
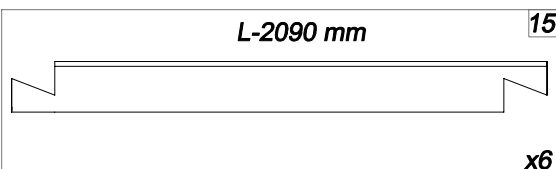
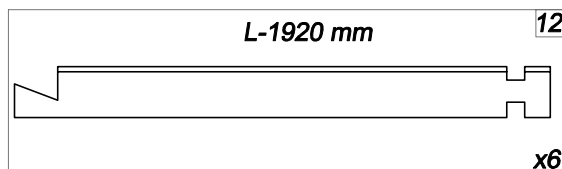
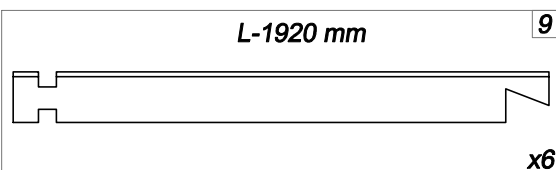
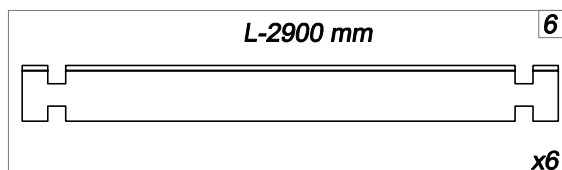

PL *Struktura drewniana*

GB *Wooden structure*

DE *Holzstruktur*

FR *La structure bois*

NL *Houten structuur*



PL Ułożenie kolejnych warstw. Sprawdź przekątną po każdej ułożonej warstwie.

FR L'assemblage des couches suivantes. Vérifiez la conformité des diagonales après la pose de chaque couche.

GB Arrangement of layers. Check diagonals after having arranged each layer.

DE Anordnung der Schichten. Überprüfen Sie die Diagonalen nachdem Sie jede Schicht angeordnet haben.

NL Opbouw van de lagen. Controleer de diagonalen na het aanbrengen van elke laag.

L-2900 mm

6

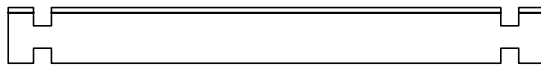

x1

L-1920 mm

9

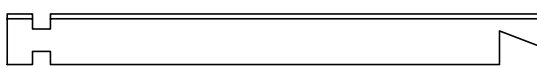

x2

L-1920 mm

12

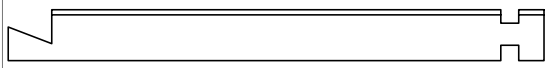

x2

L-2090 mm

15

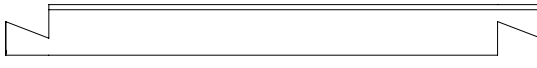

x2

L-2900 mm

3

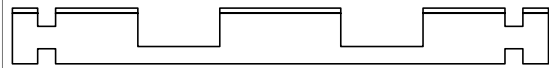

x1

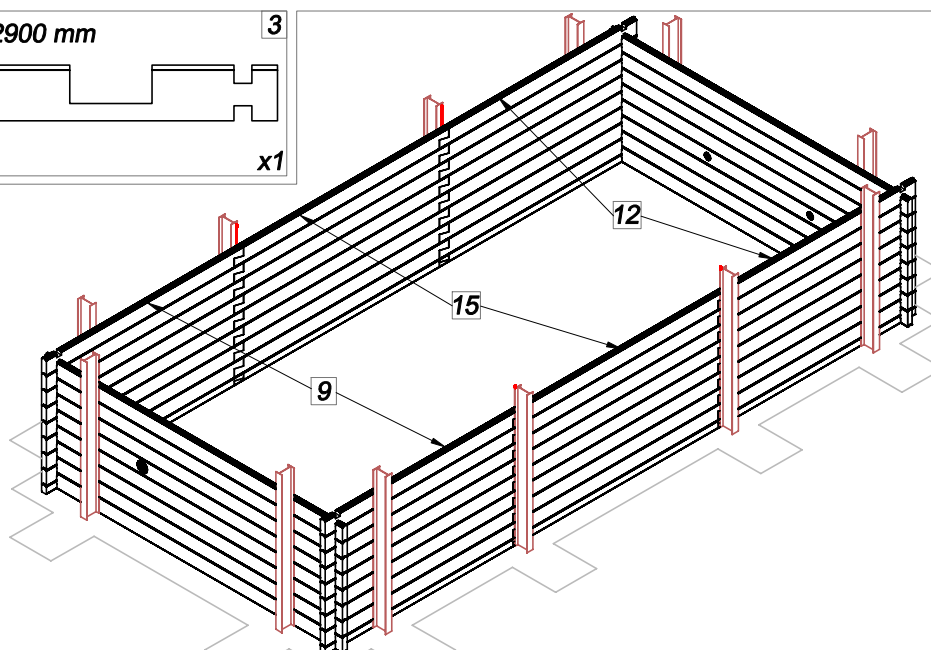

14

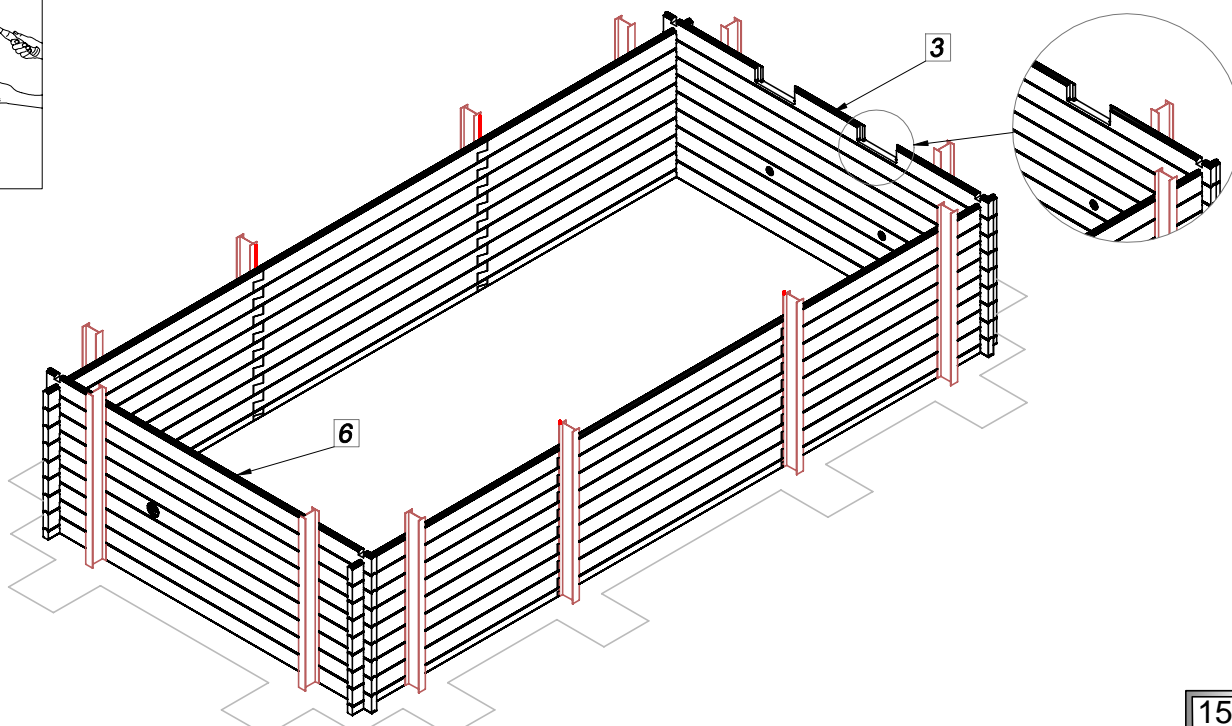
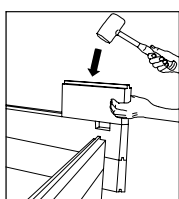

15

PL *Struktura drewniana*

GB *Wooden structure*

DE *Holzstruktur*

FR *La structure bois*

NL *Houten structuur*



PL Ułożenie kolejnych warstw. Sprawdź przekątną po każdej ułożonej warstwie.

FR L'assemblage des couches suivantes. Vérifiez la conformité des diagonales après la pose de chaque couche.

GB Arrangement of layers. Check diagonals after having arranged each layer.

DE Anordnung der Schichten. Überprüfen Sie die Diagonalen nachdem Sie jede Schicht angeordnet haben.

NL Opbouw van de lagen. Controleer de diagonalen na het aanbrengen van elke laag.

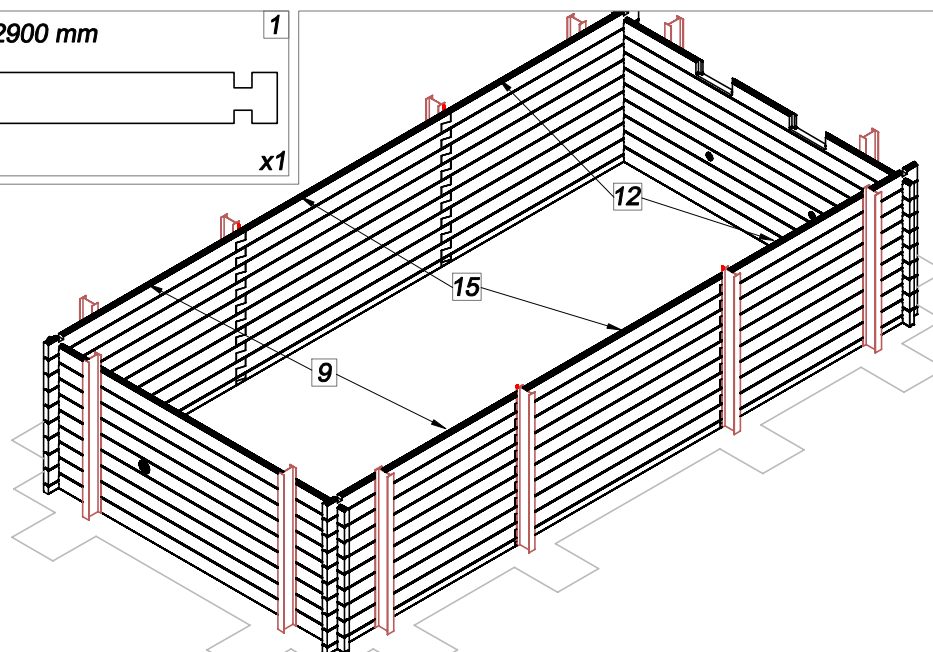
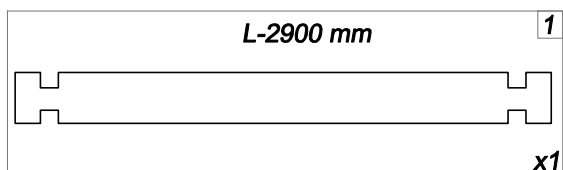
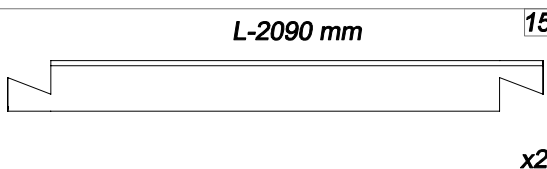
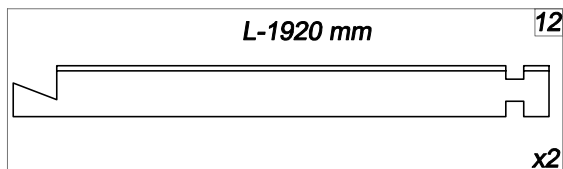
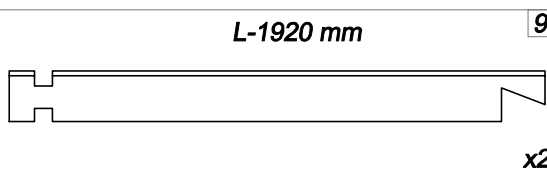
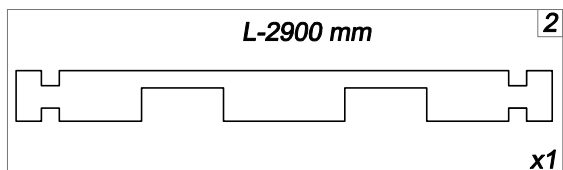

X

16

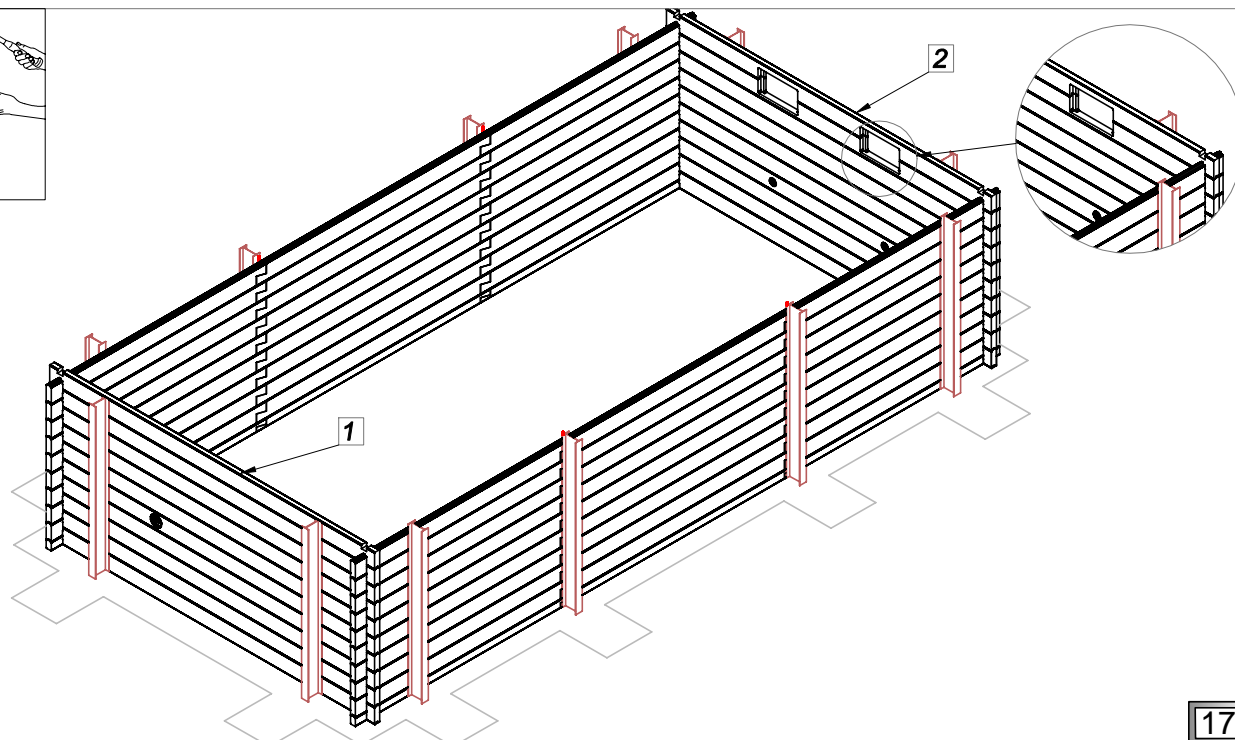
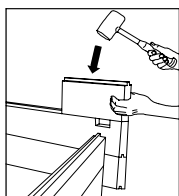

17

PL *Struktura drewniana*

GB *Wooden structure*

DE *Holzstruktur*

FR *La structure bois*

NL *Houten structuur*



PL Ułożenie kolejnych warstw. Sprawdź przekątną po każdej ułożonej warstwie.

FR L'assemblage des couches suivantes. Vérifiez la conformité des diagonales après la pose de chaque couche.

GB Arrangement of layers. Check diagonals after having arranged each layer.

DE Anordnung der Schichten. Überprüfen Sie die Diagonalen nachdem Sie jede Schichte angeordnet haben.

NL Opbouw van de lagen. Controleer de diagonalen na het aanbrengen van elke laag.

L-1920 mm

7

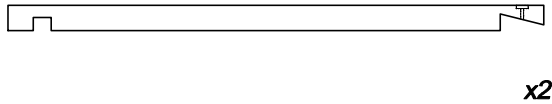

x2

L-1920 mm

10

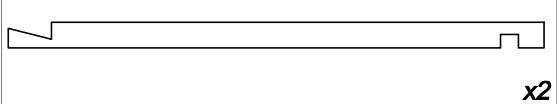

x2

L-2090 mm

13

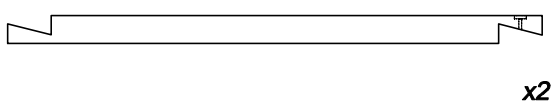

x2

O

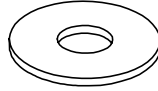

x4

6K-M8/13

K

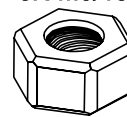

x4

XI

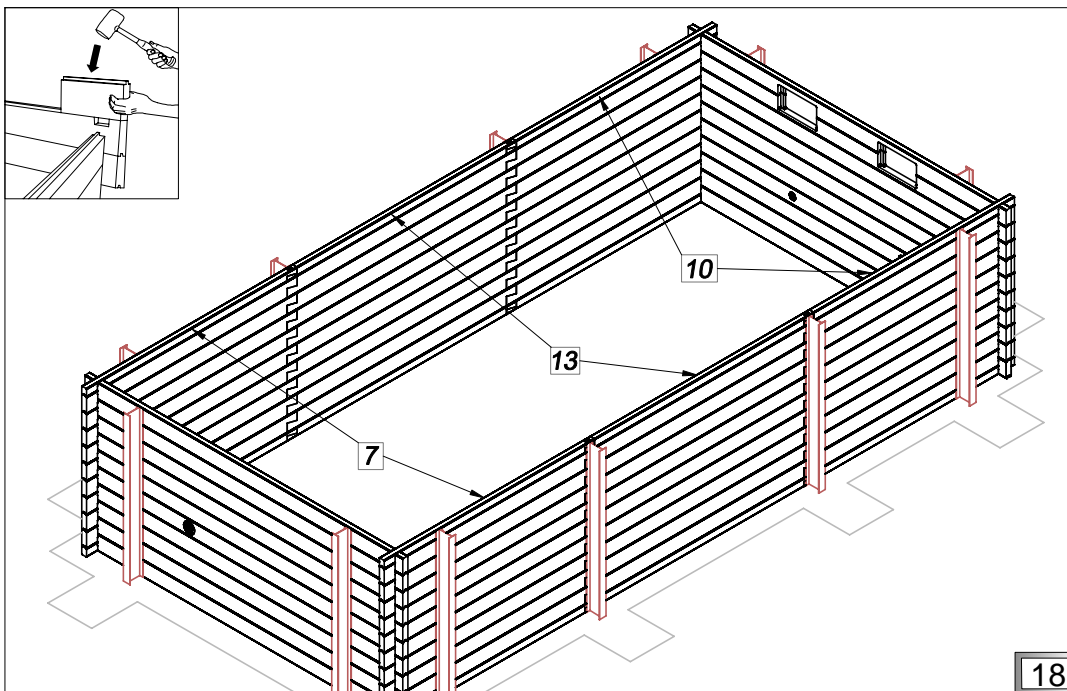
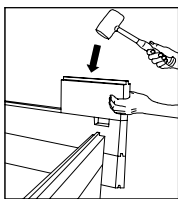

18

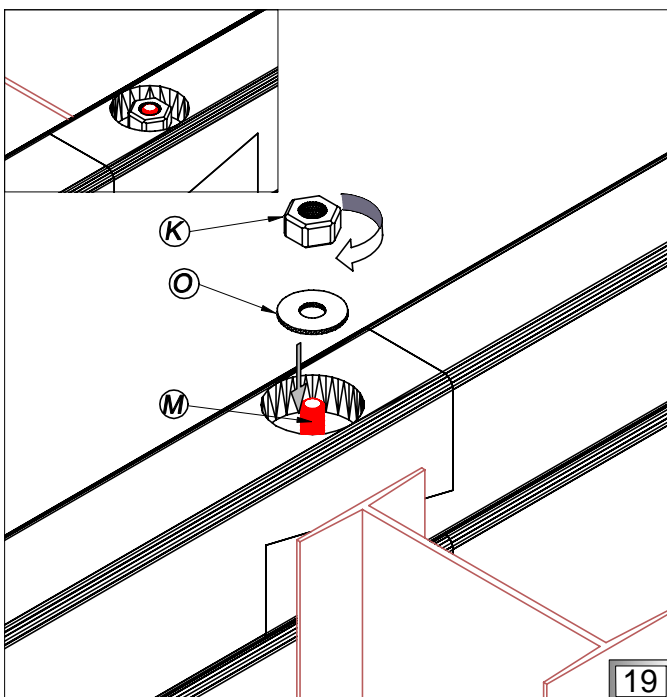
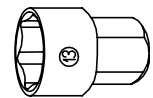
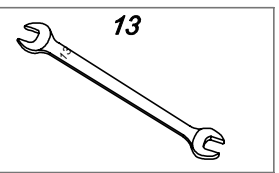

19

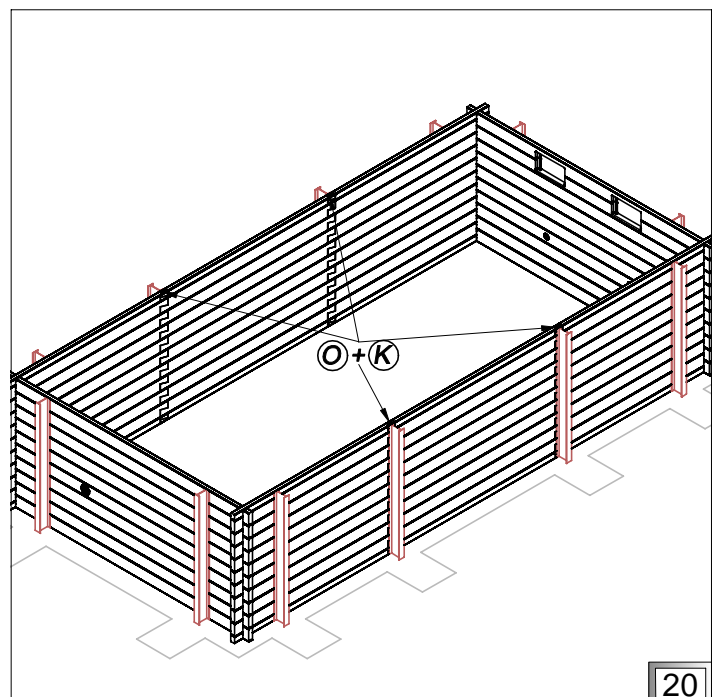

20

PL *Struktura drewniana*

GB *Wooden structure*

DE *Holzstruktur*

FR *La structure bois*

NL *Houten structuur*



PL Ułożenie kolejnych warstw. Sprawdź przekątną po każdej ułożonej warstwie.

FR L'assemblage des couches suivantes. Vérifiez la conformité des diagonales après la pose de chaque couche.

GB Arrangement of layers. Check diagonals after having arranged each layer.

DE Anordnung der Schichten. Überprüfen Sie die Diagonalen nachdem Sie jede Schichte angeordnet haben.

NL Opbouw van de lagen. Controleer de diagonalen na het aanbrengen van elke laag.

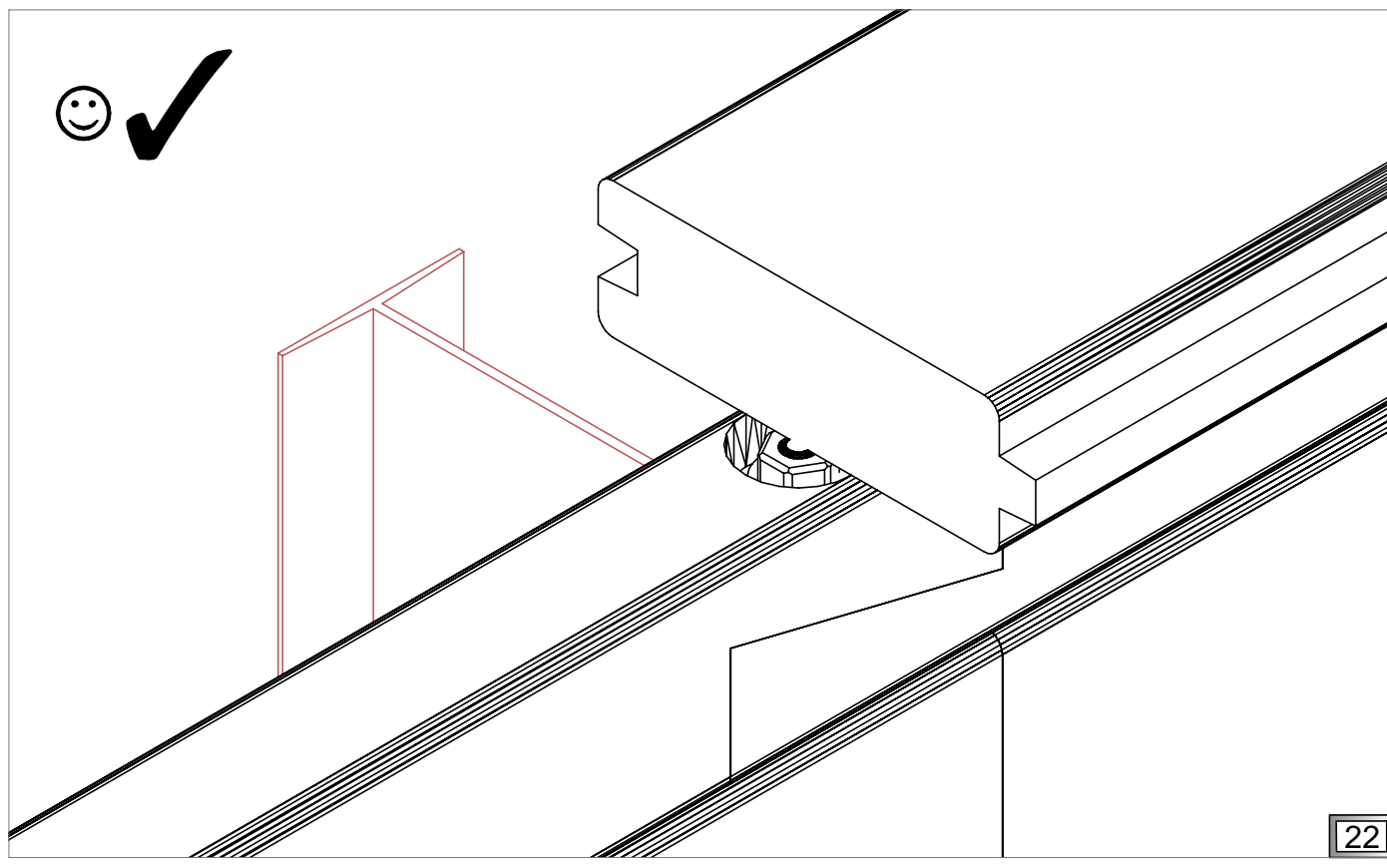
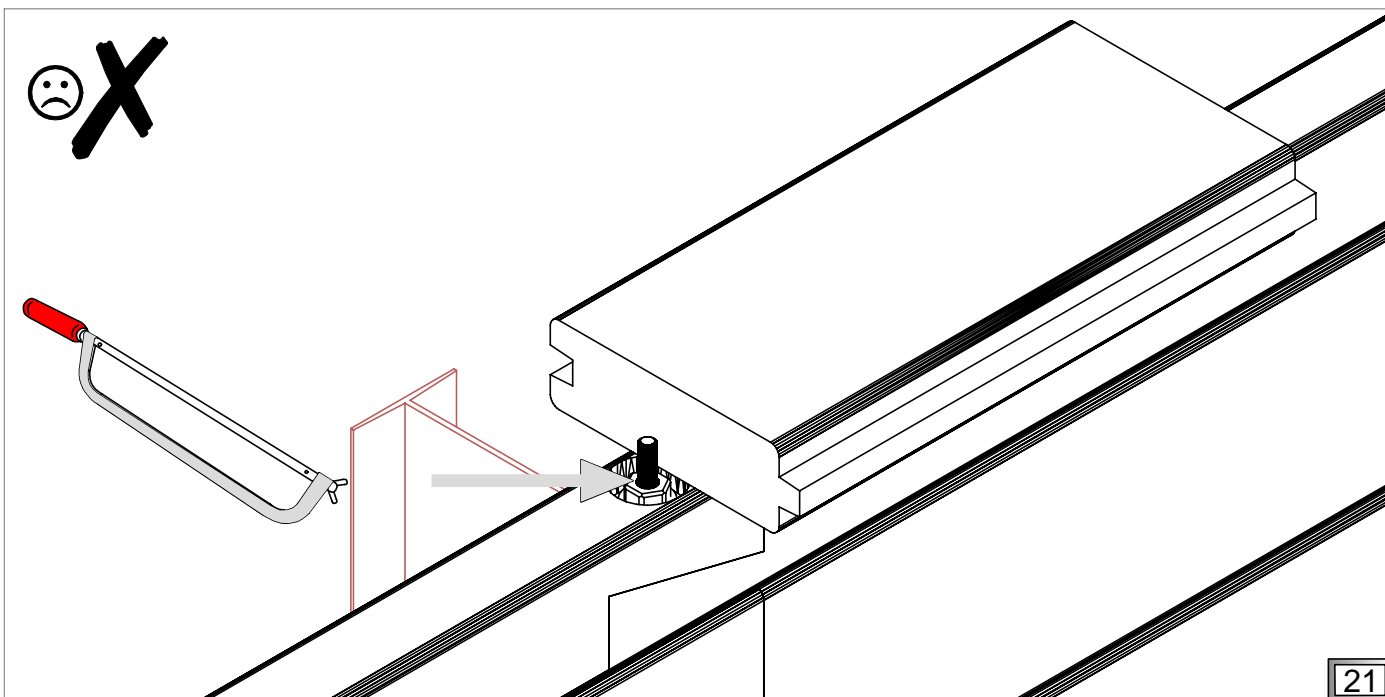
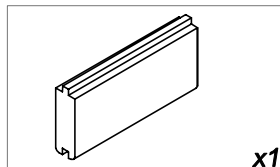
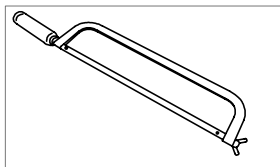

PL *Struktura drewniana*

GB *Wooden structure*

DE *Holzstruktur*

FR *La structure bois*

NL *Houten structuur*



- PL** Montaż wspornika schodów (27)
- FR** Le montage du renfort d'escalier (27).
- GB** Installation of stairs support (27).
- DE** Montage von Treppenstützen (27).
- NL** Installatie van trappensteun (27).

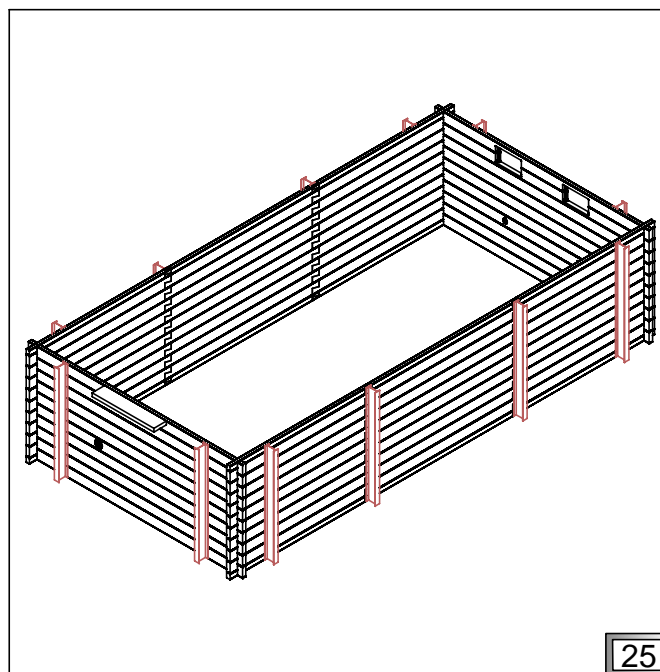
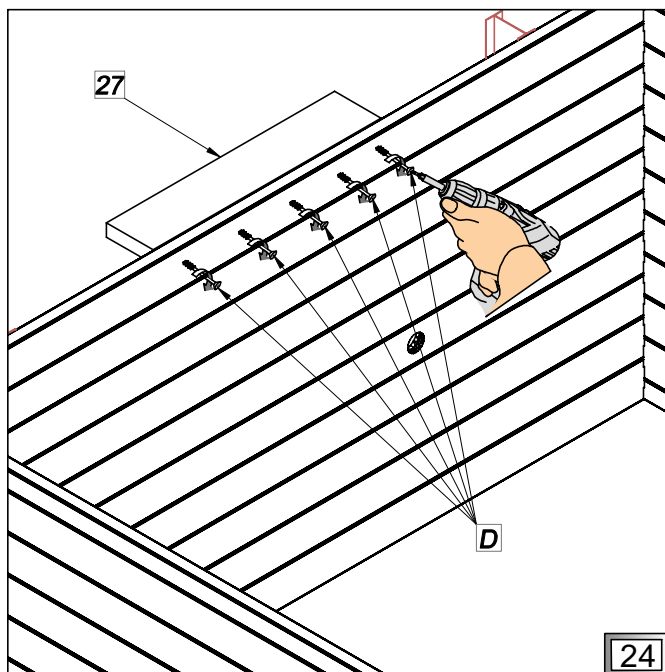
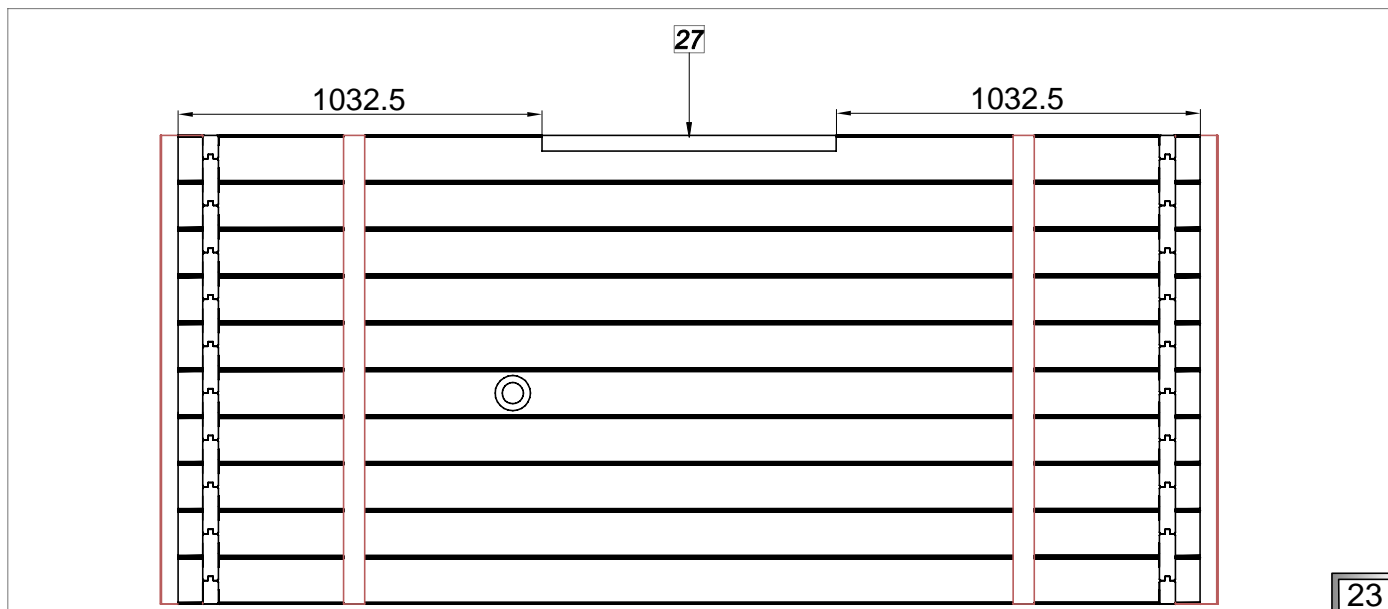
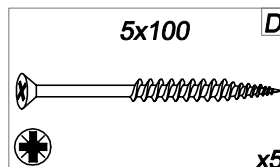
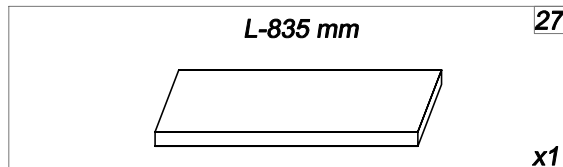
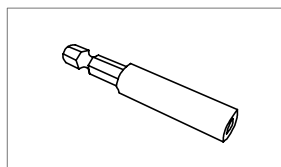
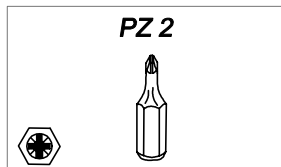
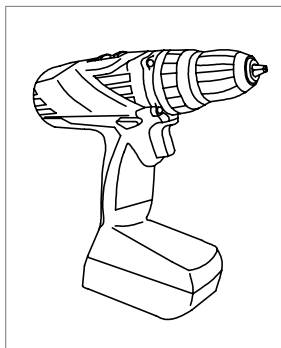

PL Struktura drewniana

GB Wooden structure

DE Holzstruktur

FR La structure bois

NL Houten structuur



PL Rozłożenie wsporników pionowych (28, 29) oraz konsol (33) według schematu.

FR La disposition des renforts verticaux (28, 29) et des supports des margelles (33) d'après le schéma.

GB Arrangement of vertical supports (28, 29) and consoles (33) according to the drawing.

DE Anordnung der vertikalen Stützen (28,29) und Konsolen (33) gemäß der Zeichnung.

NL Opstelling van verticale steunen (28, 29) en consoles (33) volgens de tekening.

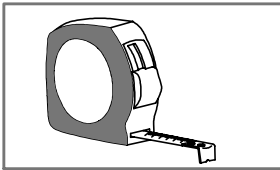

[mm]

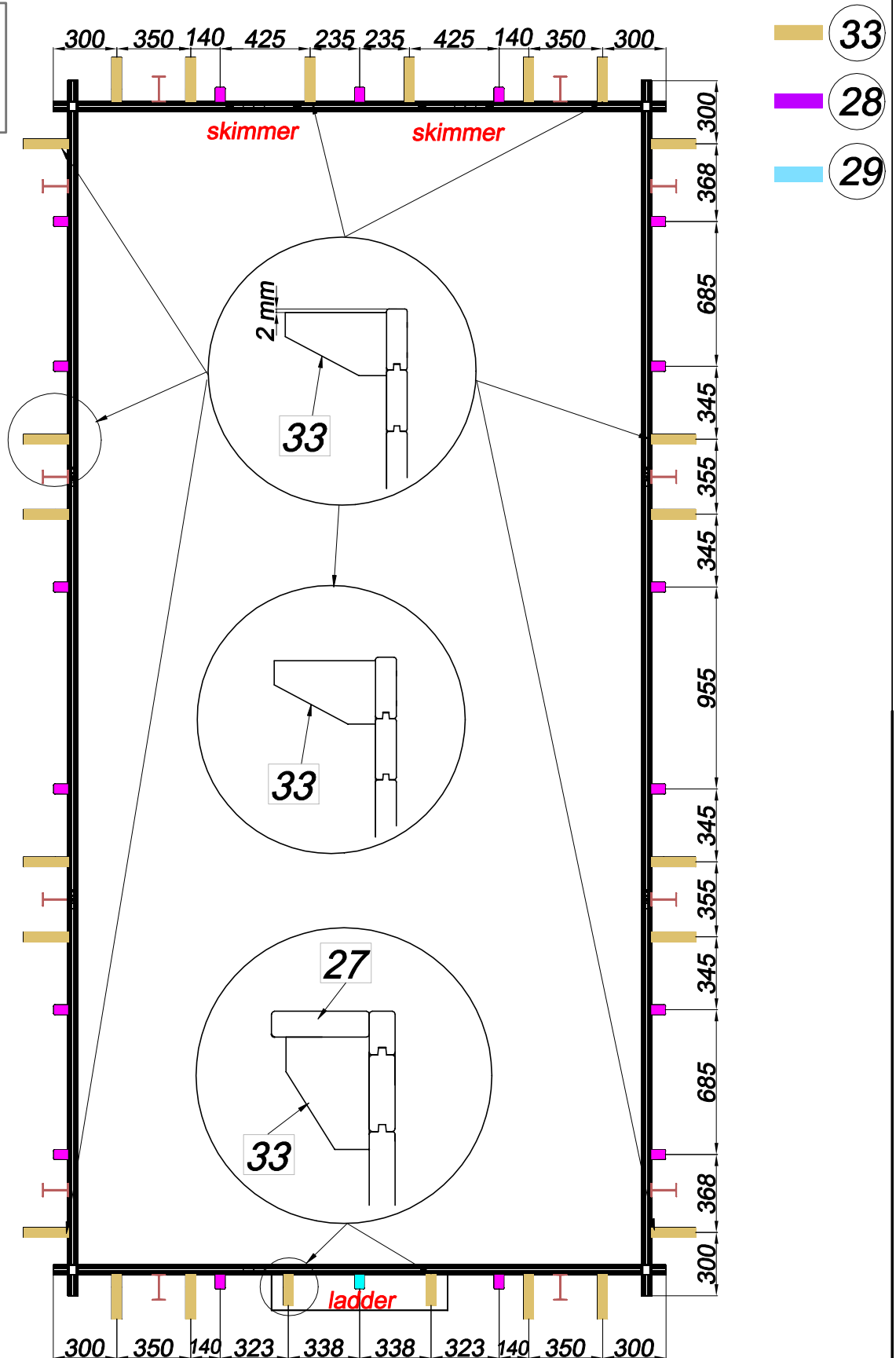

PL Struktura drewniana

GB Wooden structure

DE Holzstruktur

FR La structure bois

NL Houten structuur



PL Montaż konsol (33). Konsole montowane pod wspornikiem schodów (27) według rysunku 29-30.

FR Montage des supports des margelles (33). Montez les supports des margelles sous le renfort d'escalier (27) d'après le dessin 29-30.

GB Installation of consoles (33). Consoles under ladder support (27) installed according to the drawing 29-30.

DE Installation der Konsolen (33). Konsolen unter Leiterabstützung installiert (27) Schrauben entsprechend der Zeichnung anordnen 29-30.

NL Installatie van consoles (33). Consoles geïnstalleerd onder laddersteun (27) breng de schroeven aan volgens de tekening 29-30.

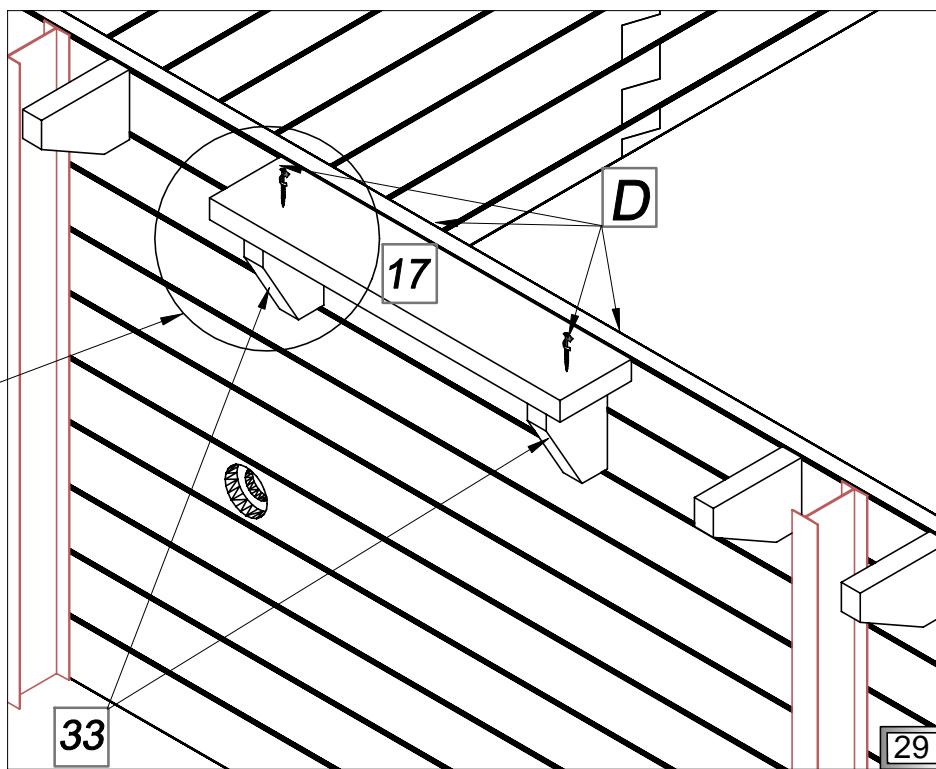
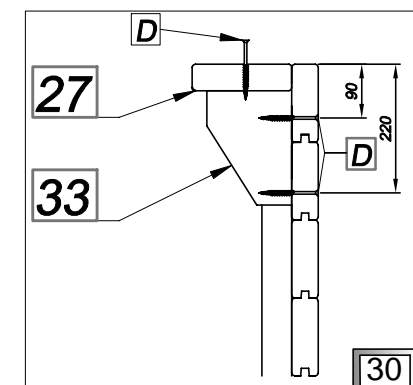
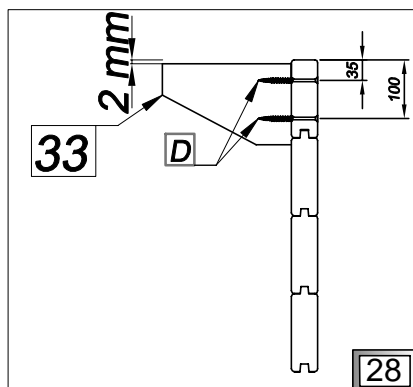
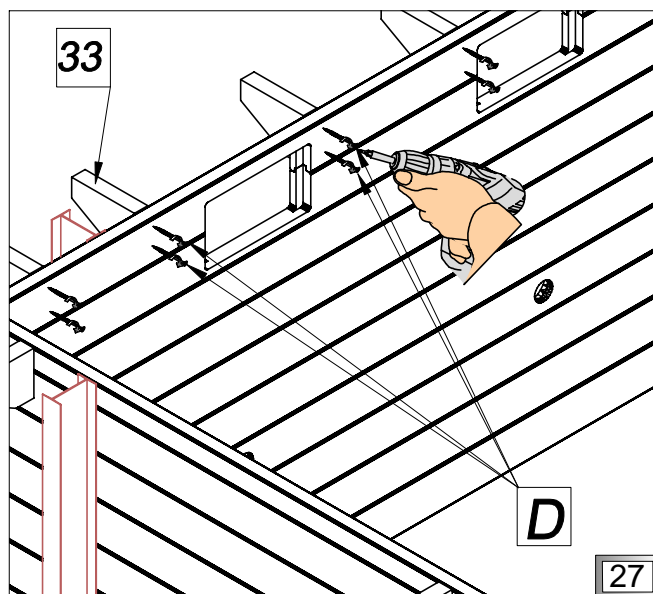
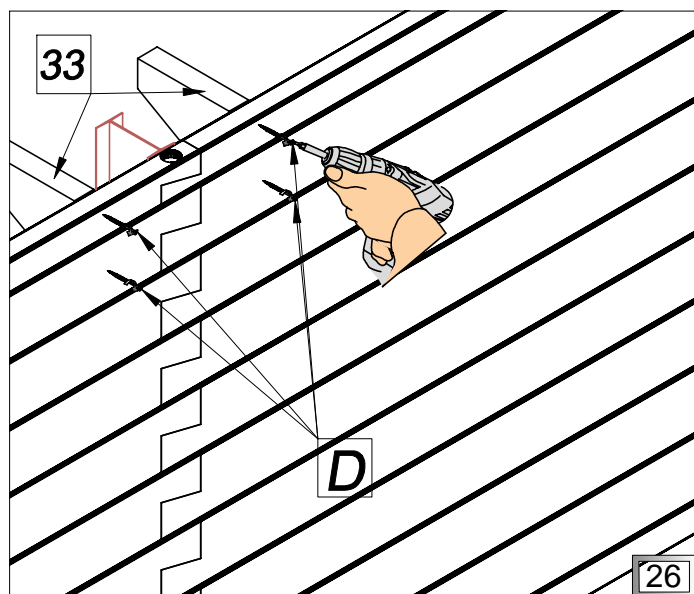
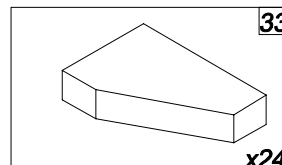
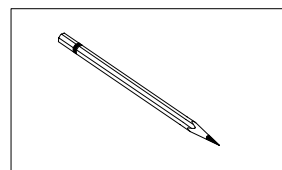
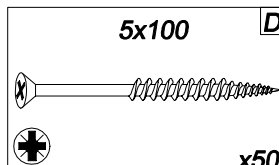
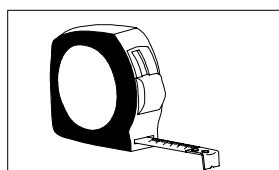
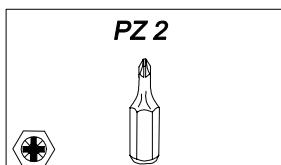
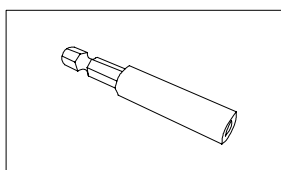
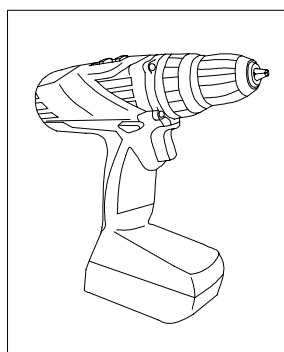

PL Struktura drewniana

GB Wooden structure

DE Holzstruktur

FR La structure bois

NL Houten structuur



PL Montaż wsporników pionowych (28). Wkręty rozmieszczaj według rysunku 32.

FR Montage des renforts verticaux (28). Disposer les vis selon le dessin 32.

GB Installation of vertical supports (28). Arrange screws according to the drawing 32.

DE Installation von vertikalen Stützen (28). Schrauben entsprechend der Zeichnung anordnen 32.

NL Installatie van verticale steunen (28). Breng de schroeven aan volgens de tekening 32.

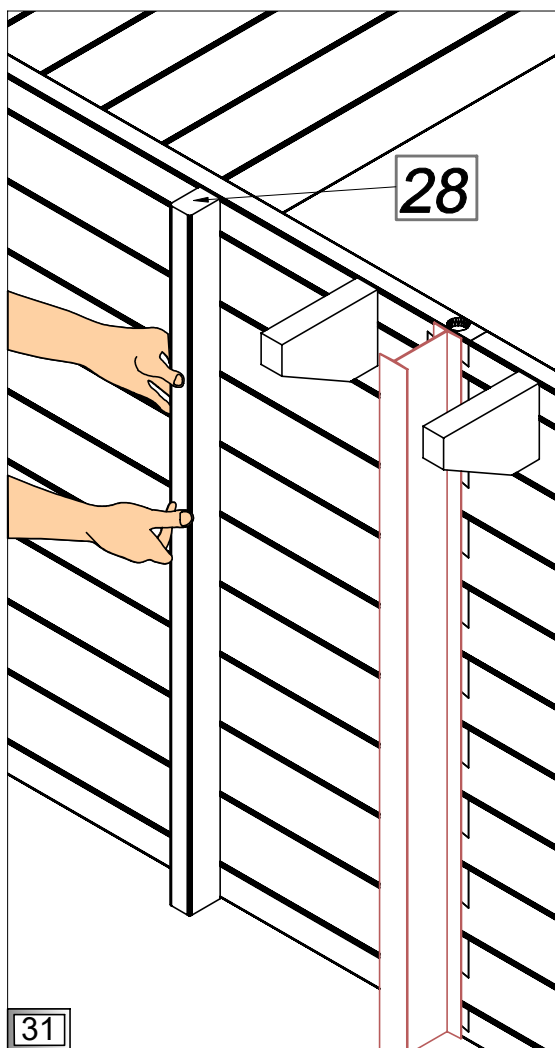
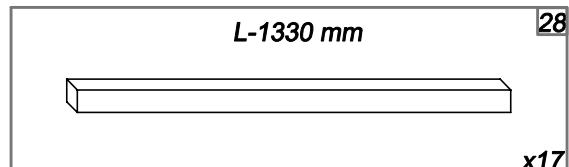
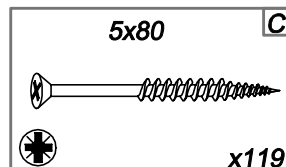
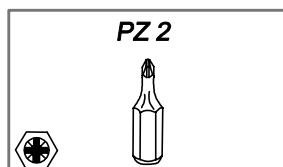
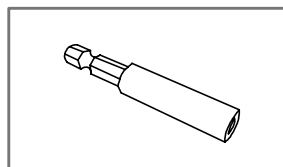
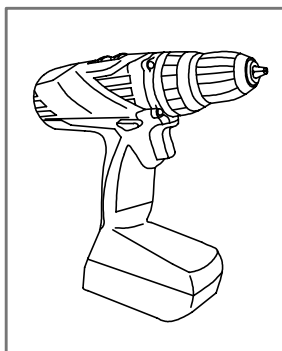

31

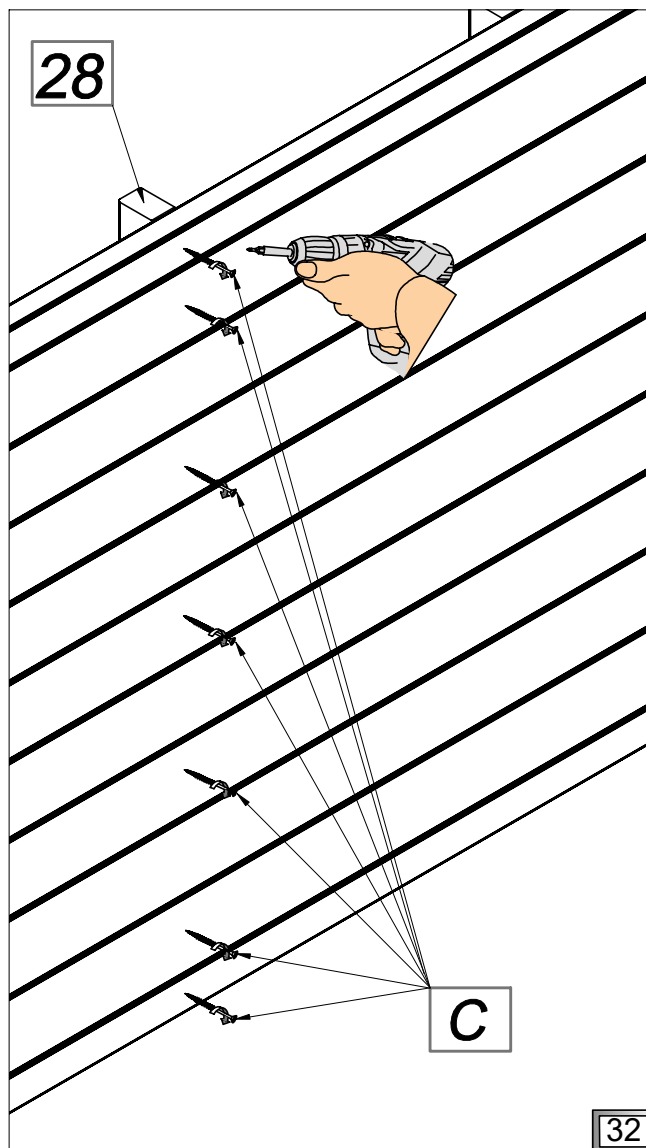

32

PL Struktura drewniana

GB Wooden structure

DE Holzstruktur

FR La structure bois

NL Houten structuur



PL Montaż wsporników pionowych (29) pod wspornikiem schodów (33).

FR Montage des renforts verticaux (29) sous le renfort d'escalier (33).

GB Installation of vertical supports (29) under the ladder support (33).

DE Installation von vertikalen Stützen (29) unter der Leiterunterstützung (33).

NL Installatie van verticale steunen (29) onder de laddersteun (33).

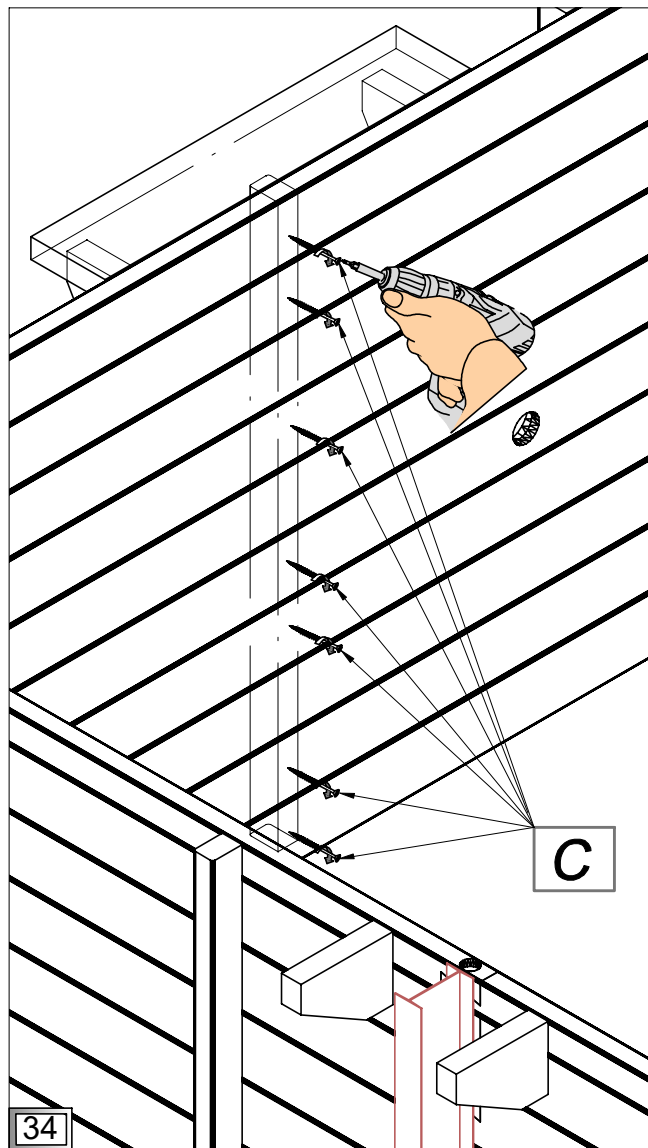
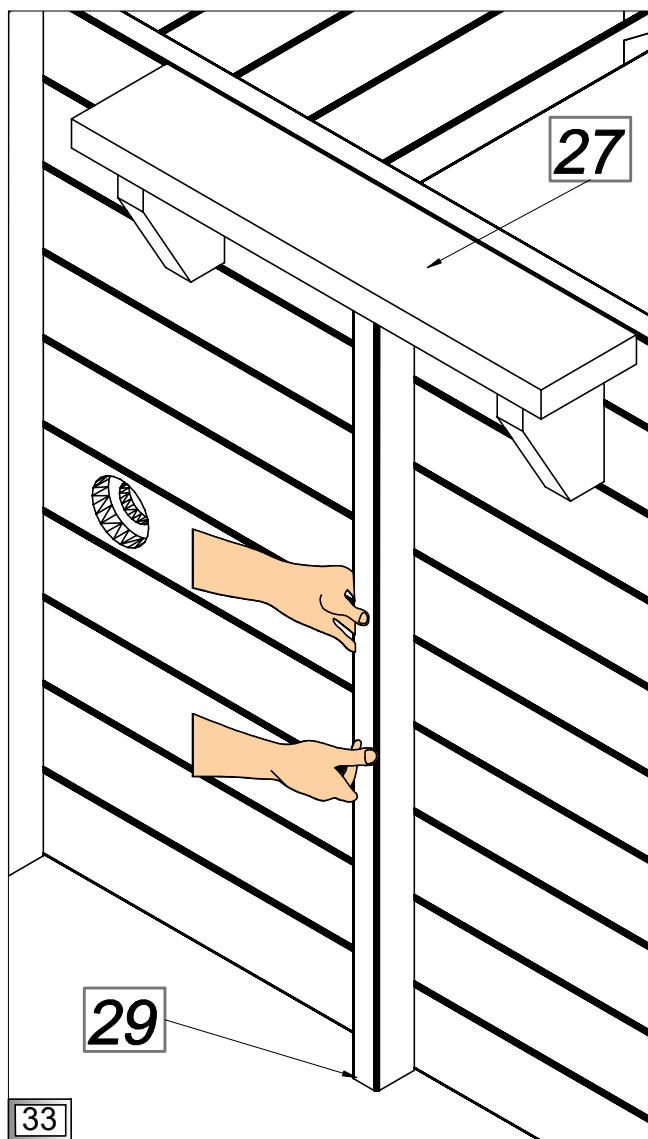
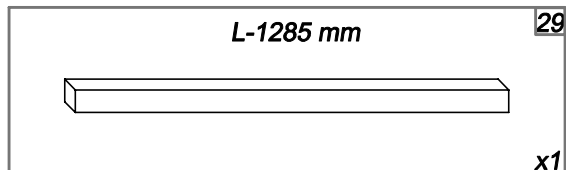
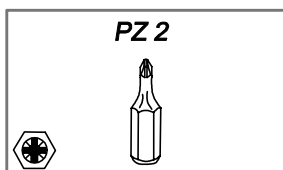
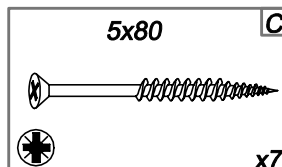
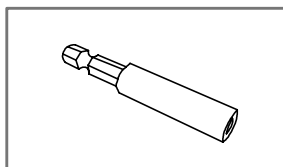
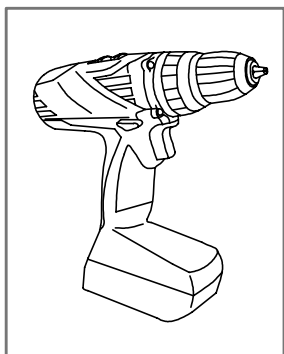

PL Struktura drewniana

GB Wooden structure

DE Holzstruktur

FR La structure bois

NL Houten structuur



- PL** Maskowanie słupków metalowych 2T (I) maskownicami (30,31).
- FR** Fixation des caches (30,31) pour les poteaux métalliques 2T (I).
- GB** Covering steel bars 2T (I) with masking elements (30,31).
- DE** Stahlstangen 2T (I) mit Abdeckelementen abdecken. (30,31).
- NL** Bedekking van stalen stangen 2T (I) met maskeerelementen (30,31).

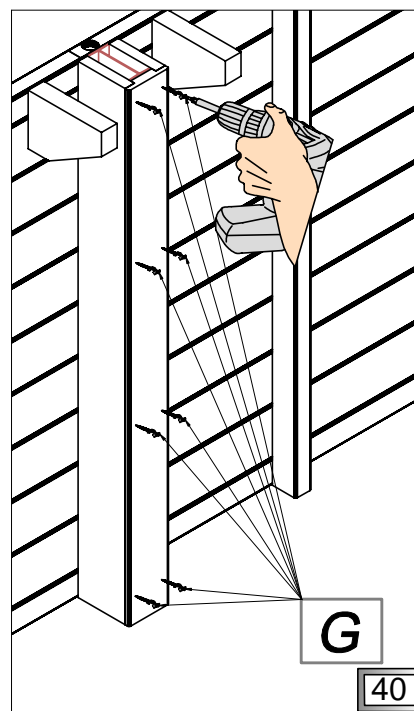
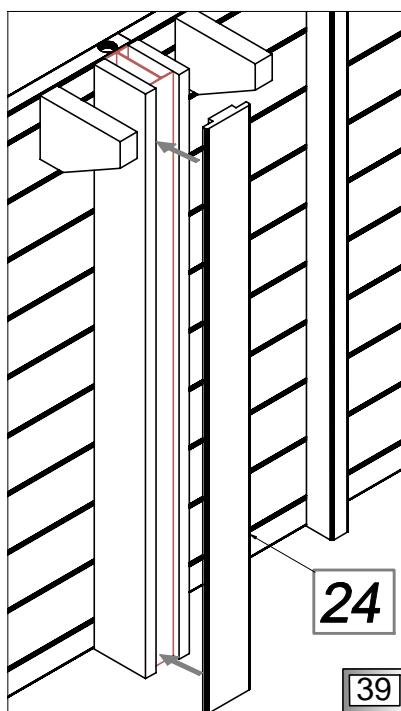
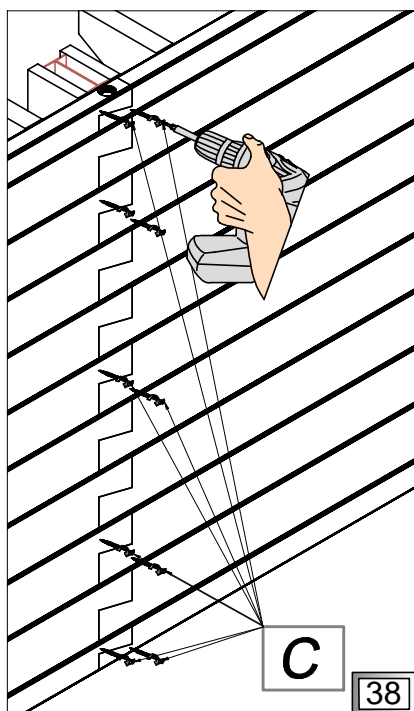
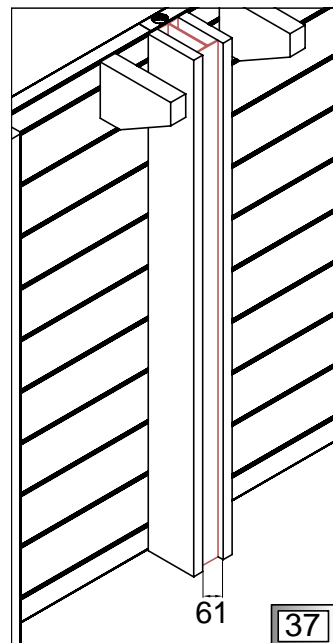
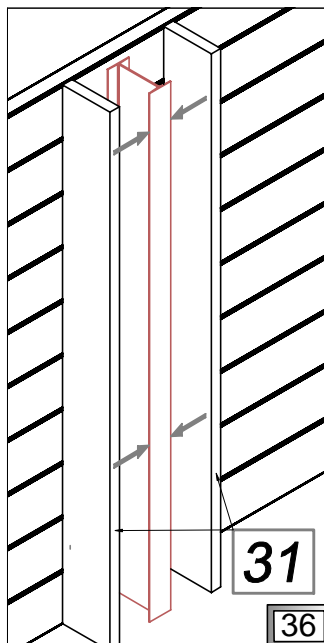
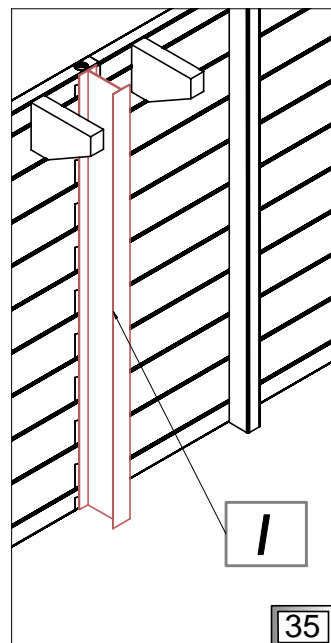
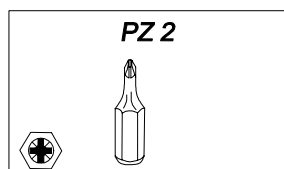
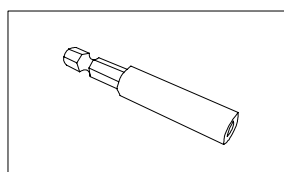
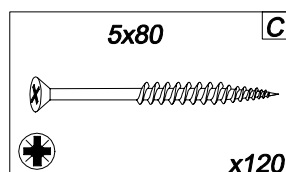
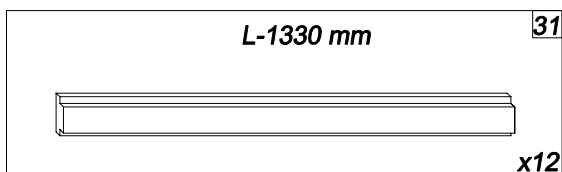
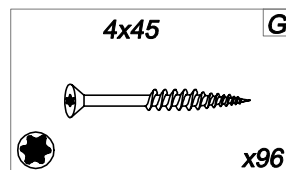
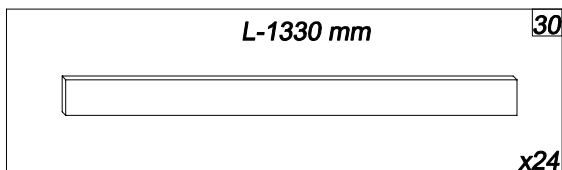
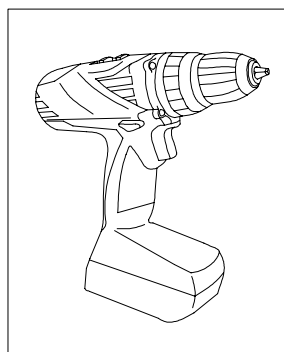

PL Struktura drewniana

GB Wooden structure

DE Holzstruktur

FR La structure bois

NL Houten structuur



- PL** Montaż maskownicy U (32).
- FR** Montage des caches U (32).
- GB** Installation of the masking element U (32).
- DE** Installation der Abdeckelemente U (32).
- NL** Installatie van het maskeerelement U (32).

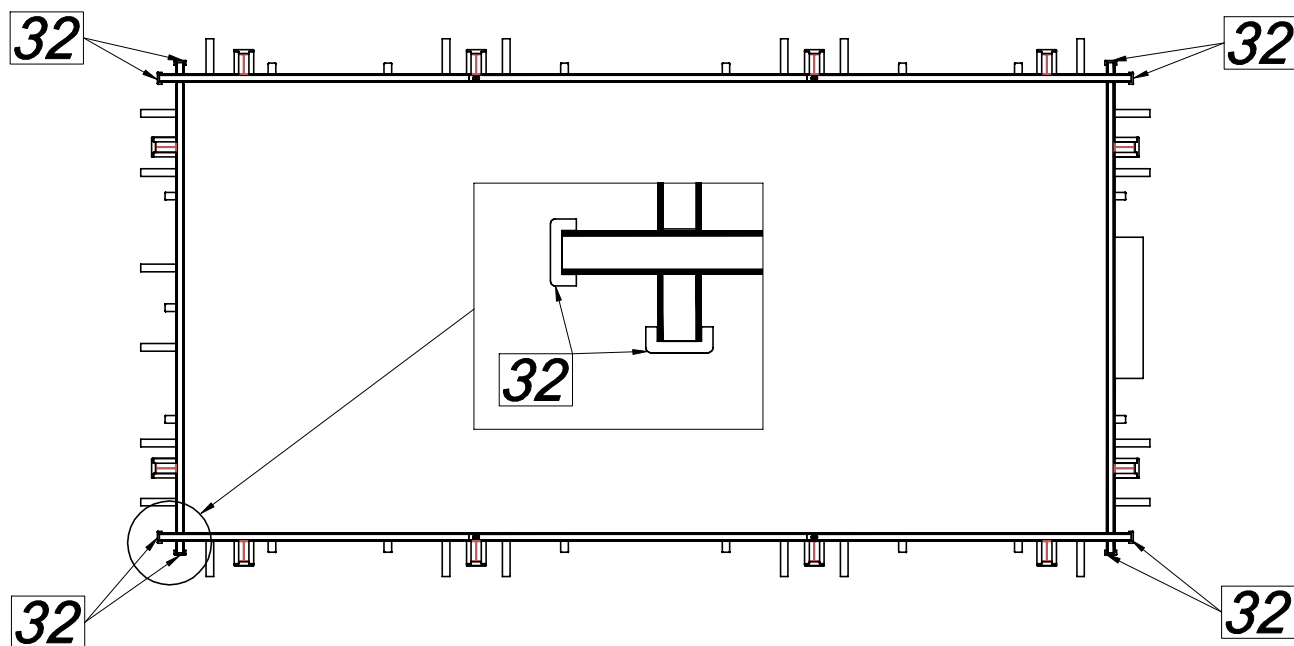
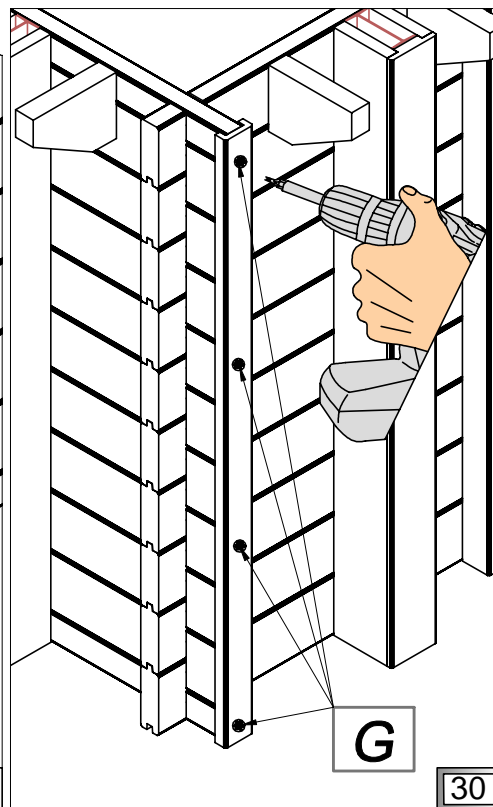
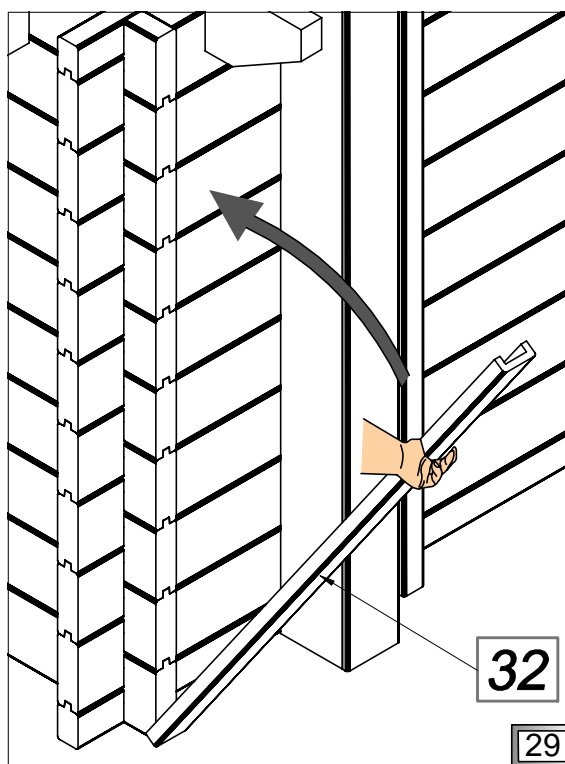
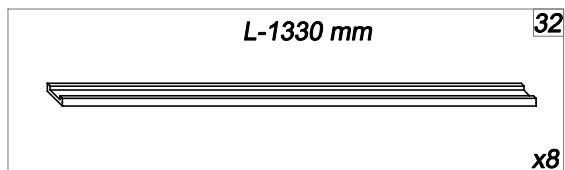
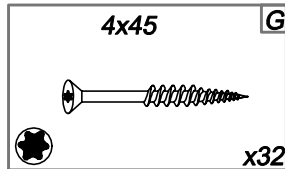
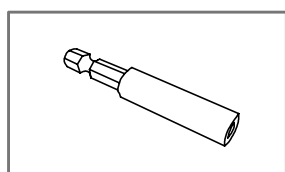
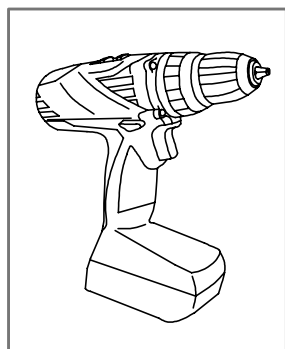

PL Geowłóknina

GB Geotextile

DE Geotextilien

FR Géotextile

NL Geotextiel



PL Rozłożenie geowłókniny (U). Nakleić włókninę na wewnętrzną stronę basenu za pomocą taśmy 2-stronnej bądź kleju.

FR La pose du feutre (U). Collez le feutre a l'interieur de la structure à l'aide de colle ou de ruban adhésif double face.

GB Distribution of geotextile (U). Glue the geotextile to the inner side of pool wall. Use double-side tape or glue.

DE Verteilung von Geotextil (U). Kleben Sie das Geotextil an die Innenseite der Poolwand. Verwenden Sie doppelseitiges Klebeband oder Kleber.

NL Distributie van geotextiel (U). Lijm het geotextiel aan de binnenkant van de zwembadwand. Gebruik dubbelzijdige tape of lijm.

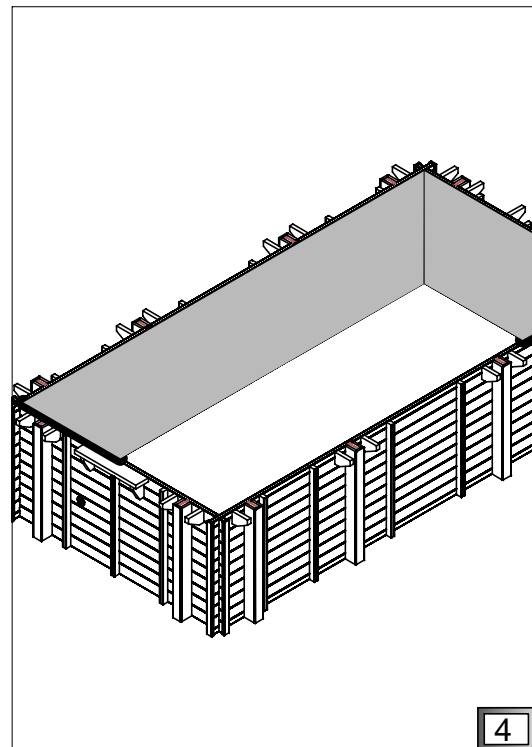
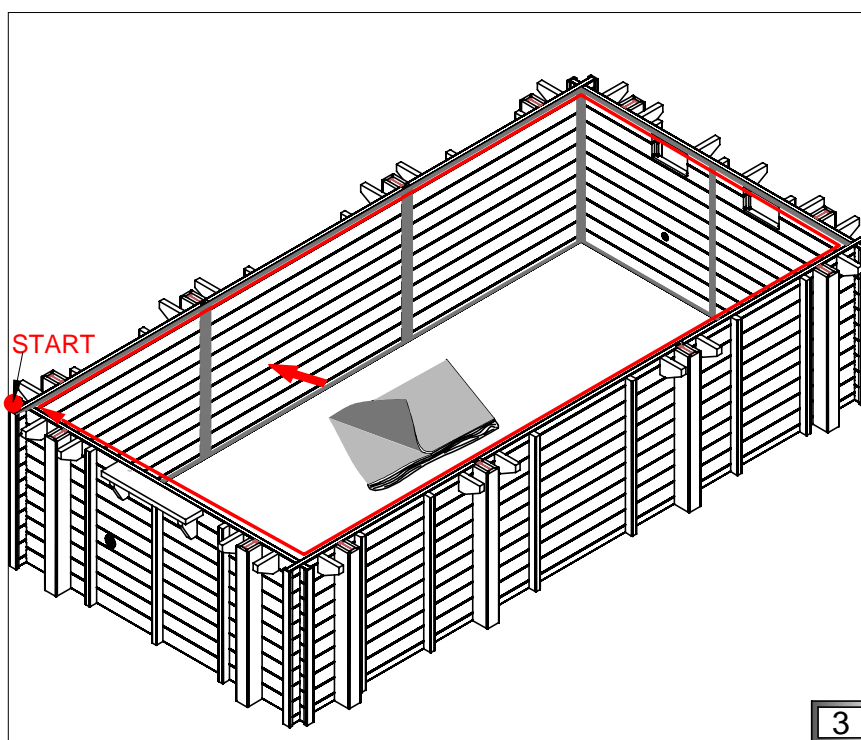
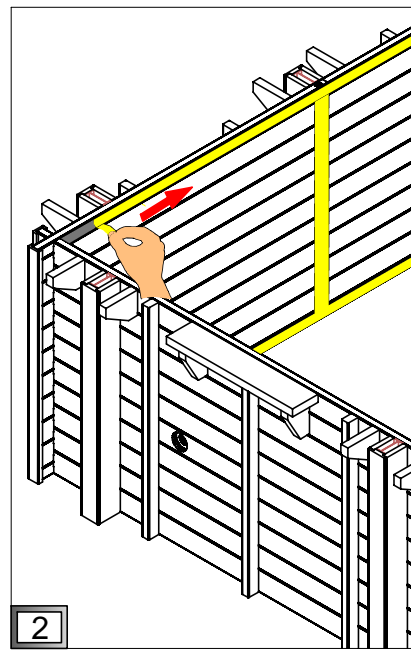
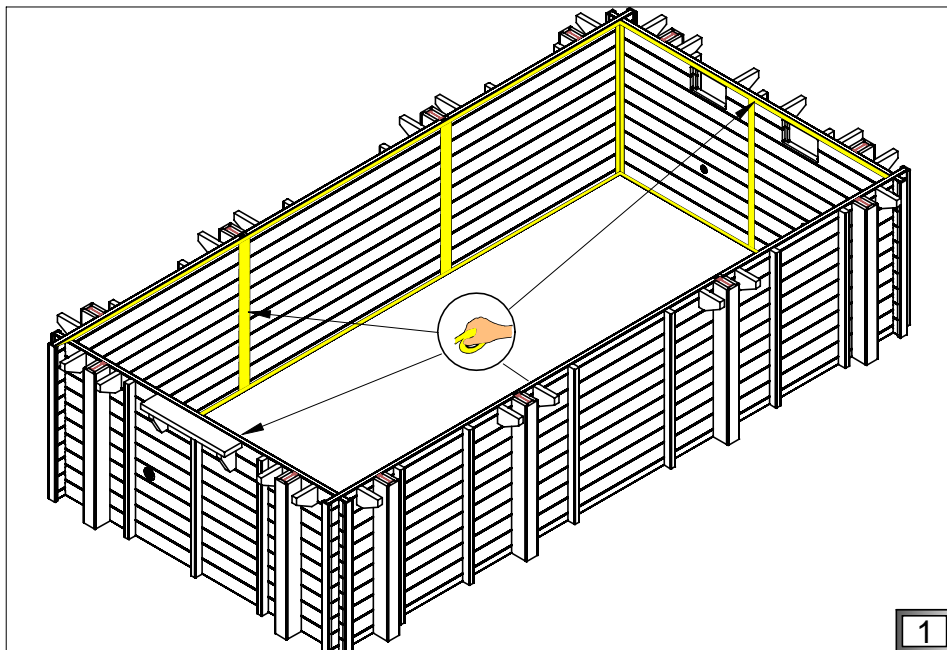
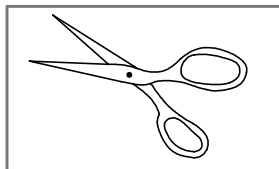
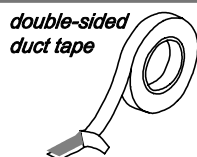
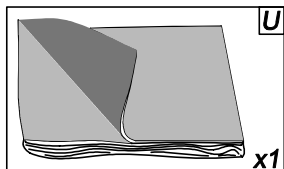

(PL) Profile PVC

(GB) PVC profiles

(DE) PVC-Profil

(FR) Les profils PVC

(NL) PVC-profielen



(PL) Profile PVC (J) przyciąć na wymiar. Wykonać otwory $\varnothing 2$ mm wg schematu.

(FR) Coupez les profilés PVC (J) d'accrochage et faites les pré-perçements $\varnothing 2$ mm d'après le schéma.

(GB) Cut PVC profiles (J) according to the drawing. Make holes $\varnothing 2$ mm according to the scheme.

(DE) Schneiden Sie PVC-Profil (J) gemäß der Zeichnung ab. Machen Sie anhand des Schemas Löcher von $\varnothing 2$ mm.

(NL) Snijd PVC-profielen (J) volgens de tekening. Maak gaten van $\varnothing 2$ mm volgens het schema.

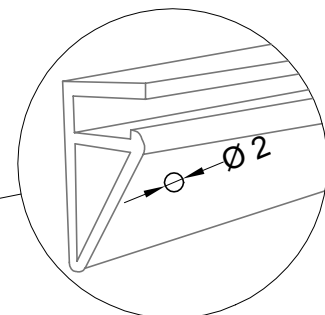
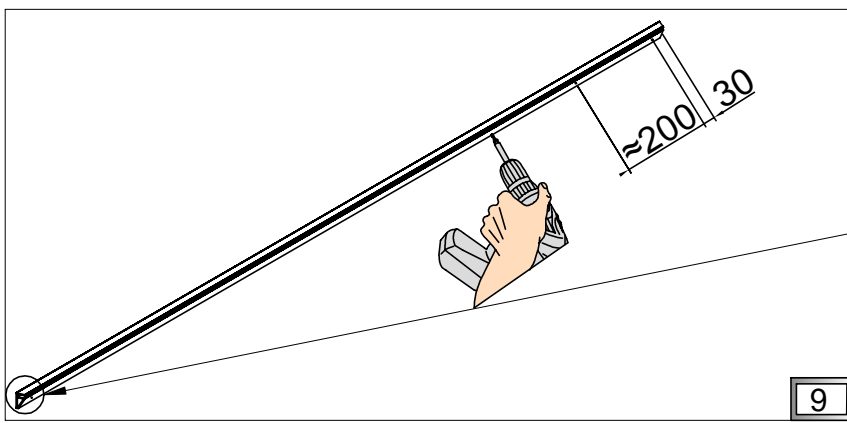
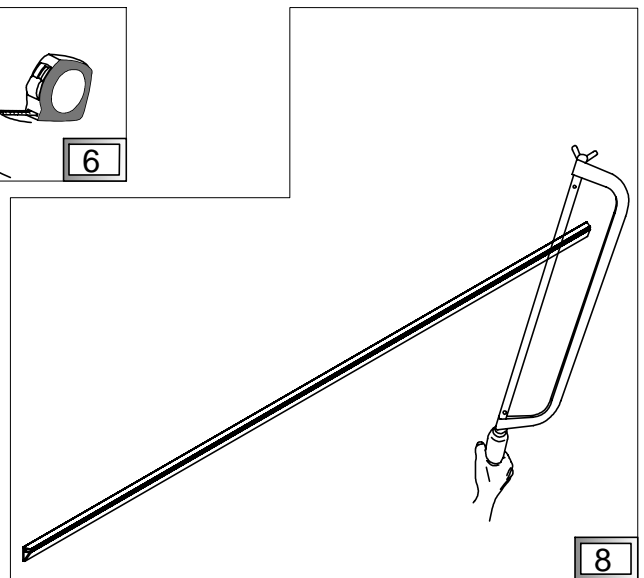
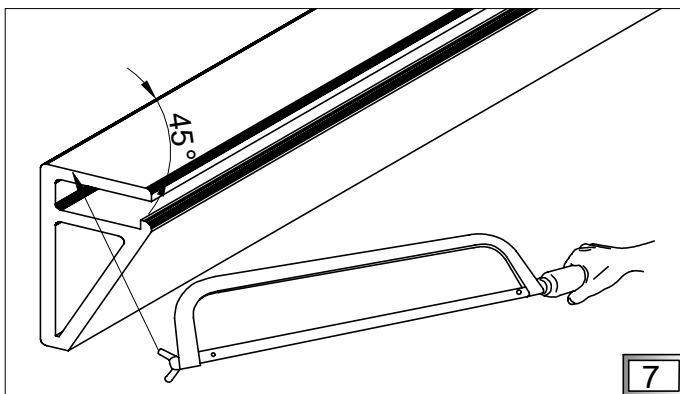
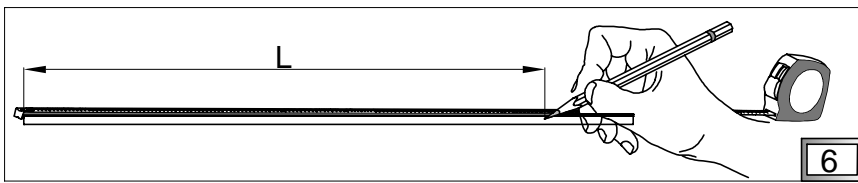
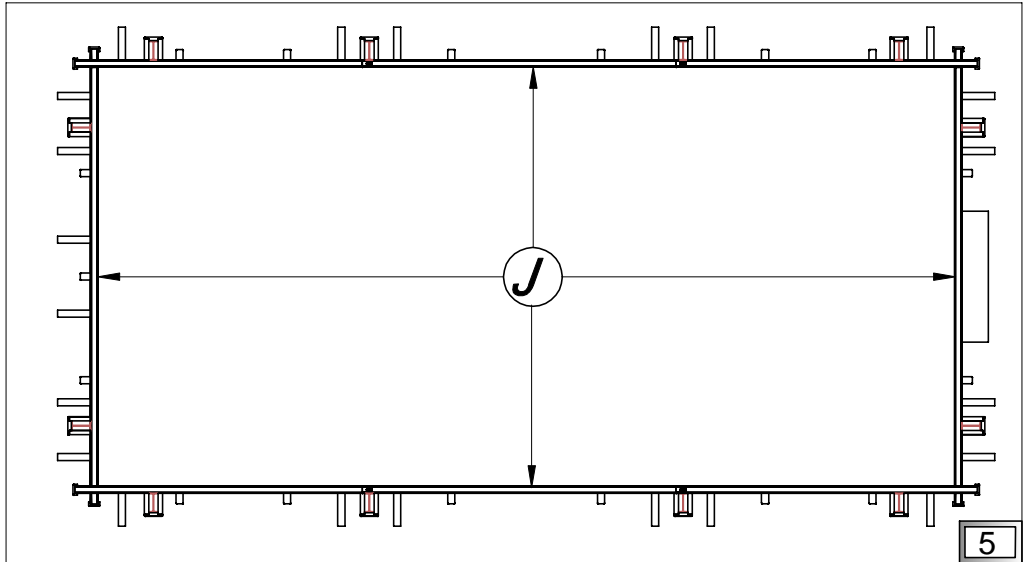
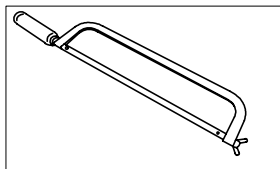
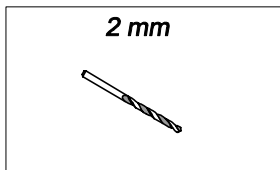
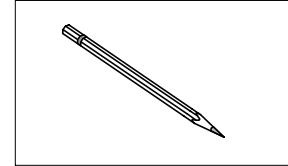
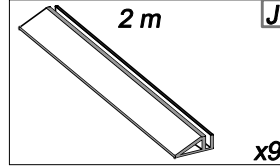
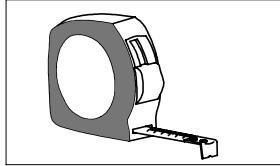
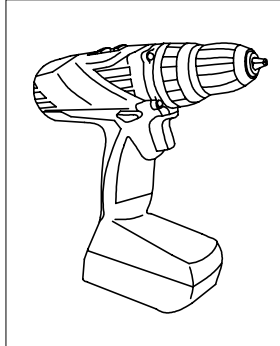

(PL) Profile PVC

(GB) PVC profiles

(DE) PVC-Profile

(FR) Les profils PVC

(NL) PVC-profielen



(PL) Montaż profili PVC (J) do struktury drewnianej. Profile (J) łączymy na żądaną długość.

(FR) Montage des profils d'accrochage PVC (J) à la structure. Ajoutez les profilés (J) les uns aux autres pour obtenir la longueur souhaitée.

(GB) Mounting PVC profiles (J) to the wooden structure. Join profiles (J) to achieve desired length.

(DE) Montage von PVC-Profilen (J) an der Holzkonstruktion. Verbinden Sie Profile (J), um die gewünschte Länge zu erreichen.

(NL) PVC-profielen (J) aan de houten structuur koppelen. Voeg profielen (J) samen om de gewenste lengte te bereiken.

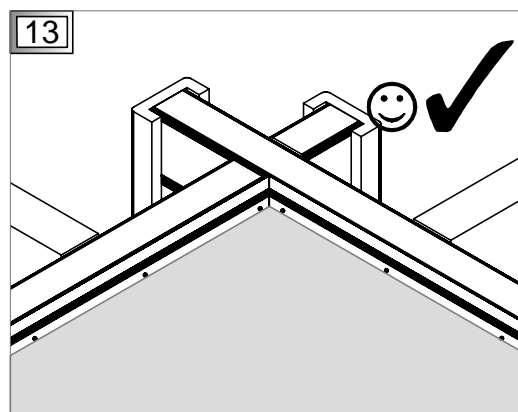
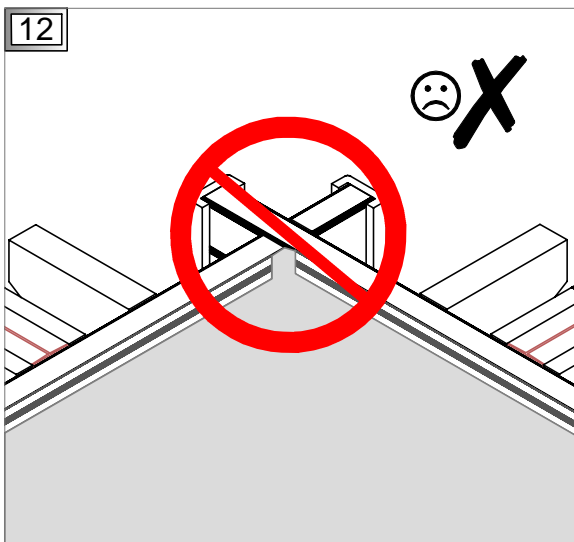
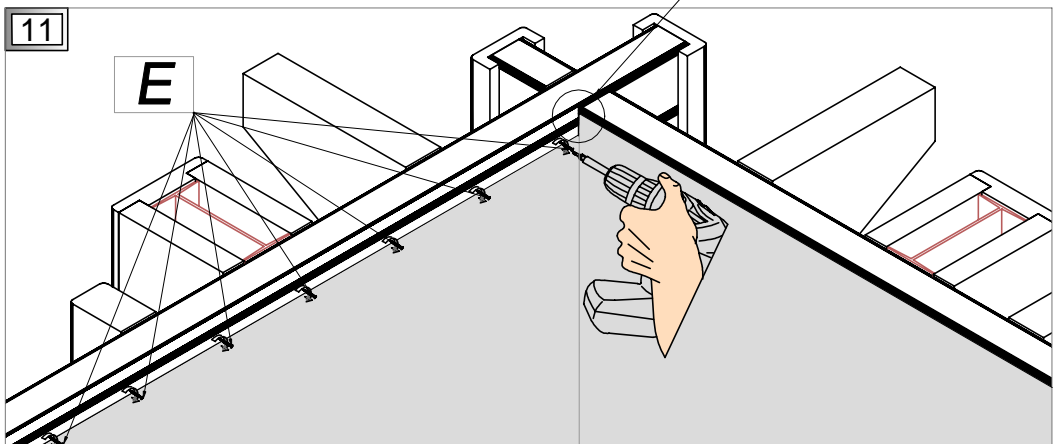
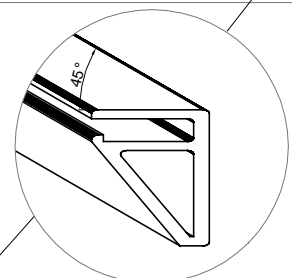
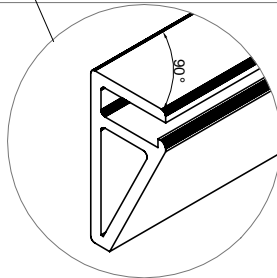
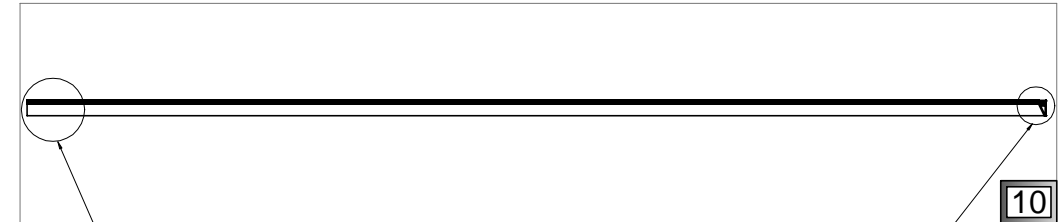
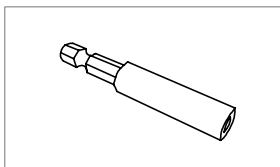
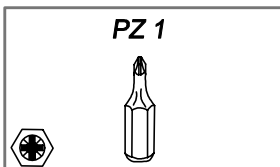
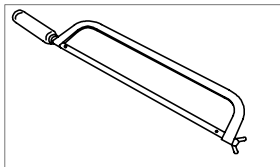
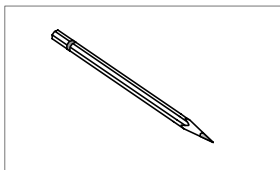
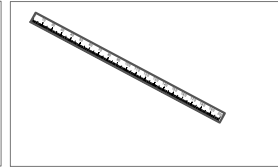
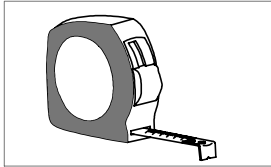
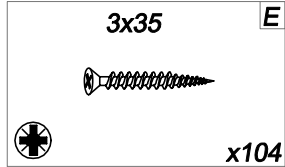
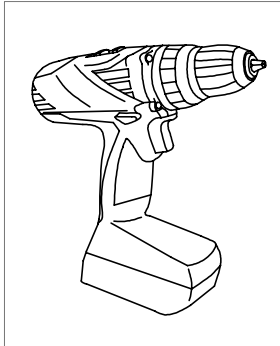

(PL) Geowłóknina i liner

(GB) Geotextile and liner

(DE) Geotextilien und Futter

(FR) Géotextile et liner.

(NL) Geotextiel en voering



(PL) Rozłożenie geowłókniny (W). Wycięcie otworów na skimmer i dyszę, odrysuj od elementów P4 i P16

(FR) Mise en place du feutre (W). Dessiner des emplacements pour les éléments P4 et P16. Découper des trous pour l'écumoire et la buse.

(GB) Installation of the geotextile (W). Draw places for elements P4 and P16. Cut holes for the skimmer and nozzle.

(DE) Installation des Geotextils (W). Zeichnen Sie Stellen für die Elemente P4 und P16. Schneiden Sie Löcher für den Skimmer und die Düse.

(NL) Installatie van het geotextiel (W). Teken de plaatsen voor elementen P4 en P16. Snijd gaten voor de skimmer en de jet straal.

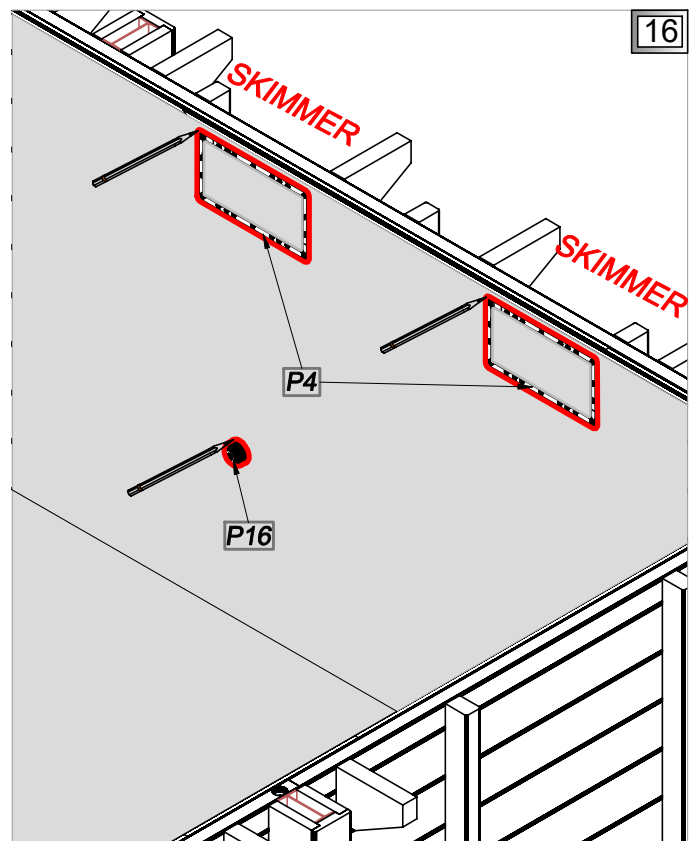
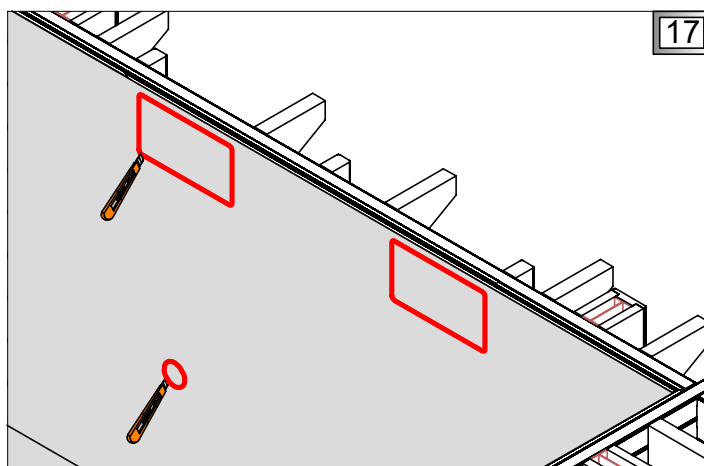
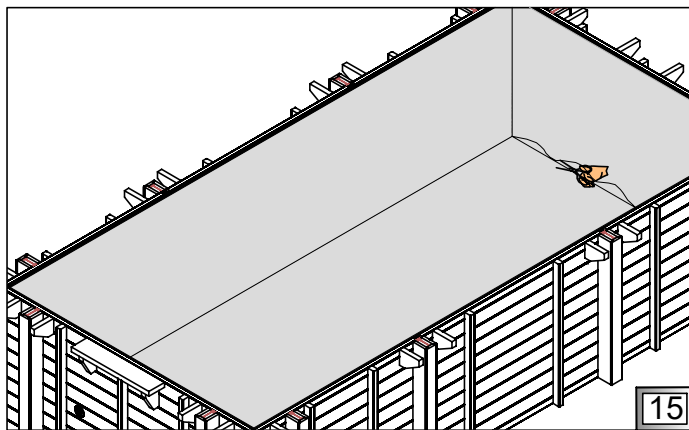
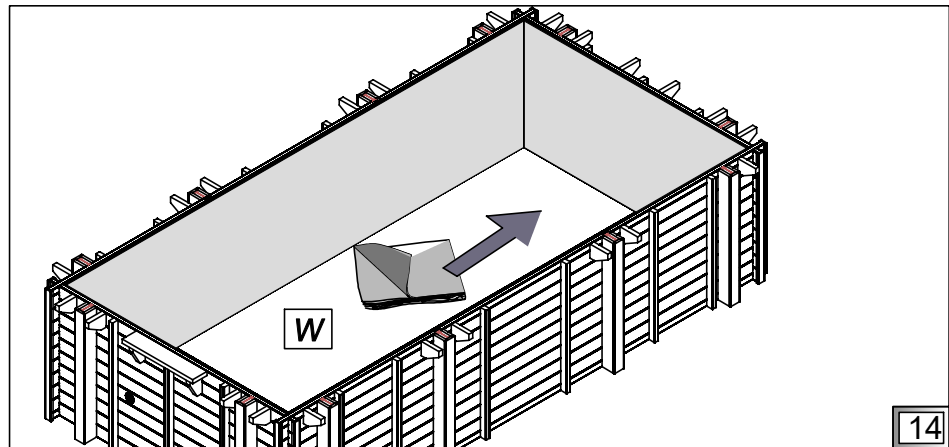
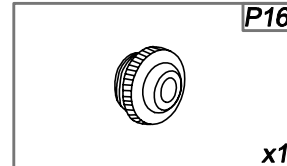
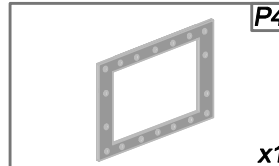
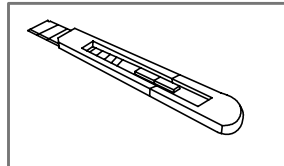
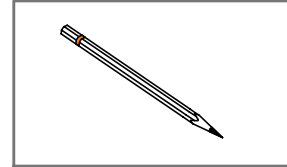
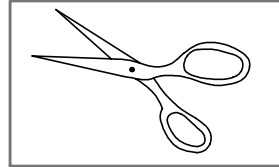
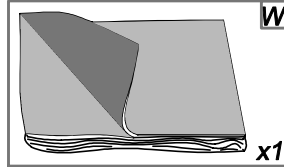
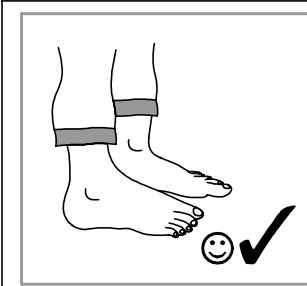

PL Lampa

GB Lamp

DE Lampe

FR Lampe

NL Lamp



PL Wycięcie otworu na lampę. Odrysuj miejsce na otwór lampy.

FR Dessinez l'endroit pour un trou pour la lampe. Coupez le trou pour la lampe.

GB Draw a place for lamp hole. Cut a hole for the lamp.

DE Zeichnen Sie einen Platz für das Lampenloch. Schneiden Sie ein Loch für die Lampe.

NL Teken de plek voor een gat voor de lamp. Snijd het gat voor de lamp.

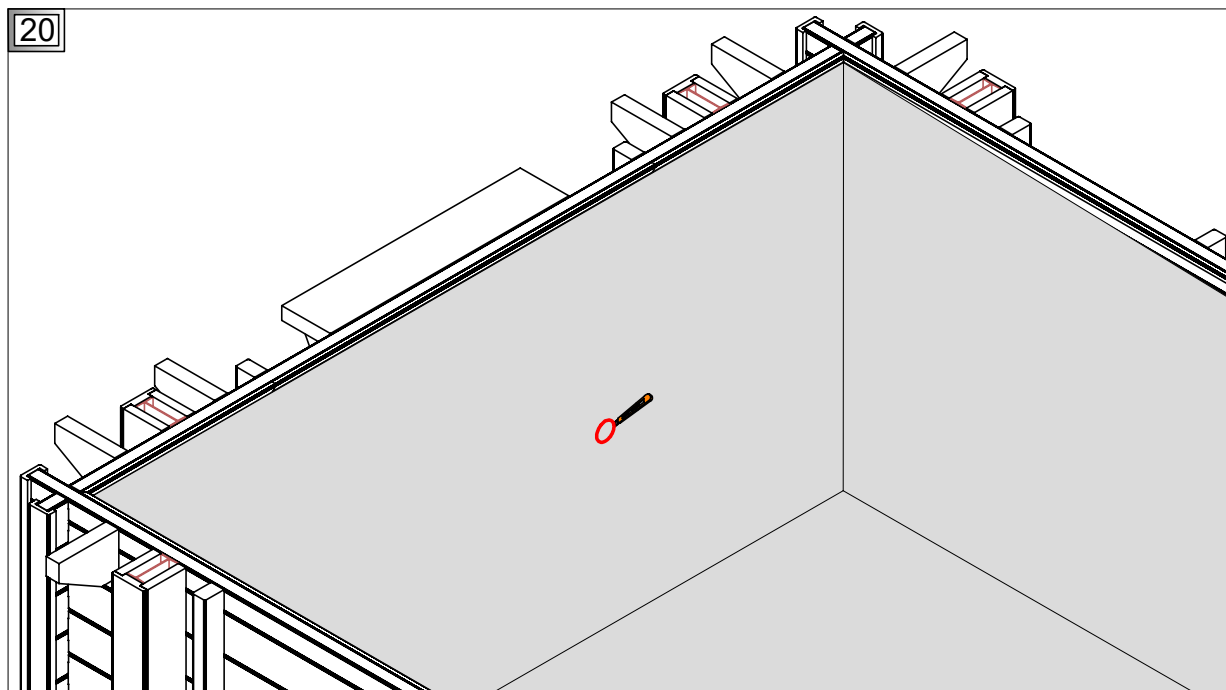
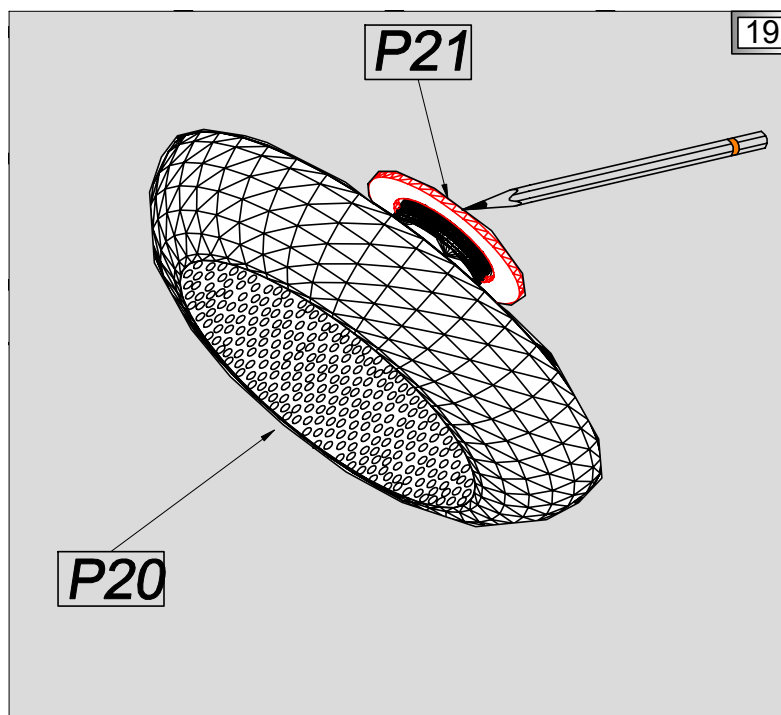
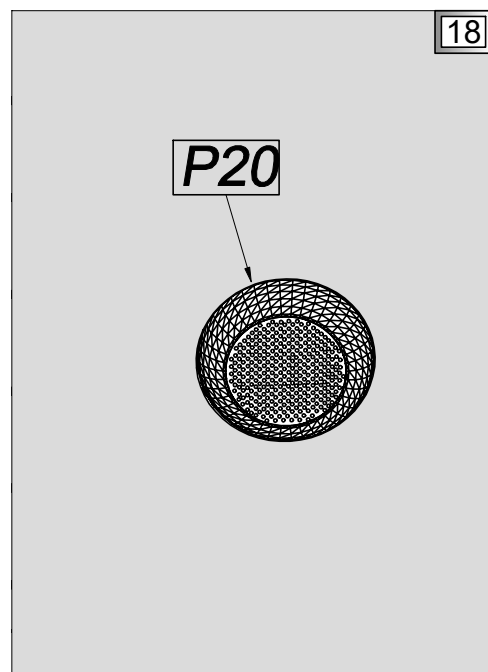
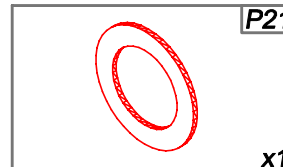
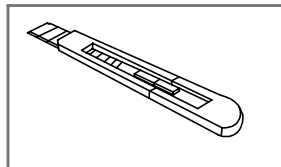
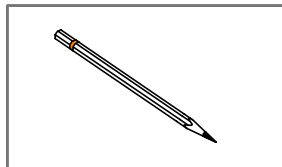
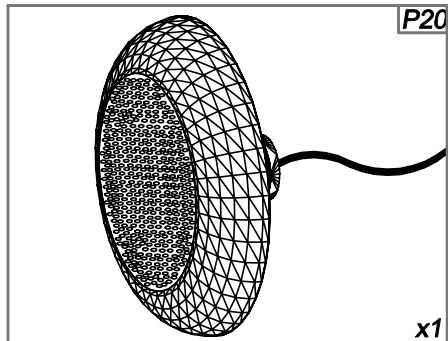

PL Skimmer

GB Skimmer

DE Skimmer

FR Skimmer

NL Skimmer



PL Zmontuj skimmer wg rysunków. Następnie zamontuj go w strukturze.

FR Montez le skimmer suivant les dessins. Ensuite fixez-le à la structure.

GB Install a skimmer according to the drawings. Next mount it to the structure.

DE Installieren Sie den Skimmer entsprechend der Zeichnungen. Als nächstes montieren Sie ihn an die Struktur.

NL Installeer de skimmer volgens de tekeningen. Monteer het vervolgens op de structuur.

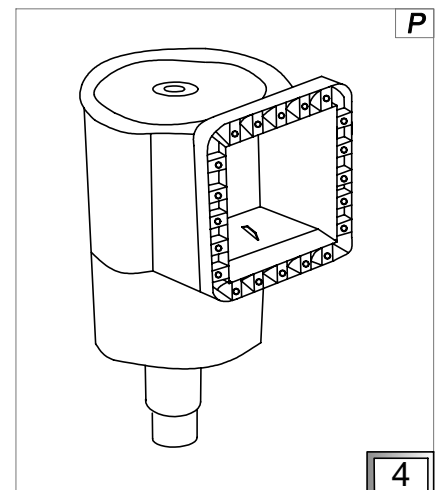
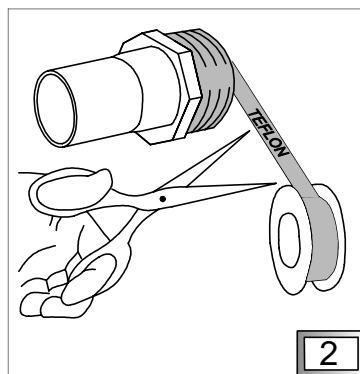
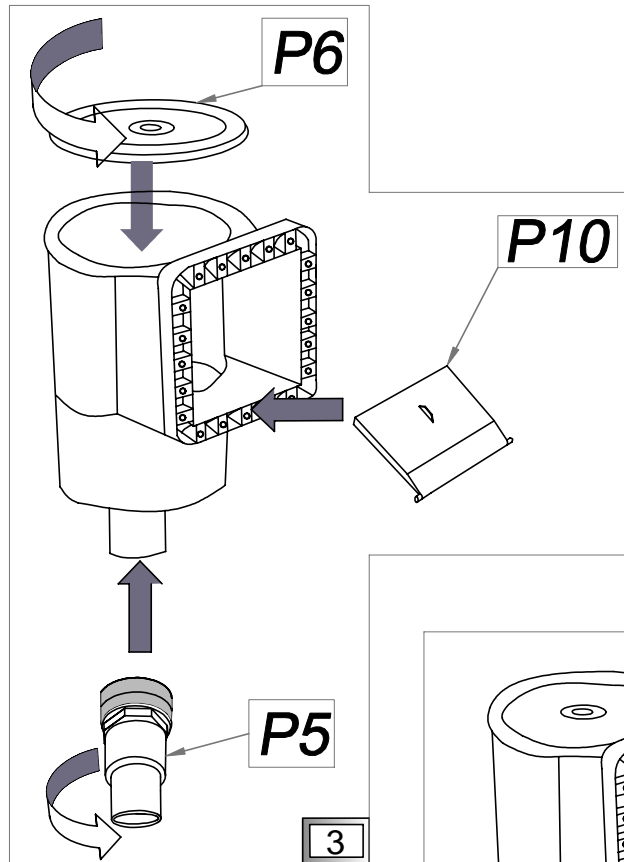
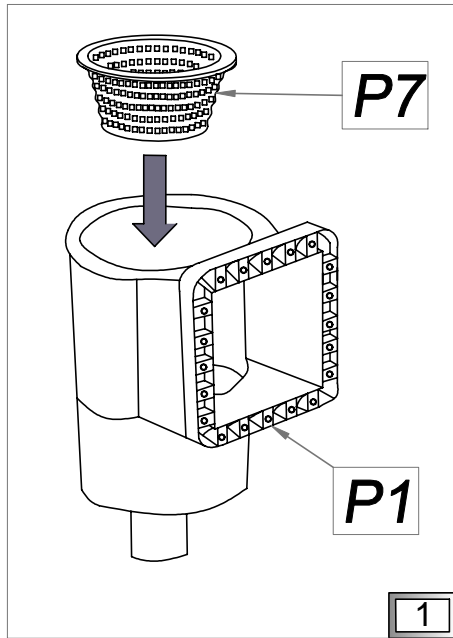
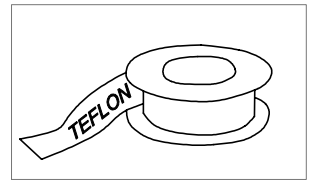
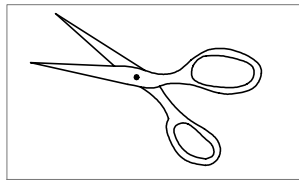
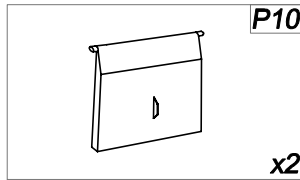
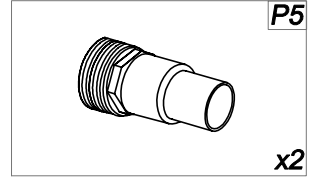
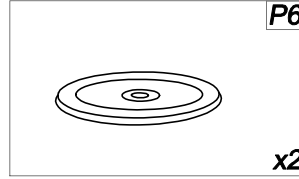
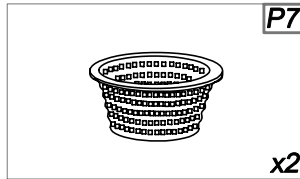
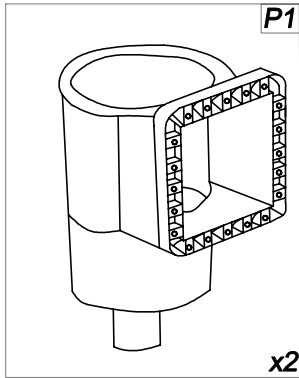

PL Skimmer

GB Skimmer

DE Skimmer

FR Skimmer

NL Skimmer



PL Zmontuj skimmer wg rysunków. Następnie zamontuj go w strukturze.

FR Montez le skimmer suivant les dessins. Ensuite fixez-le à la structure.

GB Install a skimmer according to the drawings. Next mount it to the structure.

DE Installieren Sie den Skimmer entsprechend der Zeichnungen. Als nächstes montieren Sie ihn an die Struktur.

NL Installeer de skimmer volgens de tekeningen. Monteer het vervolgens op de structuur.

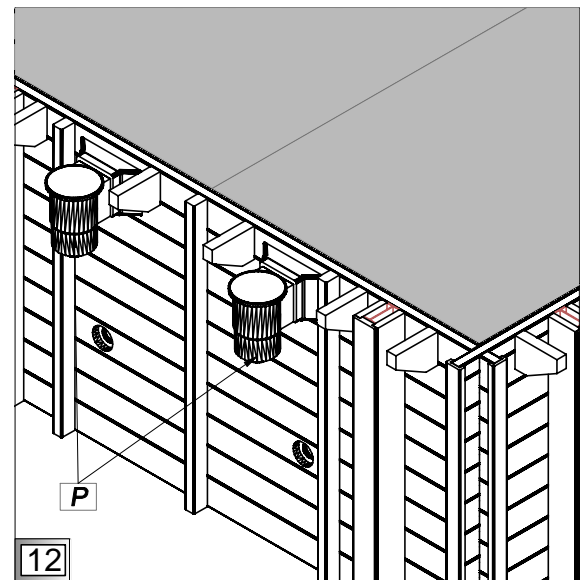
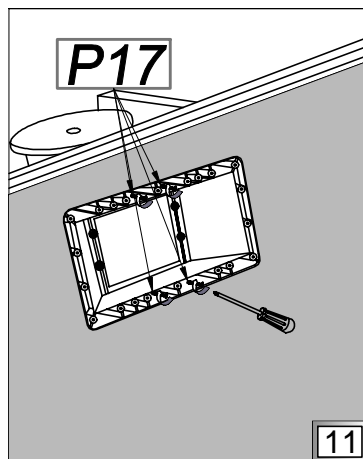
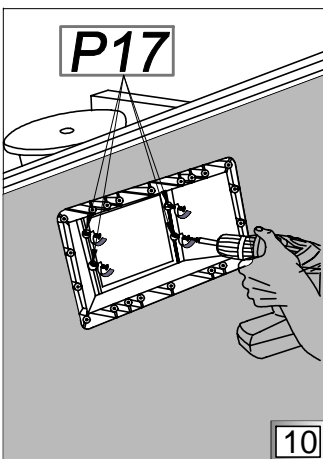
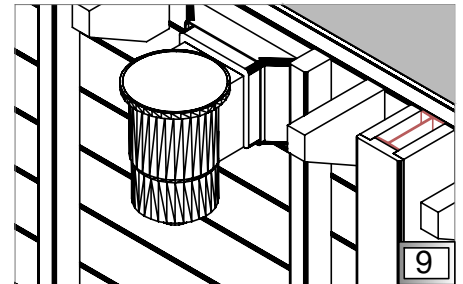
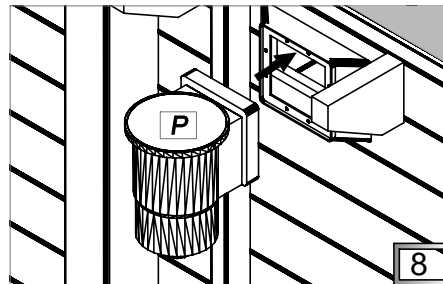
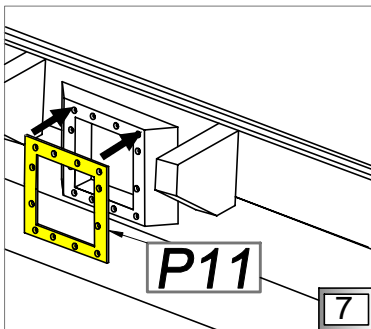
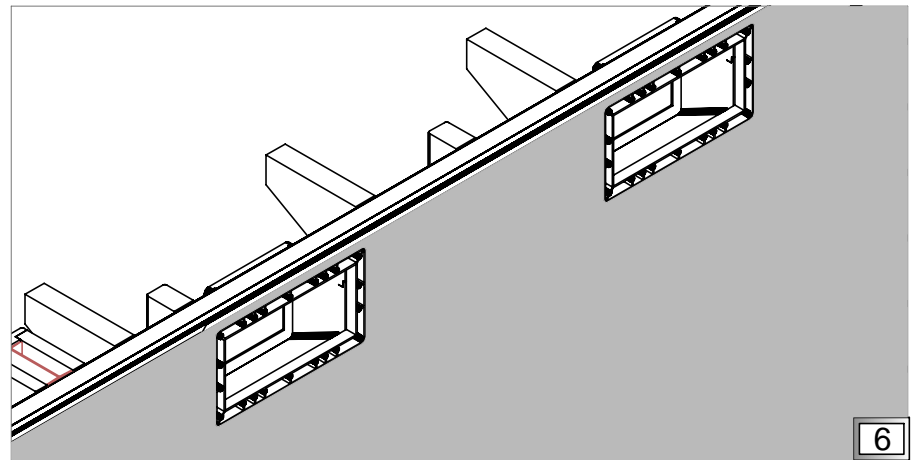
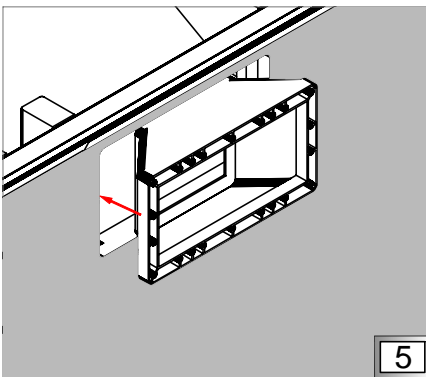
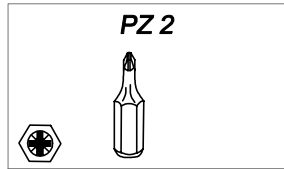
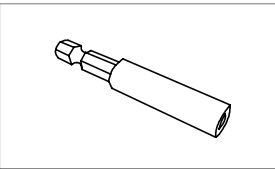
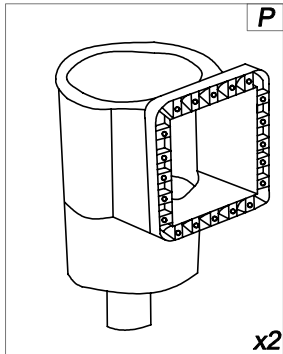
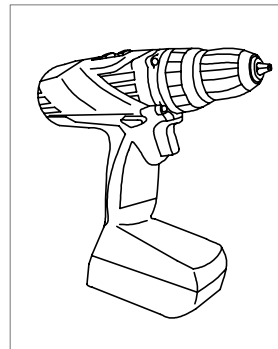
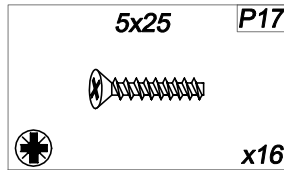
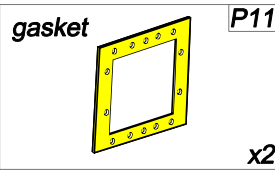
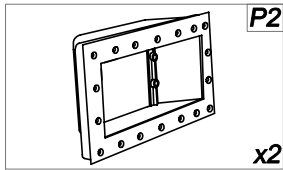

PL Skimmer

GB Skimmer

DE Skimmer

FR Skimmer

NL Skimmer



- PL** Powierzchnię dyfuzora (P2) okleić taśmą dwustronną, następnie przykleić uszczelkę (P3).
- FR** Mettez sur la surface du diffuseur (P2) une adhésif double face et collez un joint (P3).
- GB** Use double-sided tape on the surface of the diffuser (P2), stick gasket (P3) to it.
- DE** Die Diffusorfläche mit dem doppelseitigen Klebeband bekleben, anschließend die Dichtung ankleben.
- NL** Plak dubbelzijdige tape op het oppervlak van het rooster (P2) plak de pakking (P3) hier op.

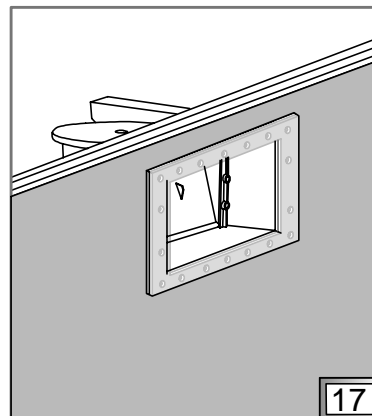
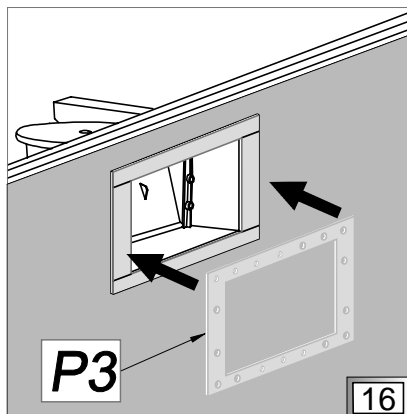
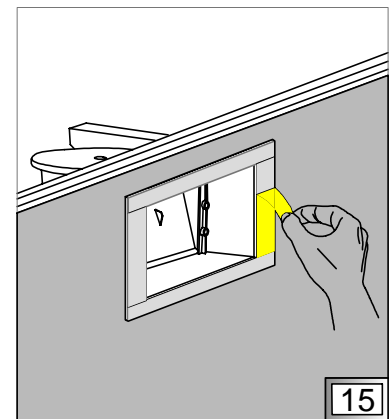
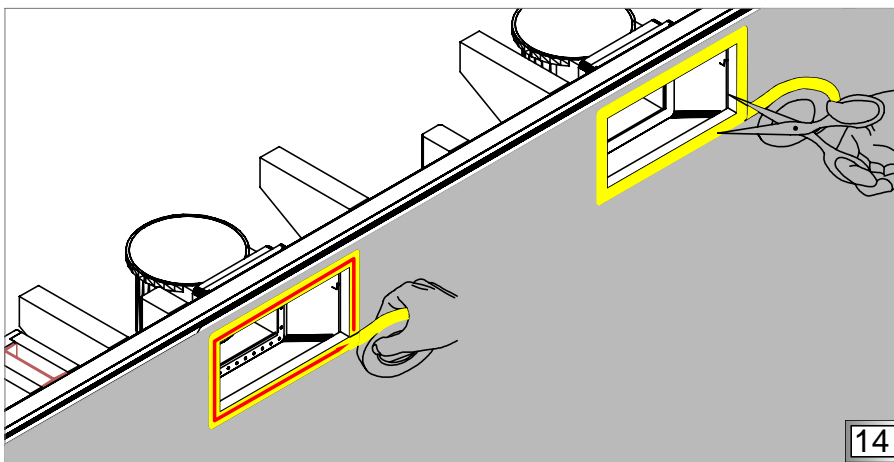
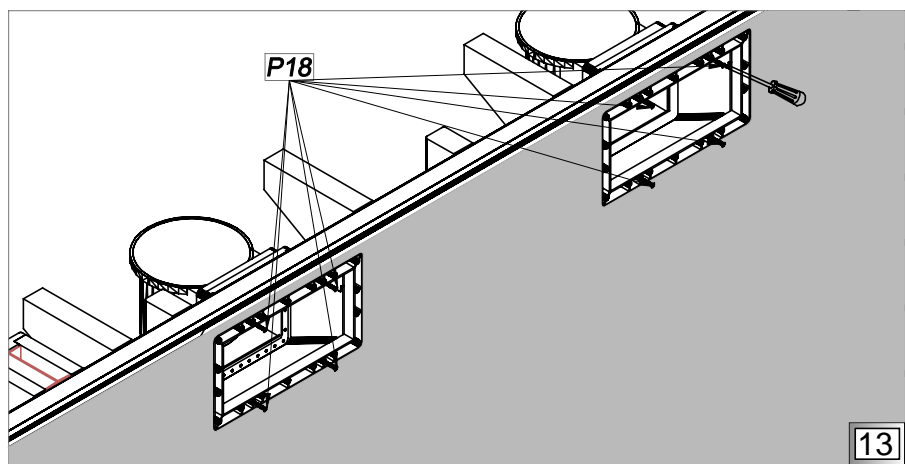
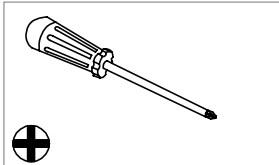
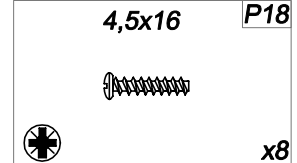
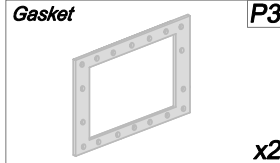
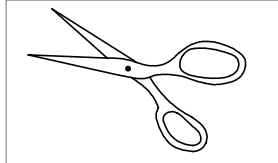

PL Liner

GB Liner

DE Futter

FR Liner

NL Voering



- PL** Montaż linera oraz stopera (LJ) w profilach (J).
- FR** Le montage du liner et de la bandelette (LJ) pour les profils d'accrochage (J).
- GB** Mounting the liner and liner lock (LJ) in PVC profiles (J).
- DE** Montage des Verschluss des Futters (LJ) der PVC-Profile (J).
- NL** De voeringvergrendeling (LJ) in PVC-profielen monteren (J).

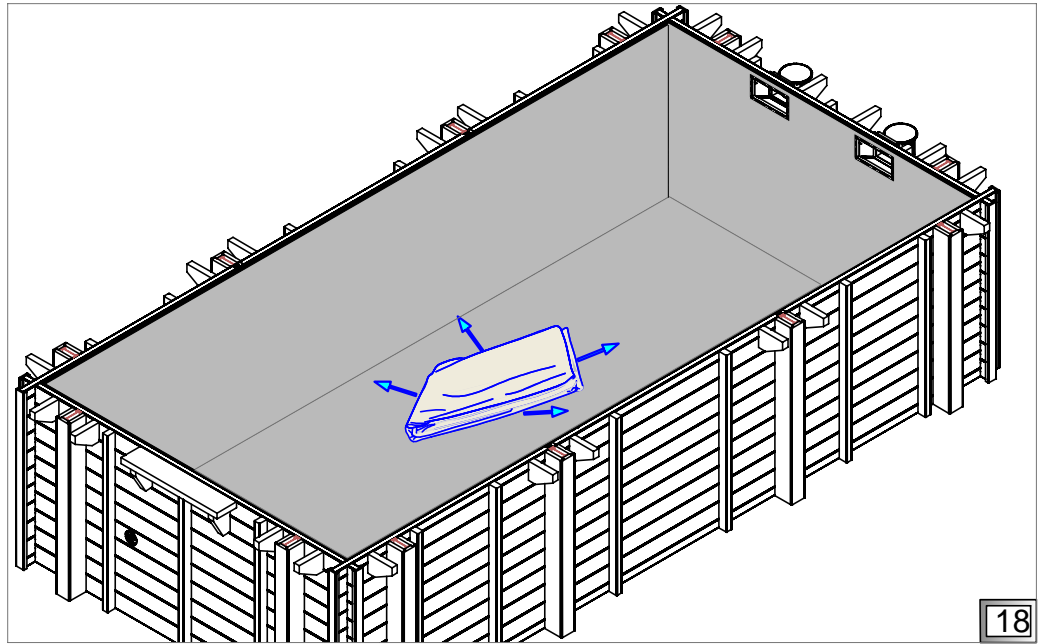
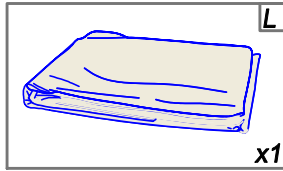
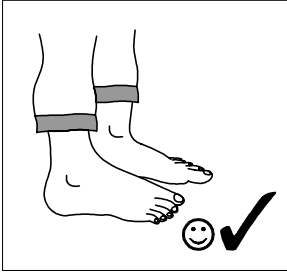

18

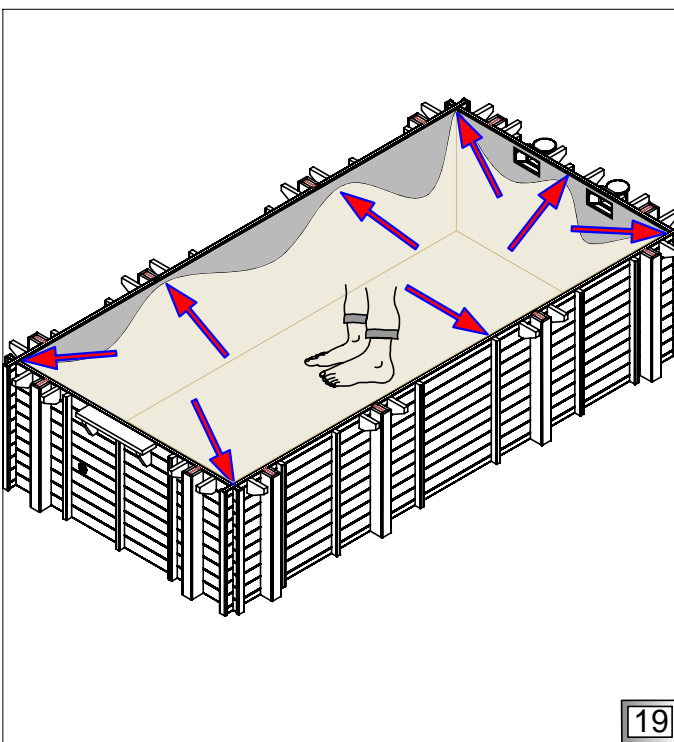
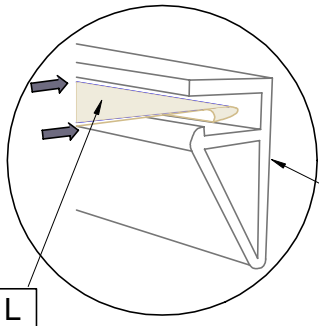

19

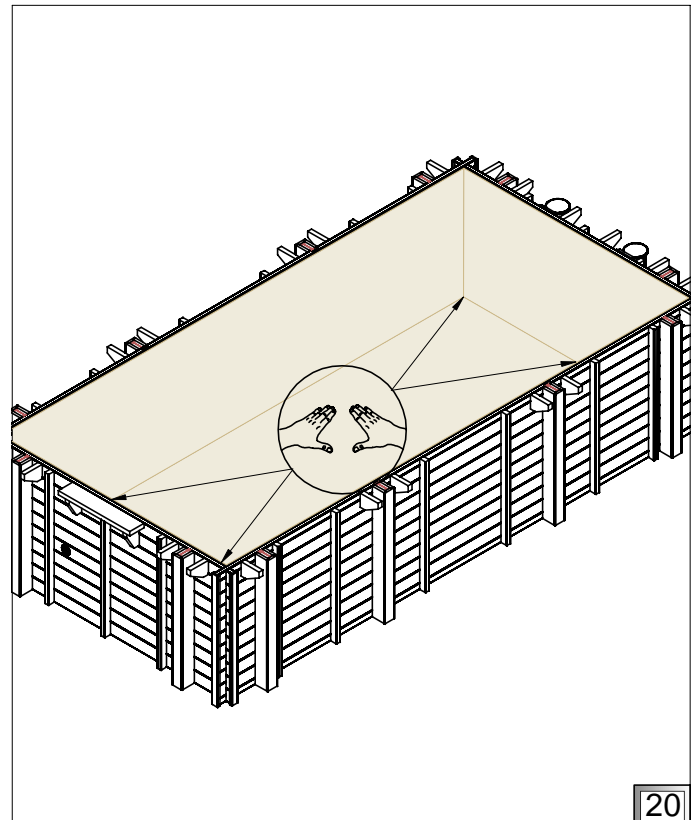

20

PL Liner

GB Liner

DE Futter

FR Liner

NL Voering



- PL** Montaż linera oraz stopera (LJ) w profilach (J).
- FR** Le montage du liner et de la bandelette (LJ) pour les profils d'accrochage (J).
- GB** Mounting the liner and liner lock (LJ) in PVC profiles (J).
- DE** Montage des Verschluss des Futters (LJ) der PVC-Profile (J).
- NL** De voeringvergrendeling (LJ) in PVC-profielen monteren (J).

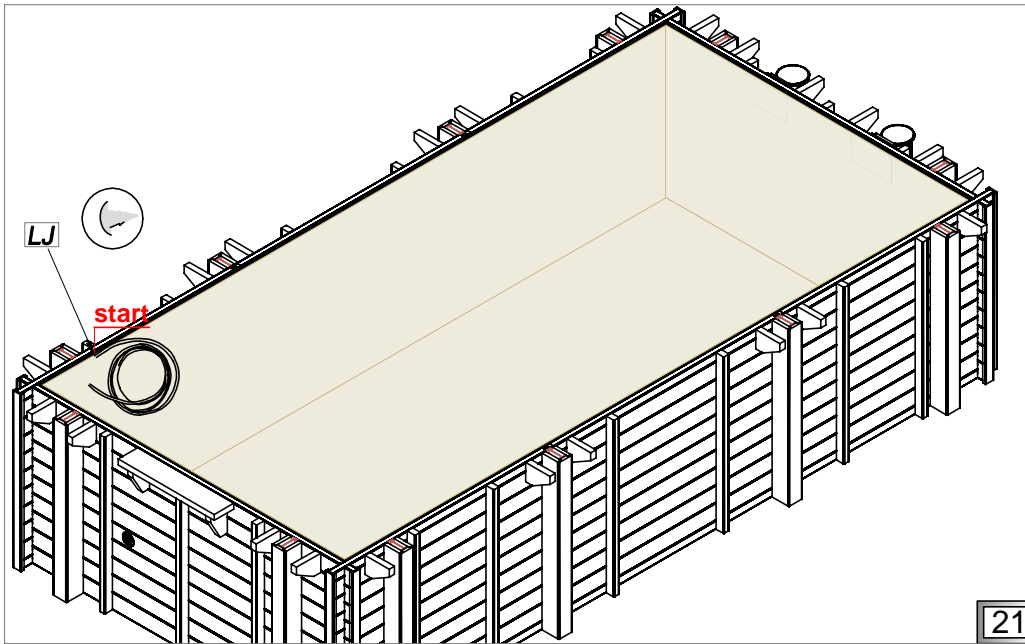
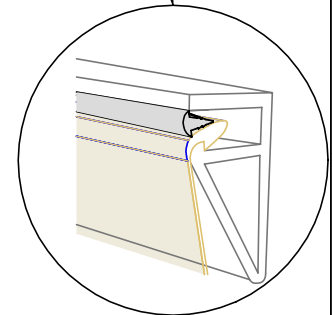
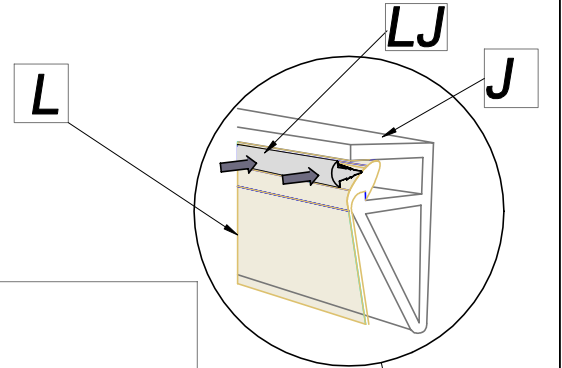
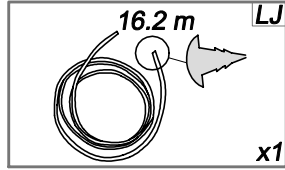
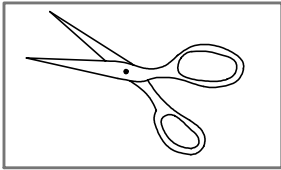

- PL** Wyrównaj sfaldowania po nalaniu wody.
- FR** Etalez les plis après avoir mis de l'eau.
- GB** Smooth all folds after pouring water.
- DE** Glätten Sie alle Falten nachdem Sie das Wasser eingelassen haben.
- NL** Maak alle vouwen glad na het vullen van water.

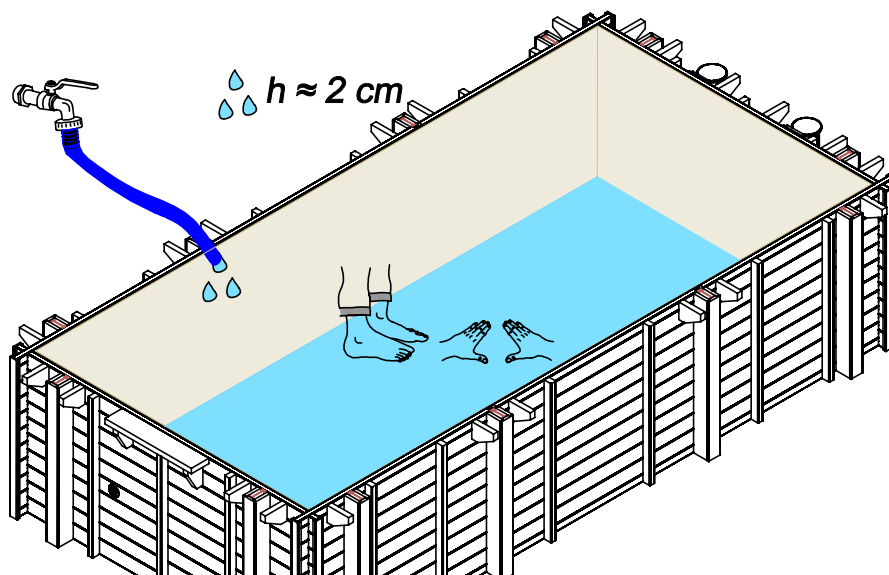
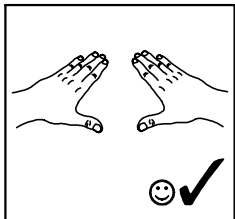

(PL) Dysze

(GB) Nozzles

(DE) Düsen

(FR) Les buses de refoulement

(NL) Jet straal



(PL) Po kolejnym nalaniu wody wyrównać sfaldowania. Wytnij otwór pod dyszę.

(FR) Après le versement de l'eau éliminez les plis. Faites les trous pour la buse de refoulement.

(GB) After pouring the water smooth all folds. Cut the hole for the nozzle.

(DE) Nachdem Sie das Wasser eingelassen haben, glätten Sie alle Falten. Schneiden Sie das Loch für die Düse heraus.

(NL) Strijk na het vullen van het water alle vouwen soepel. Snijd het gat voor de straalpijp.

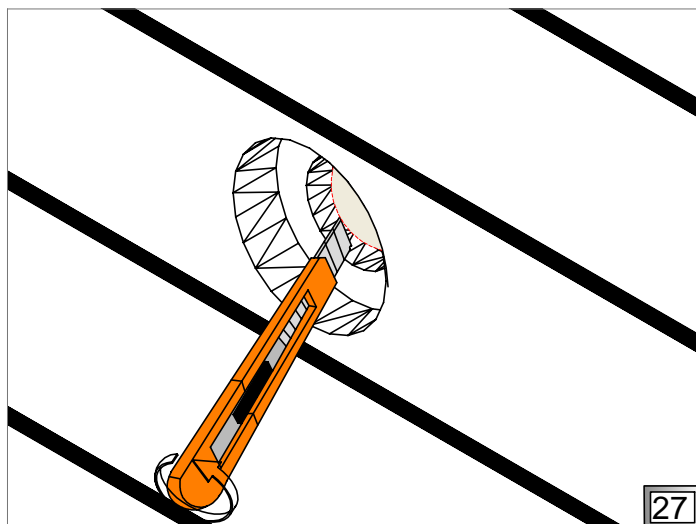
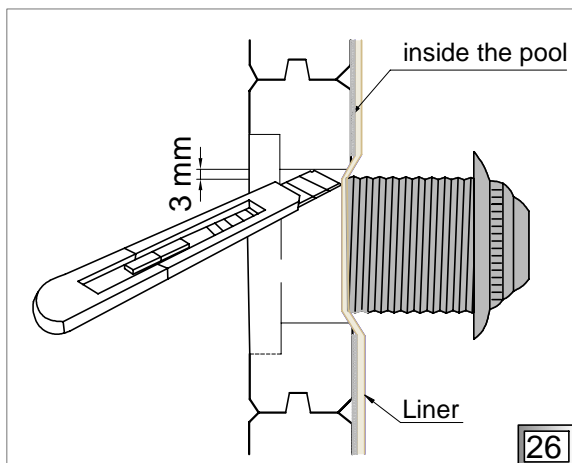
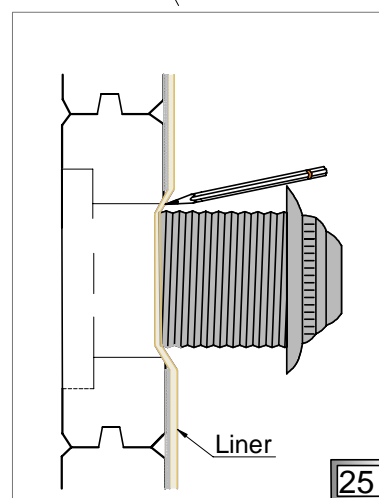
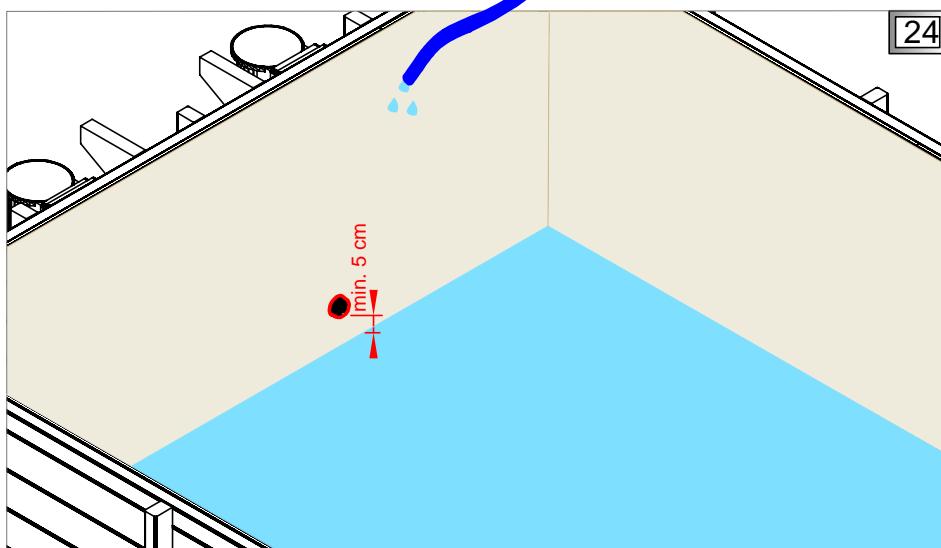
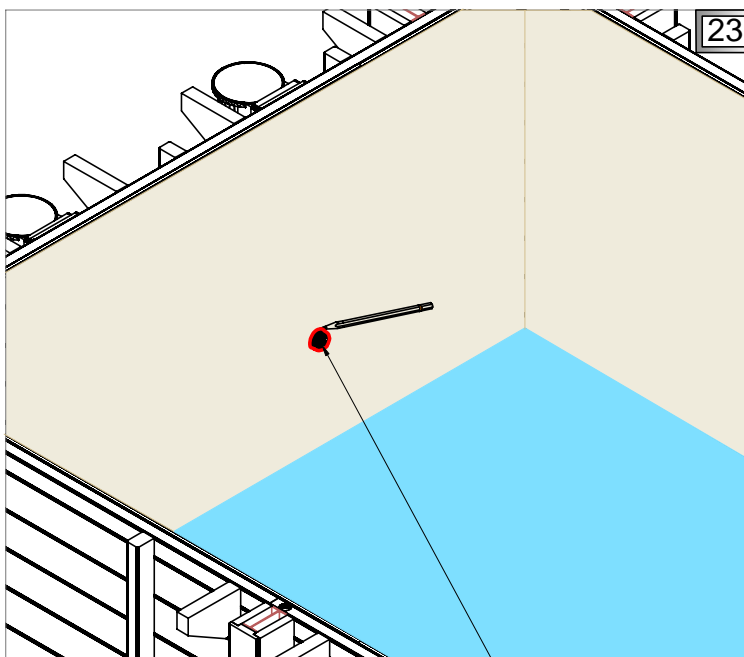
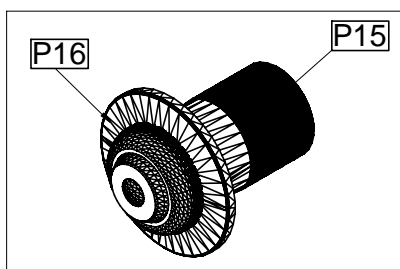
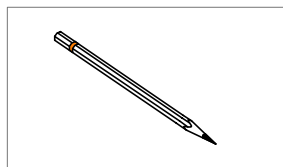
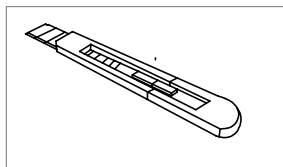
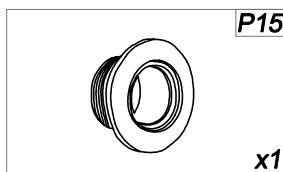
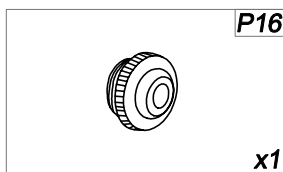

PL Dysze

GB Nozzles

DE Düsen

FR Les buses de refoulement

NL Jet straal



PL Uszczelki (P13) posmarować wazeliną od strony linera. Mocowanie dysz.

FR Étalez de la vaseline sur les joints (P13) du côté du liner. Le montage de la buse de refoulement.

GB Smear liner facing side of the gasket (P13) with vaseline. Installation of nozzles.

DE Beschmieren Sie die dem Futter (P13) zugewandte Seite der Dichtung mit Vaseline. Installation der Düsen.

NL Smeer de naar de voering (P13) gerichte kant van de pakking in met vaseline. Installatie van de jet straal.

gasket



P13

x4



P12

x2

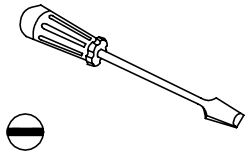

x3

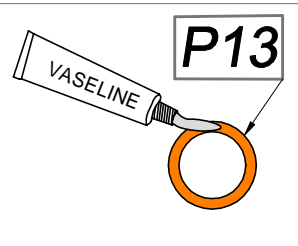

P13

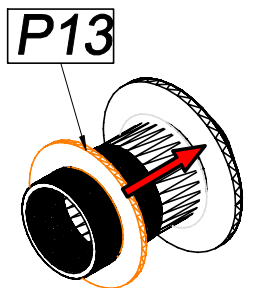

P13

28

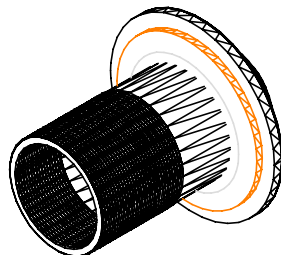

29

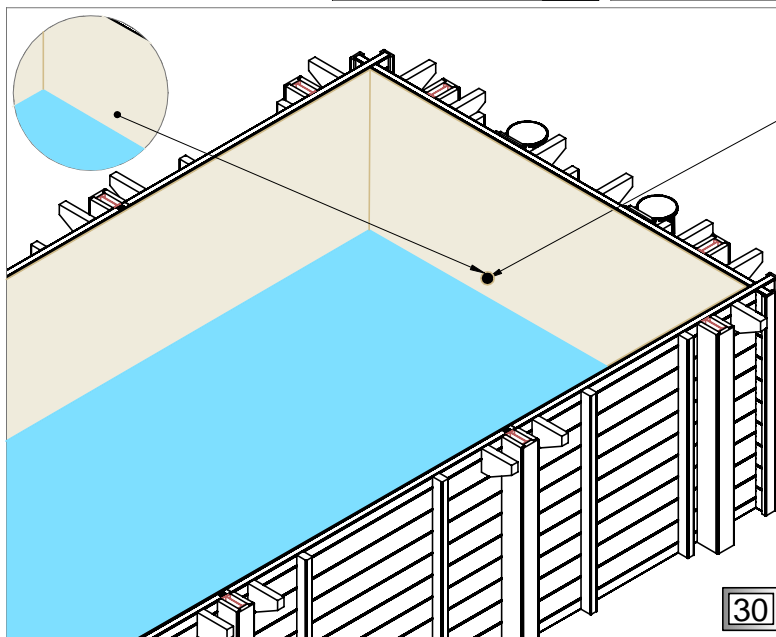
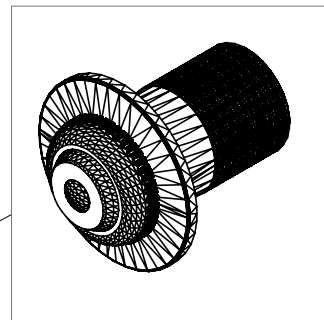

30

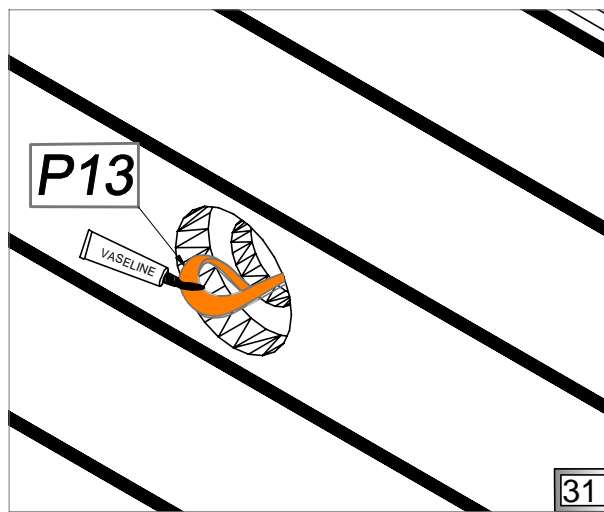

P13

31

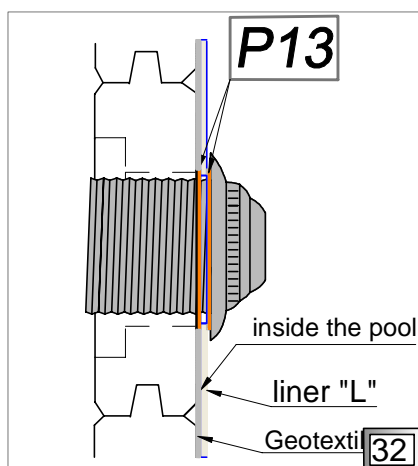

P13

inside the pool

liner "L"

Geotextil

32

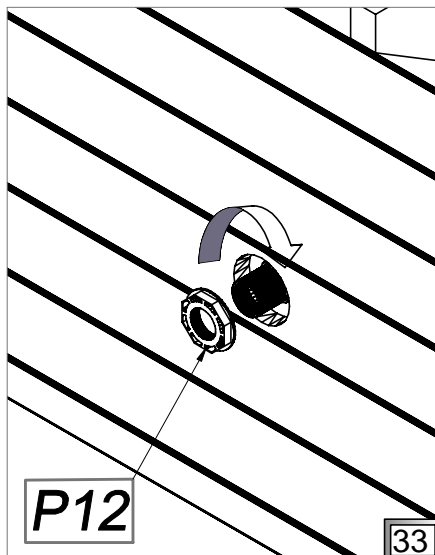

P12

33

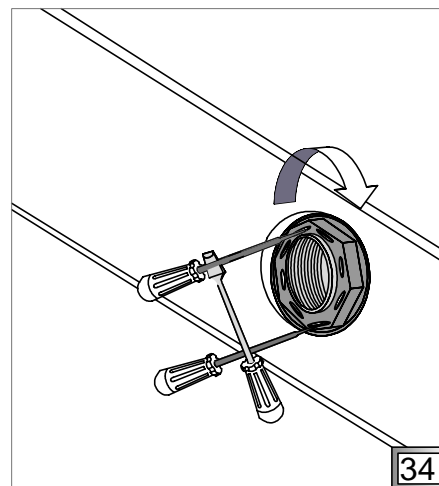

34

PL Dysze

GB Nozzles

DE Düsen

FR Les buses de refoulement

NL Jet straal



PL Pokryj gwint dysz taśmą teflonową.

FR Mettez le ruban teflon sur la partie filetée de la buse.

GB Cover thread of hose connector with teflon tape.

DE Decken Sie das Gewinde des Schlauchanschlusses mit Teflonband ab.

NL Dek de kabel van de slangconnector af met teflon-tape.

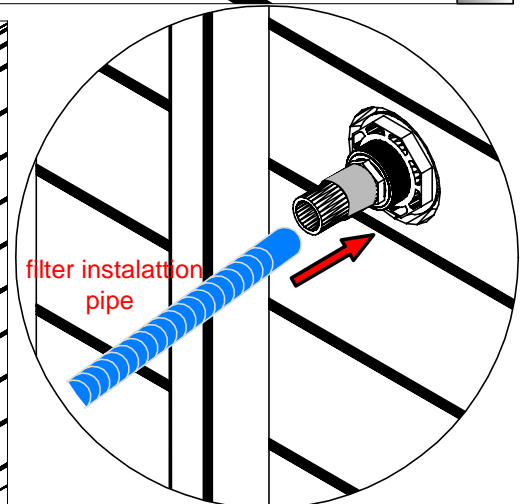
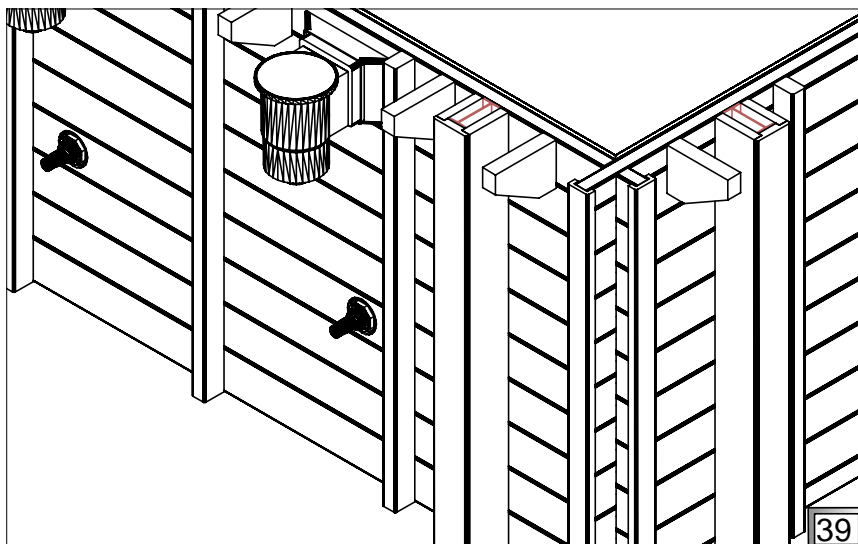
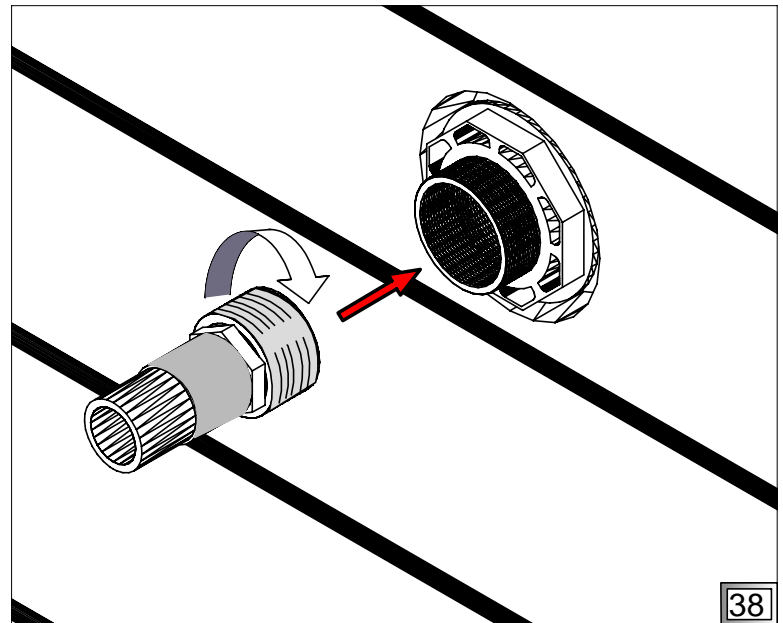
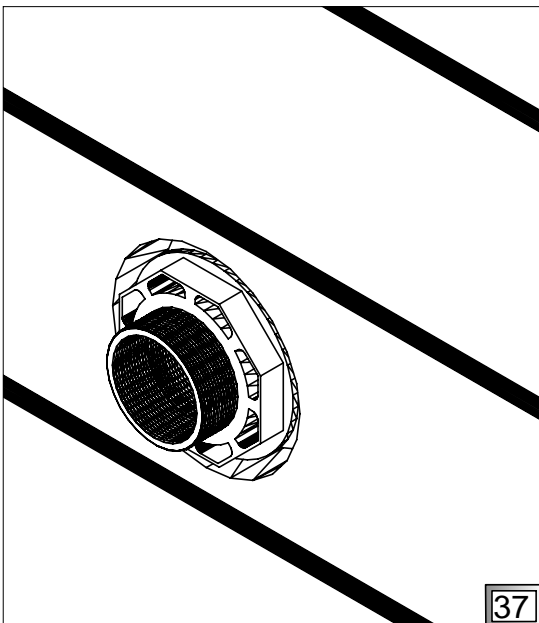
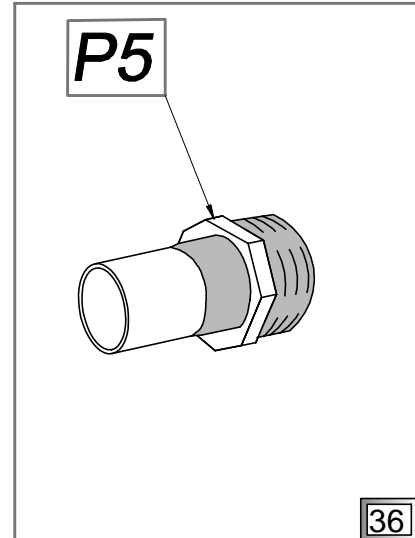
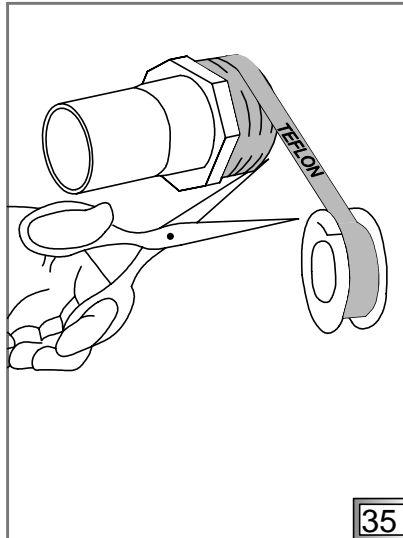
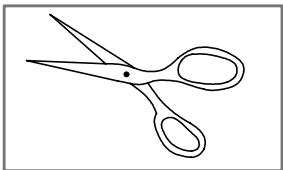
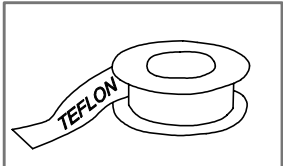
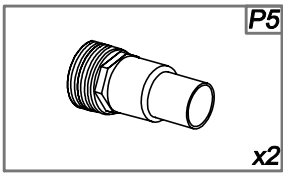

(PL) Lampa

(GB) Lamp

(DE) Lampe

(FR) Lampe

(NL) Lampe



(PL) Po kolejnym nalaniu wody wyrównać sfaldowania. Wytnij otwór pod lampę.

(FR) Après le versement de l'eau éliminez les plis. Faites les trous à la buse de lampe.

(GB) After pouring the water smooth all folds. Cut the hole for the lamp.

(DE) Nachdem Wasser wieder eingegossen wird, sind Faltungen zu ebnet. Öffnungen für die Lampe sind zu schneiden.

(NL) Na het gladstrijken van de plooien snij een gat voor de lamp.

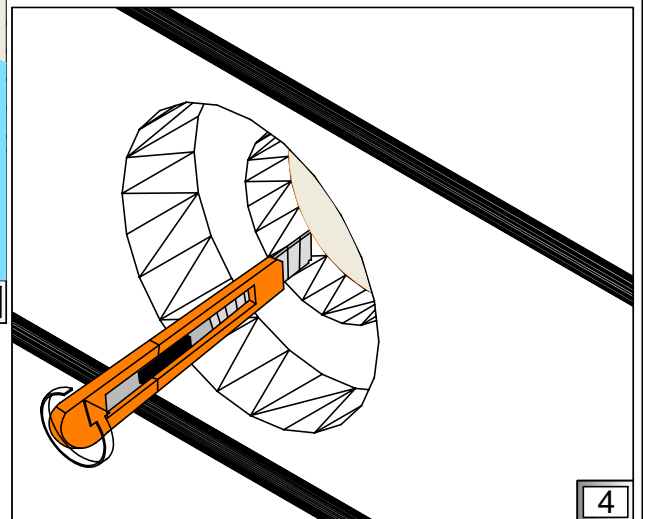
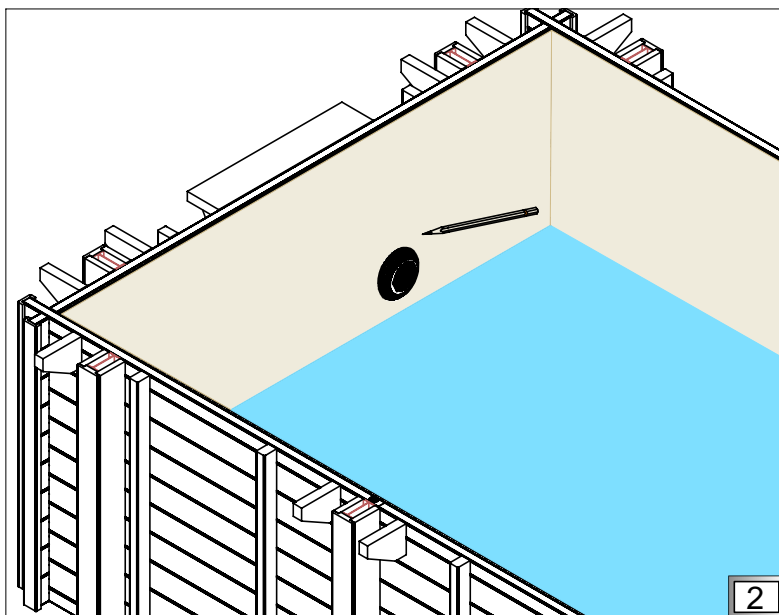
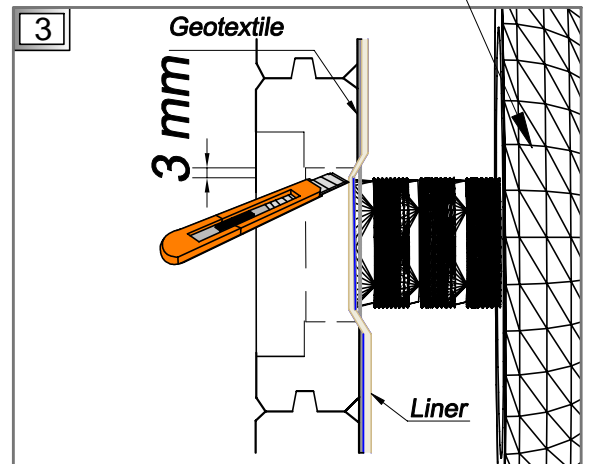
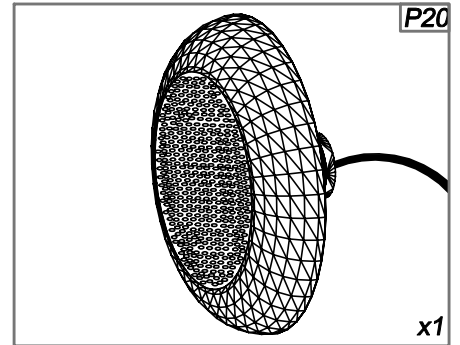
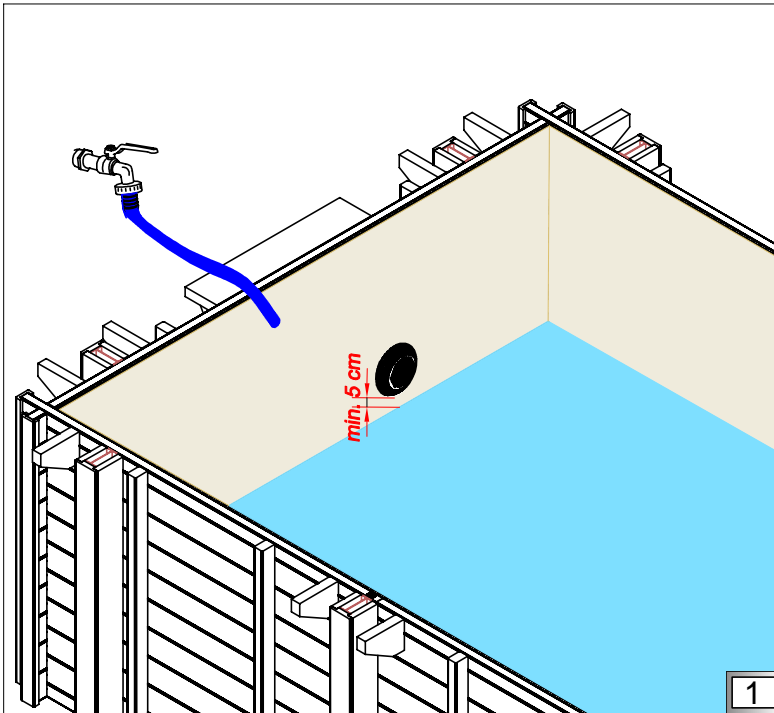
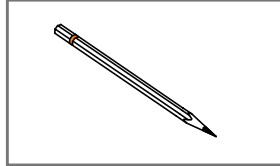
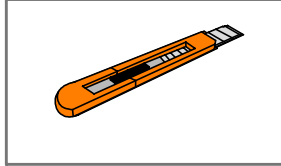

PL Lampa

GB Lamp

DE Lampe

FR Lampe

NL Lamp



- PL** Uszczelki (P21, P22) posmarować wazeliną od strony liner. Mocowanie lampy.
- FR** Etalez de la vaseline sur les joints (P21, P22) du côté de la liner. Le montage de la lampe.
- GB** Smear liner facing side of the gasket (P21, P22) with vaseline. Installation of lamp.
- DE** Die Dichtungen (P21, P22) sind von der Seite der Liner mit der Vaseline zu schmieren. Befestigung der Lampe.
- NL** Smeer de pakking (P21, P22) in met vaseline. Installatie van de lamp.

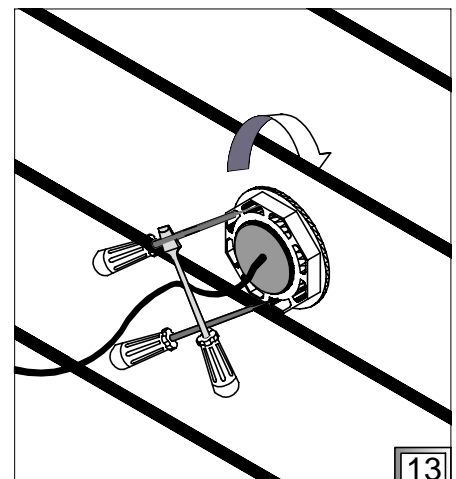
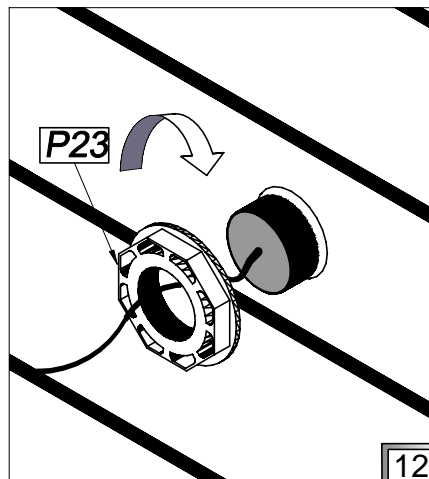
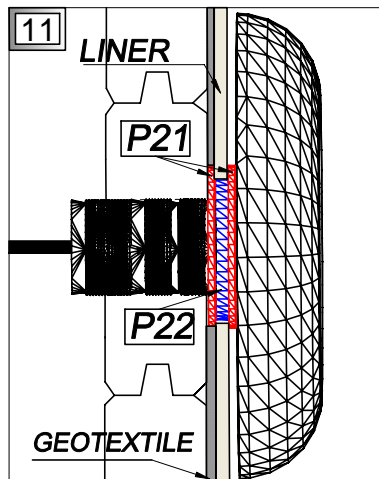
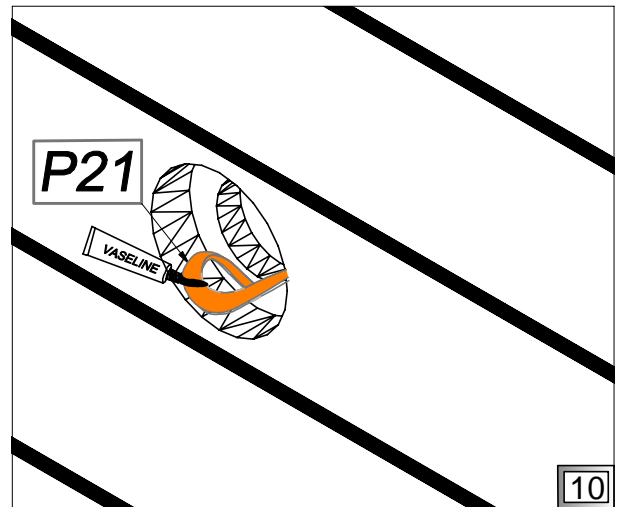
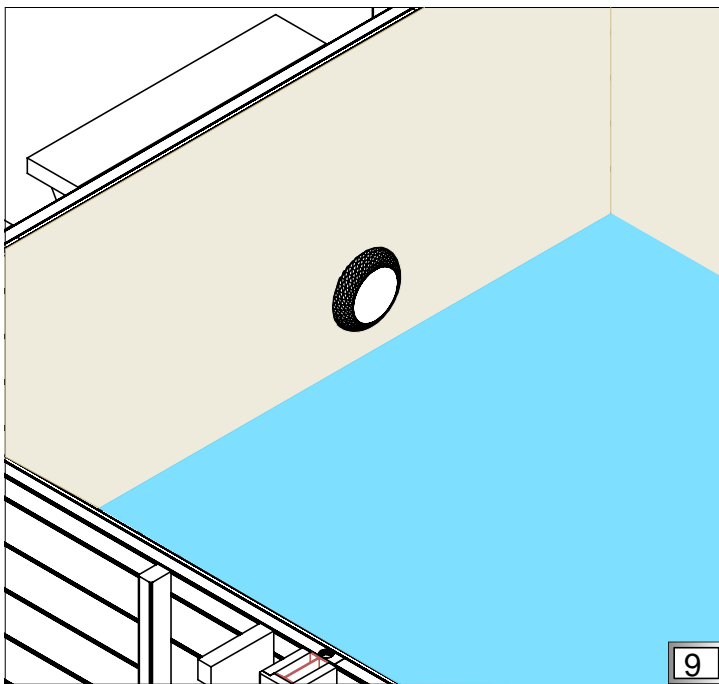
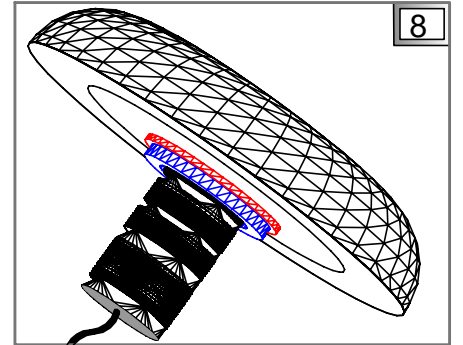
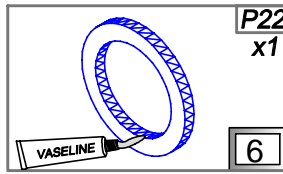
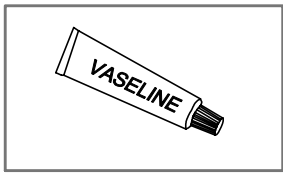
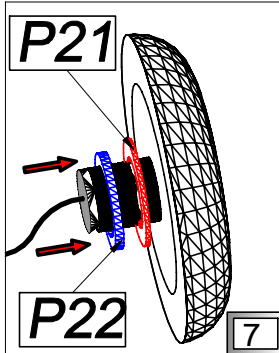
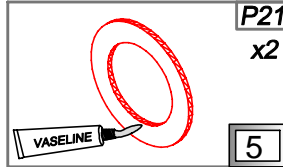
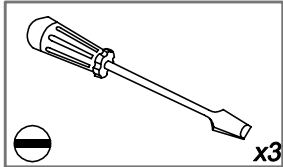
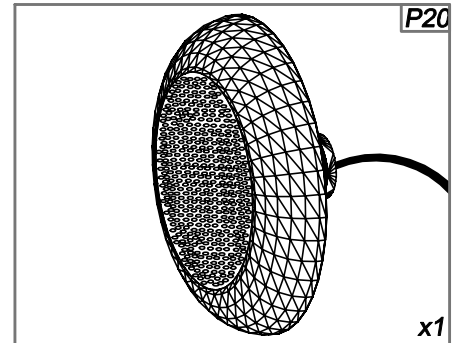
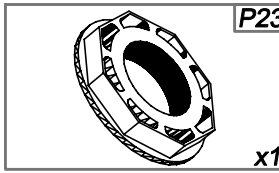
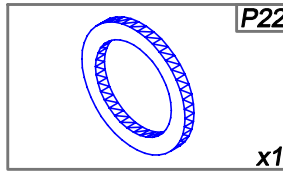
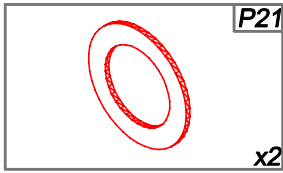

PL Lampa

GB Lamp

DE Lampe

FR Lampe

NL Lamp



- PL** Połącz przewód lampy z transformatorem.
- FR** Branchez le câble de la lampe au transformateur.
- GB** Connect the lamp wire to the transformer.
- DE** Verbindet das Lampenkabel an den Transformator.
- NL** Sluit de lamp aan op de transformator.

P24

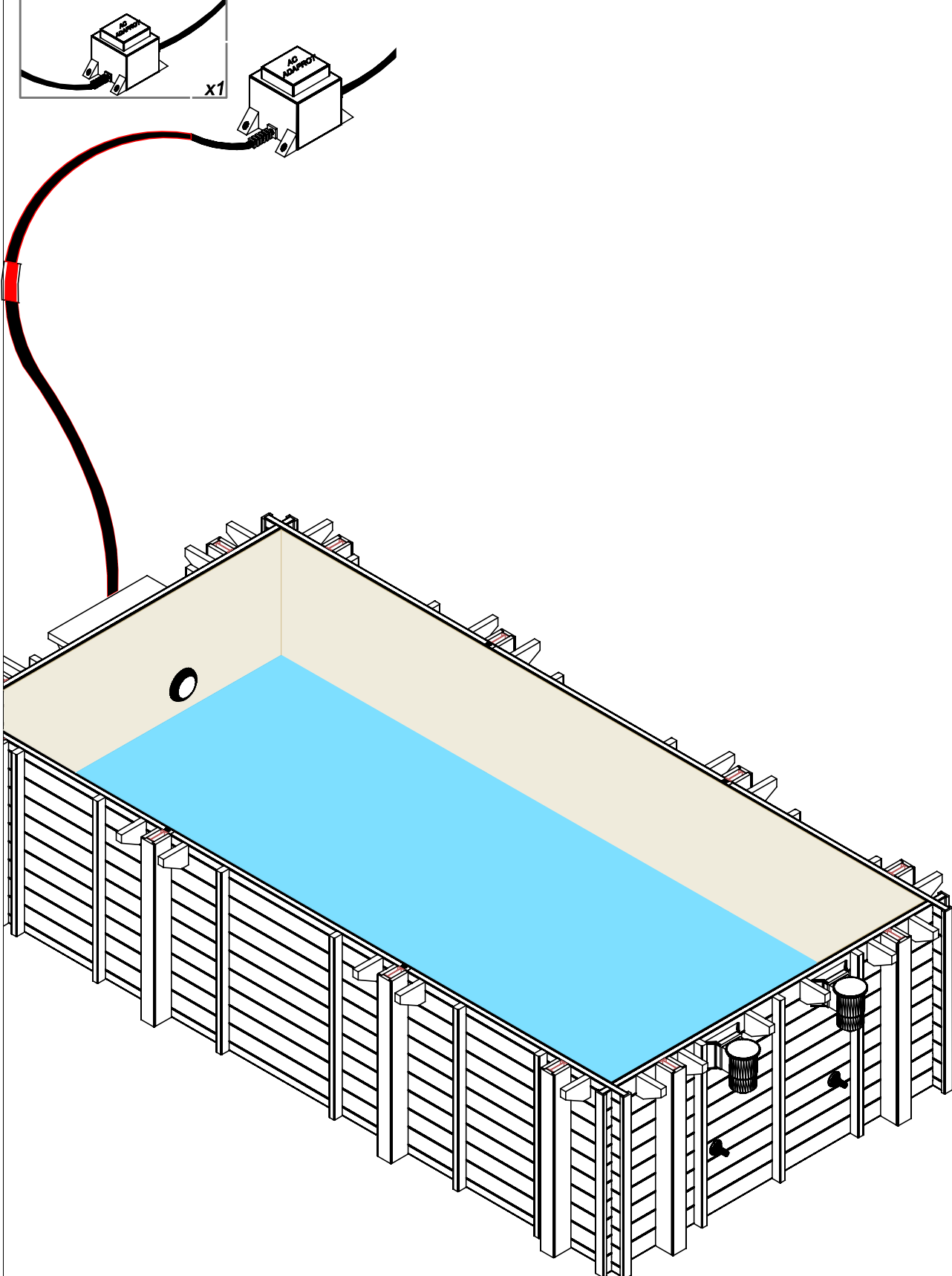

(A) Napelnianie wodą

(GB) Filling with water

(DE) Wasser einlassen

(FR) Le versement de l'eau

(NL) Vullen met water



(PL) Kontynuuj napełnianie wodą. Wytnij otwór w miejscu skimmera.

(FR) Continuez à mettre de l'eau. Coupez un trou pour le skimmer.

(GB) Keep pouring water. Cut a hole in the place of skimmer.

(DE) Lassen Sie weiterhin Wasser einlaufen. Schneiden Sie ein Loch an der Stelle des Skimmers.

(NL) Blijf water vullen. Snijd een gat in de plaats van de skimmer.

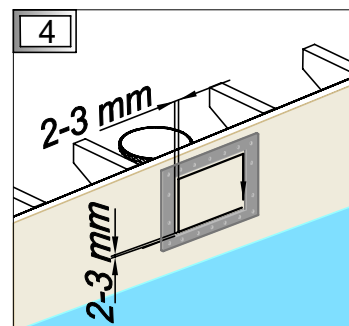
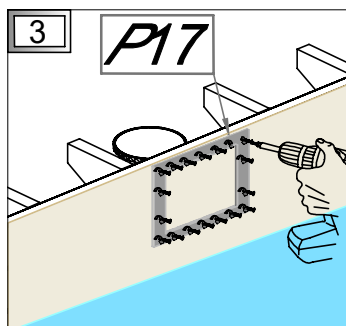
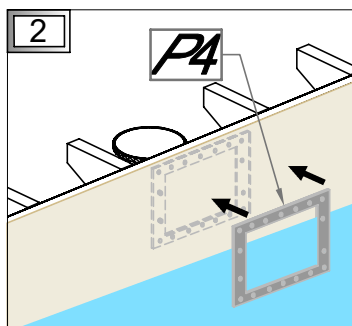
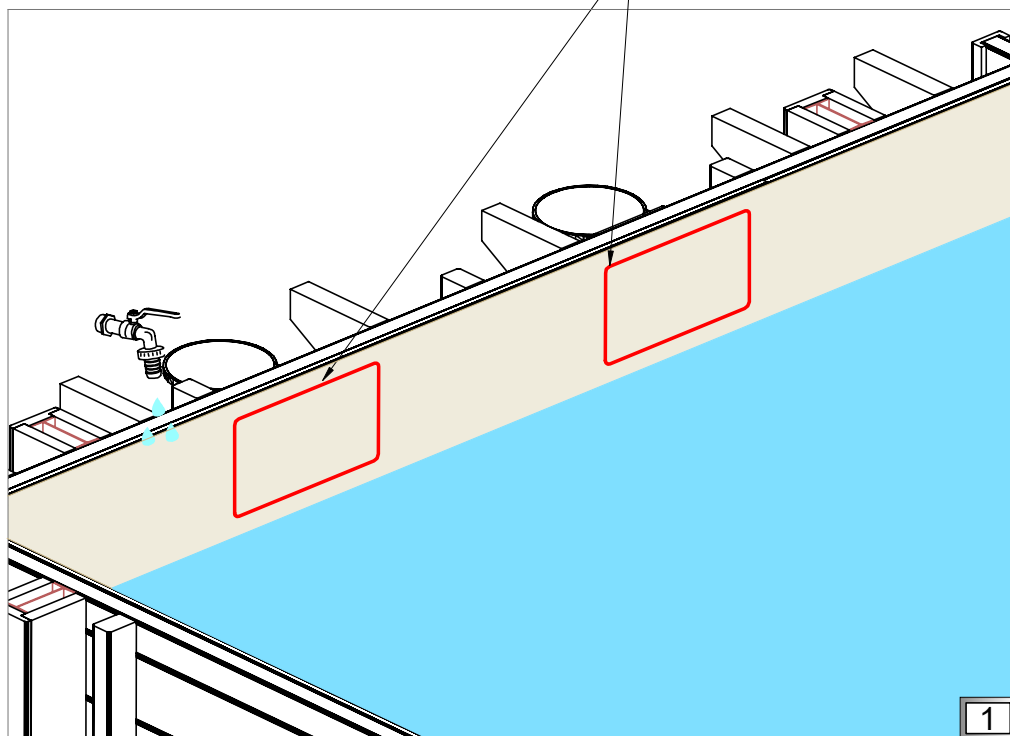
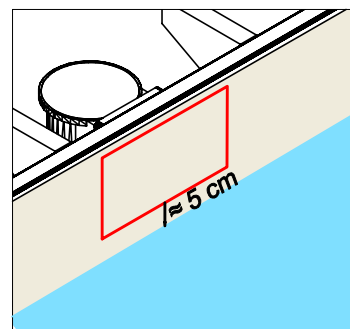
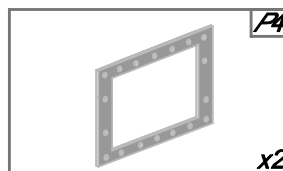
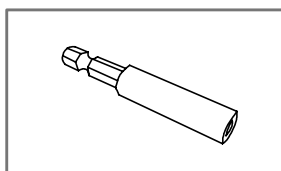
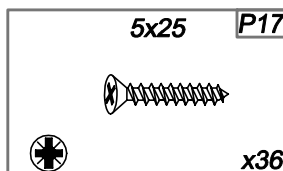
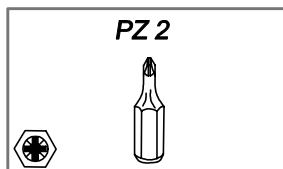
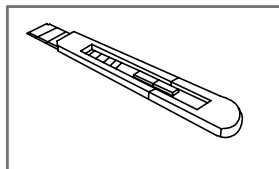
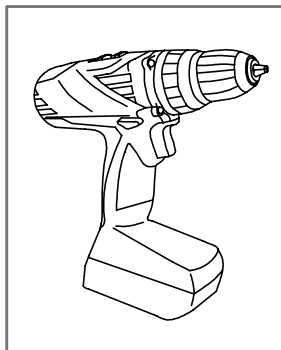
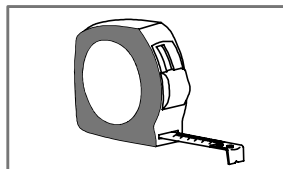

PL Napelnianie wodą

GB Filling with water

DE Wasser einlassen

FR Le versement de l'eau

NL Vullen met water



PL Usuń ramkę (P4). Zamocuj uszczelkę (P3), ramkę (P4), maskownicę (P4a).

FR Enlevez le cadre (P4). Fixez le joint (P3), le cadre (P4), le cache (P4a).

GB Remove a frame (P4). Install gasket (P3), frame (P4), masking frame (P4a).

DE Entfernen Sie einen Rahmen (P4). Installieren Sie Dichtung (P3), Rahmen (P4), Abdeckrahmen (P4a).

NL Verwijder een kader (P4). Installeer pakking (P3), frame (P4), skimmer frame (P4a).

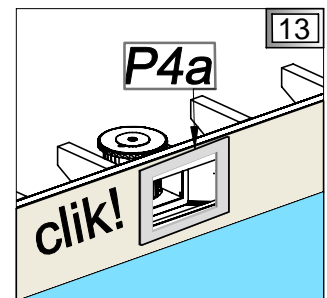
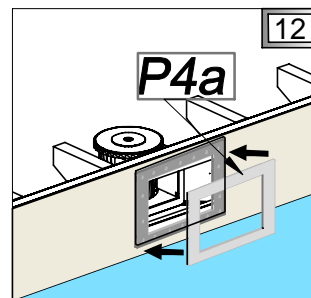
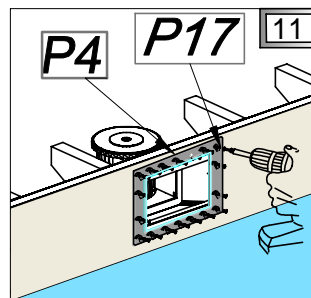
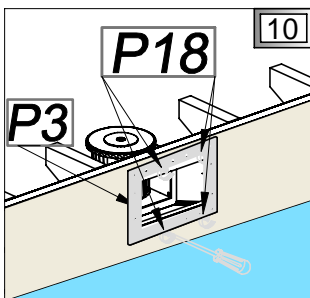
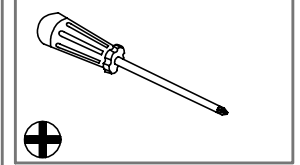
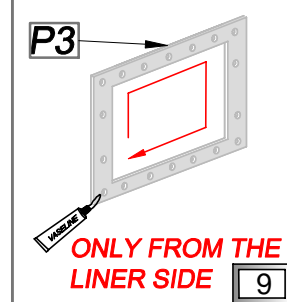
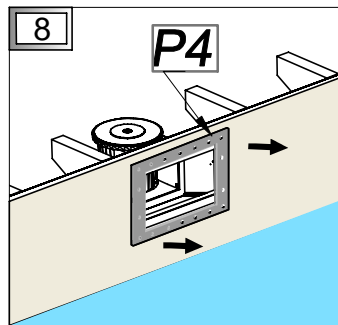
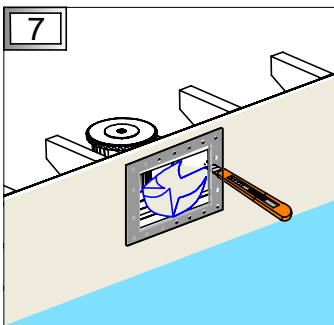
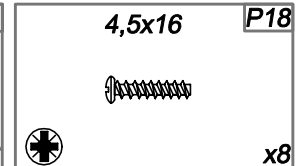
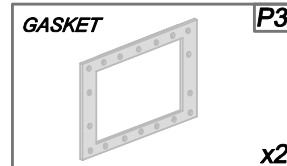
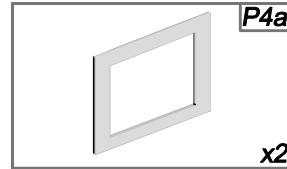
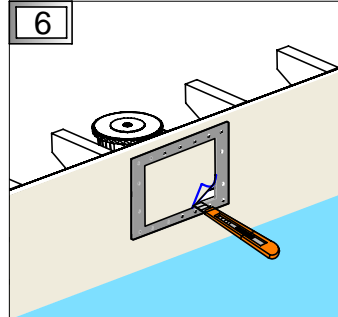
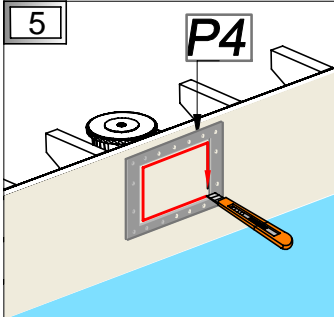

≈1/2 h
skimmer

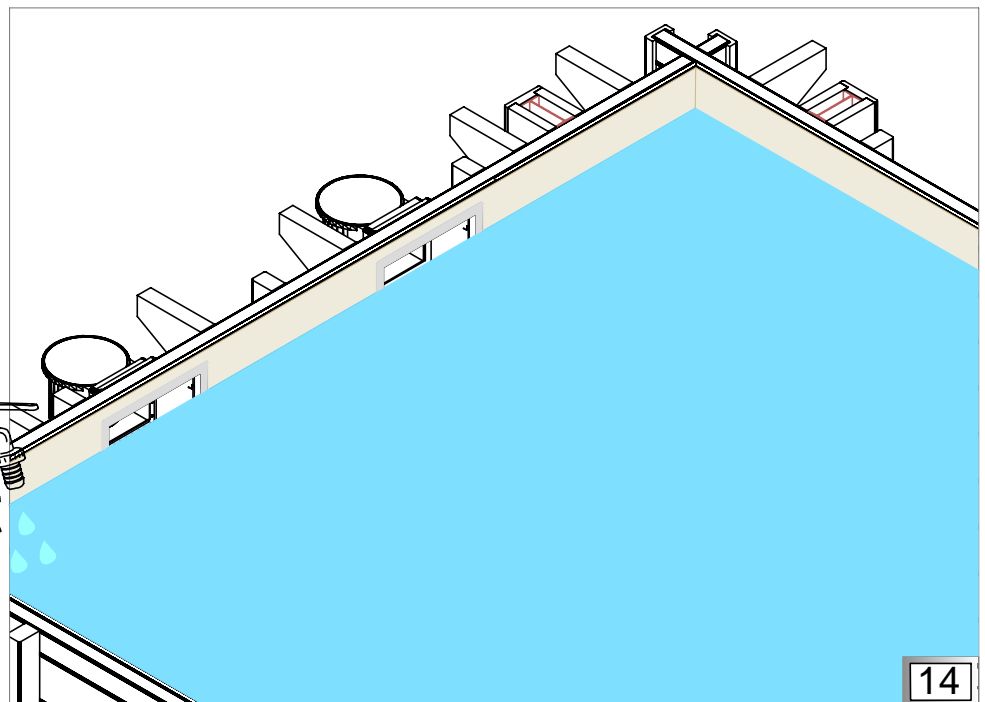

PL Struktura drewniana

GB Wooden structure

DE Holzstruktur

FR La structure bois

NL Houten structuur



PL Rozmieszczenie łączników tarasu (TC). Zwróć uwagę na ułożenie otworów.

FR Disposition des connecteurs de terrasse (TC). Faites attention aux trous d'installation.

GB Arrangement of terrace connectors (TC). Pay attention to the installation holes.

DE Anordnung der Terrassenanschlüsse (TC). Achten Sie auf die Installationslöcher.

NL Plaatsing van terrasaansluitingen (TC). Let op de installatiegaten.

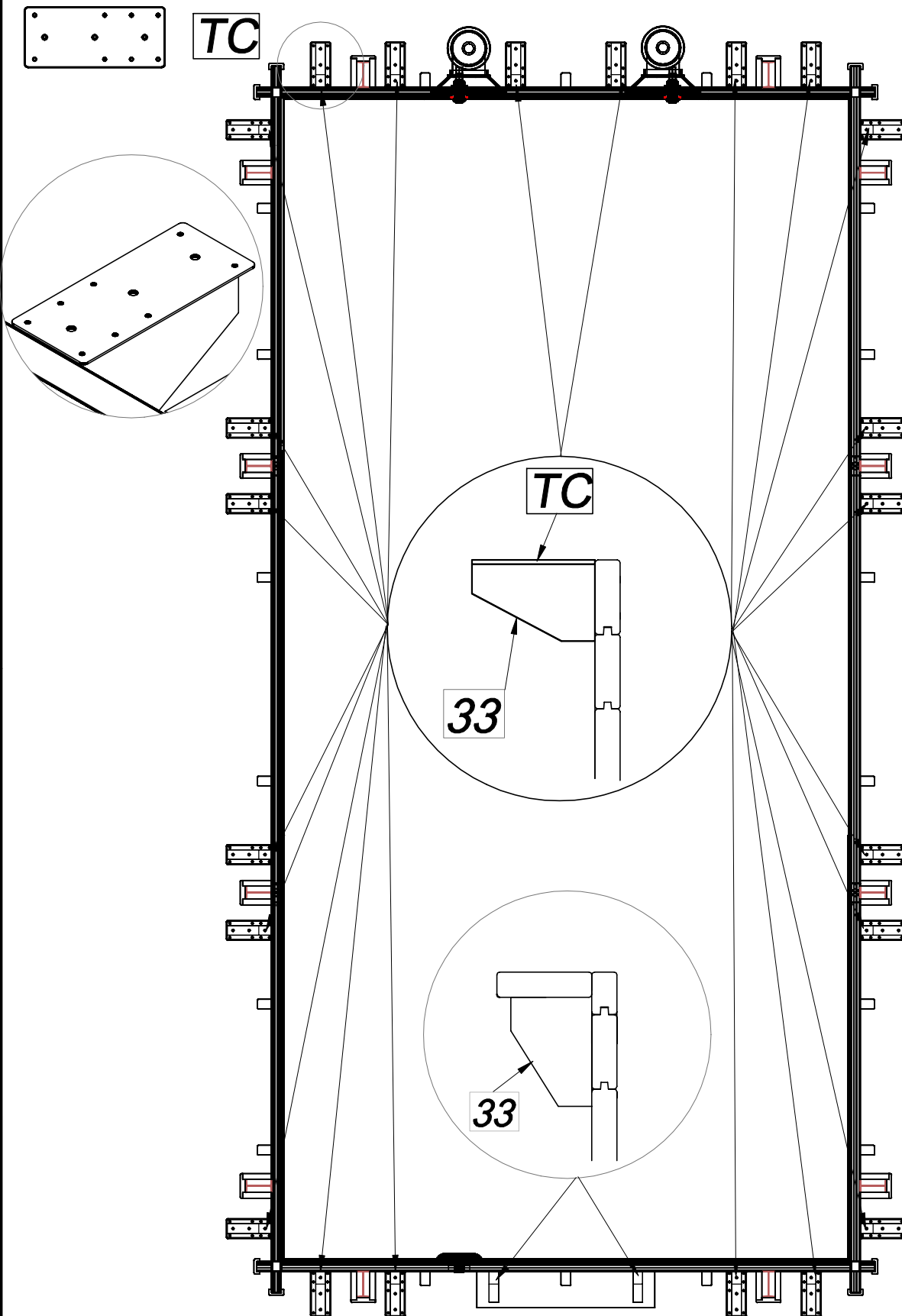

PL Struktura drewniana

GB Wooden structure

DE Holzstruktur

FR La structure bois

NL Houten structuur



PL Montaż łączników tarasu (TC) do konsol (33).

FR Montez les connecteurs de terrasse (TC) sur les consoles (33).

GB Mount terrace connectors (TC) to consoles (33).

DE Montieren Sie die Terrassenanschlüsse (TC) an den Konsolen (33).

NL Monteer terrasconnectoren (TC) op consoles (33).

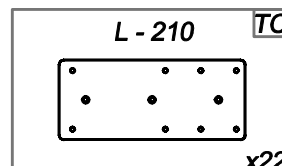
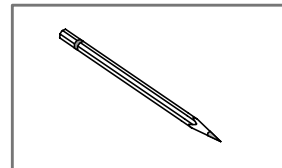
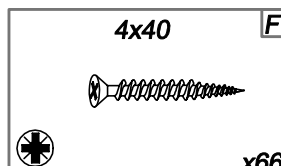
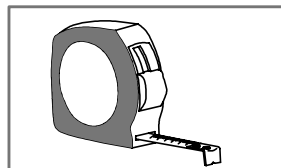
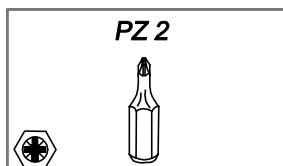
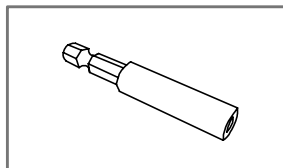
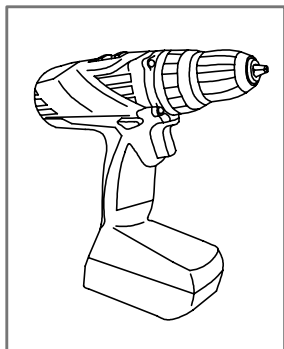

x66

x22

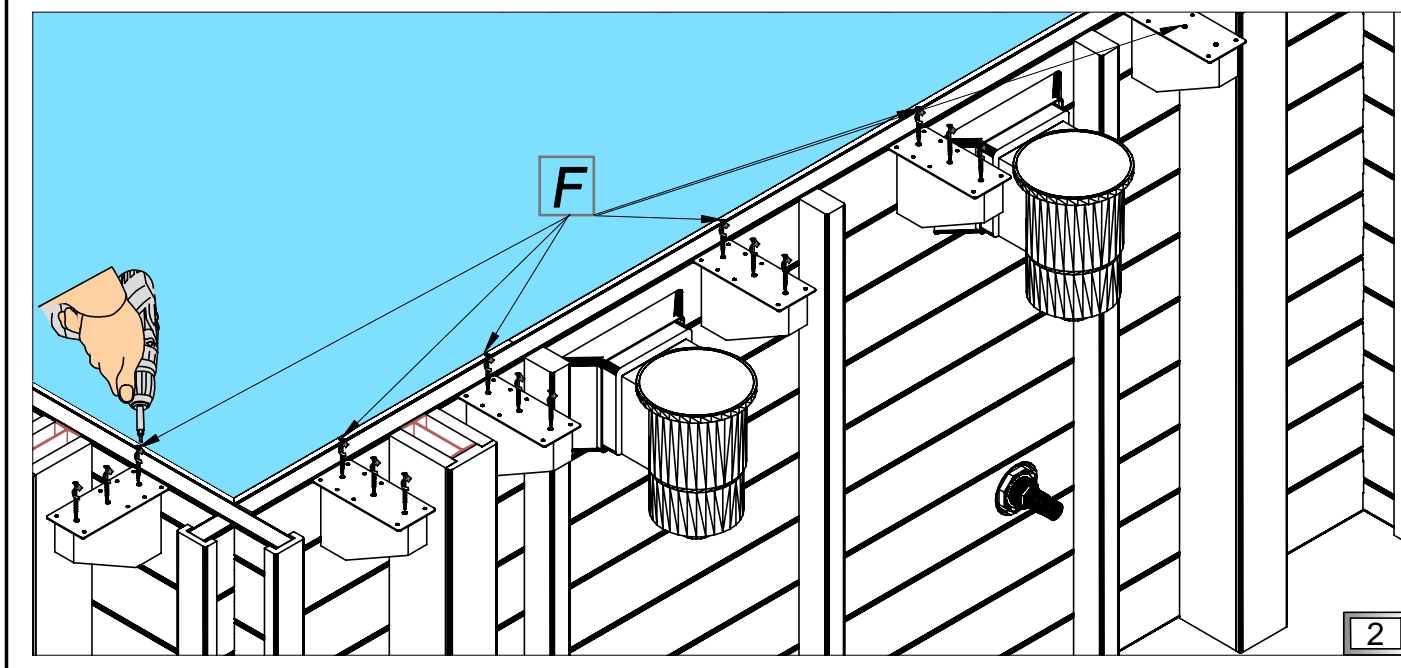
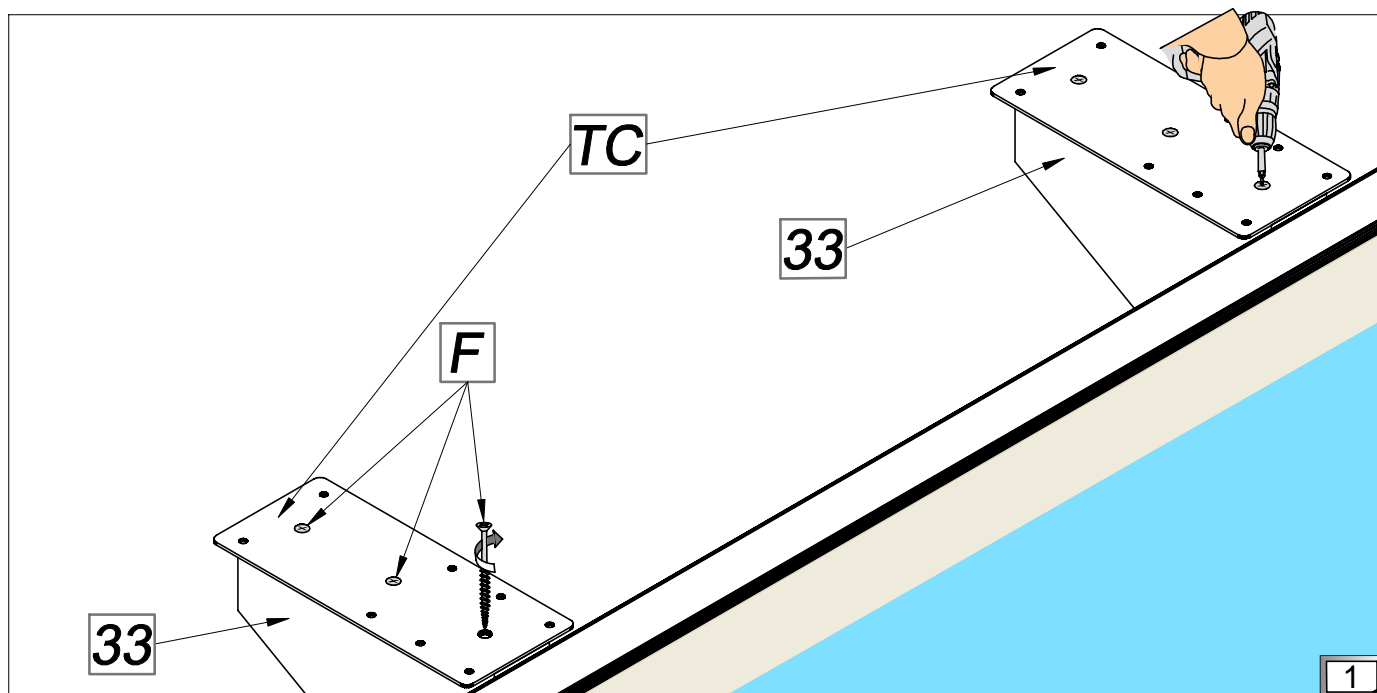

PL Taras

GB Terrace

DE Terrasse

FR Les margelles

NL Terras



- PL** Montaż desek tarasowych.
- FR** Montage des margelles.
- GB** Installation of terrace boards.
- DE** Installation der Terrassendielen.
- NL** Installatie van terrasplanken.

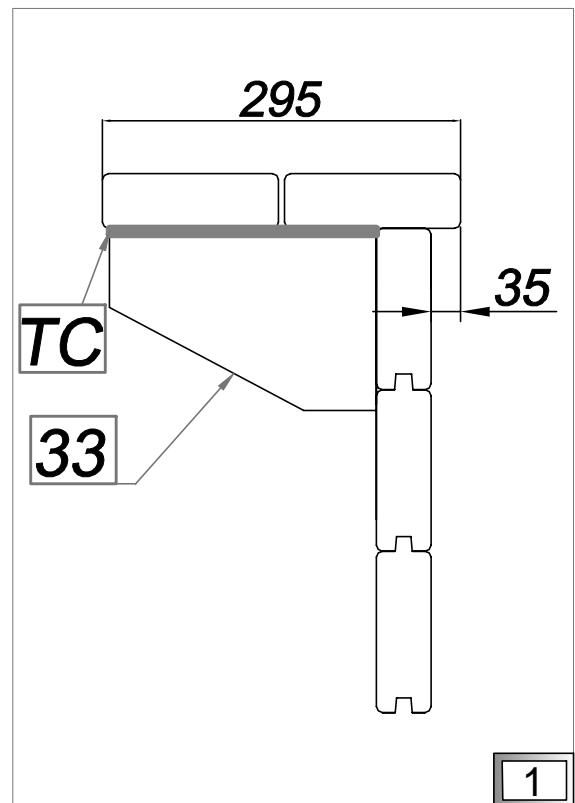
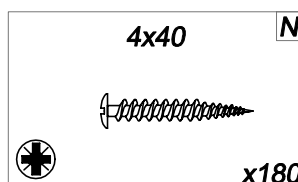
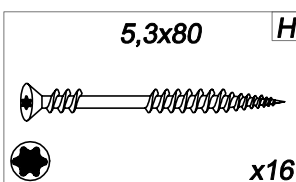
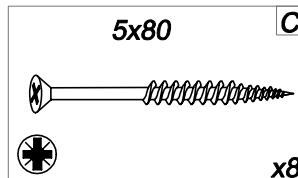
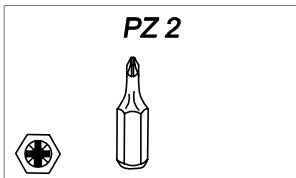
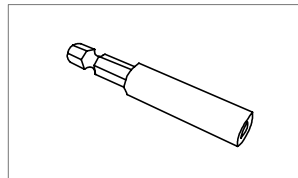
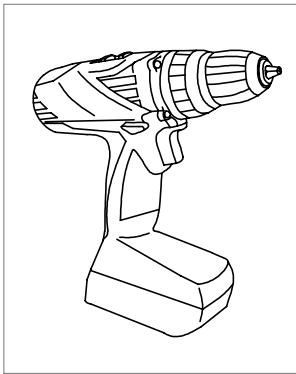
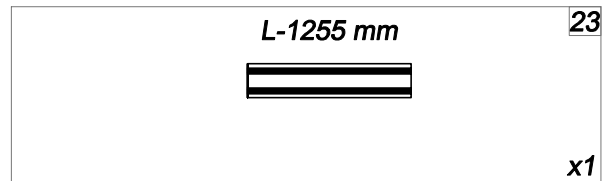
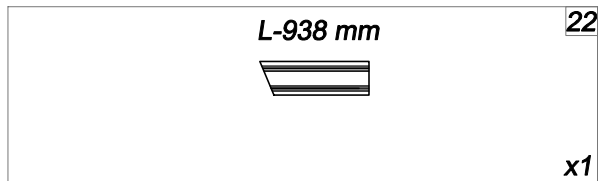
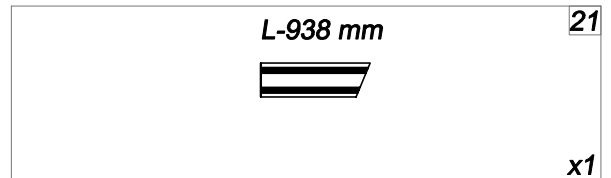
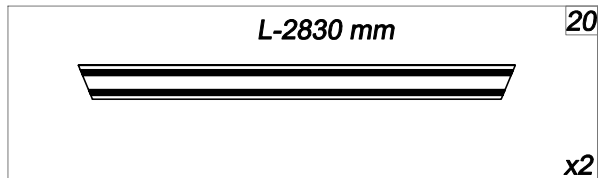
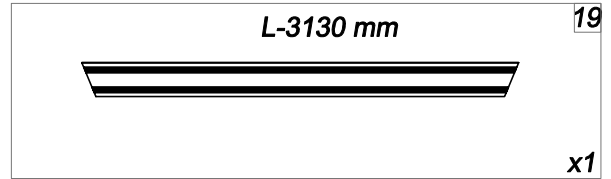
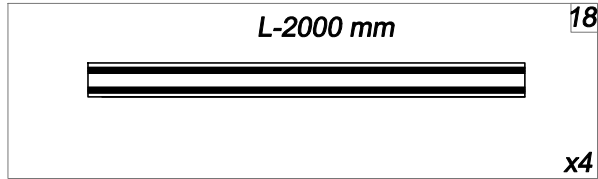
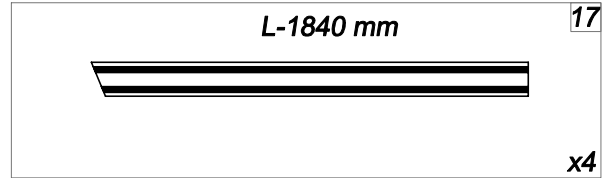
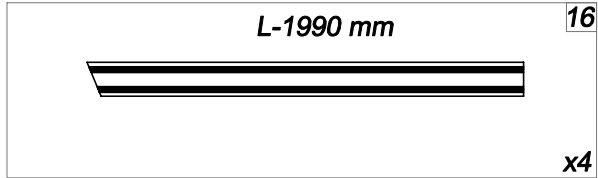

(A) Taras

(GB) Terrace

(DE) Terrasse

(FR) Les margelles

(NL) Terras



- (A)** Zamocuj deski tarsowe wedlug rysunku 2;3.
- (FR)** Monter les margelles suivant le dessin 2;3.
- (GB)** Mount terrace boards according to the drawing 2;3.
- (DE)** Montieren Sie die Terrassendielen gemäß der Zeichnung 2;3.
- (NL)** Monteer de terrasplanken volgens de tekening 2;3.

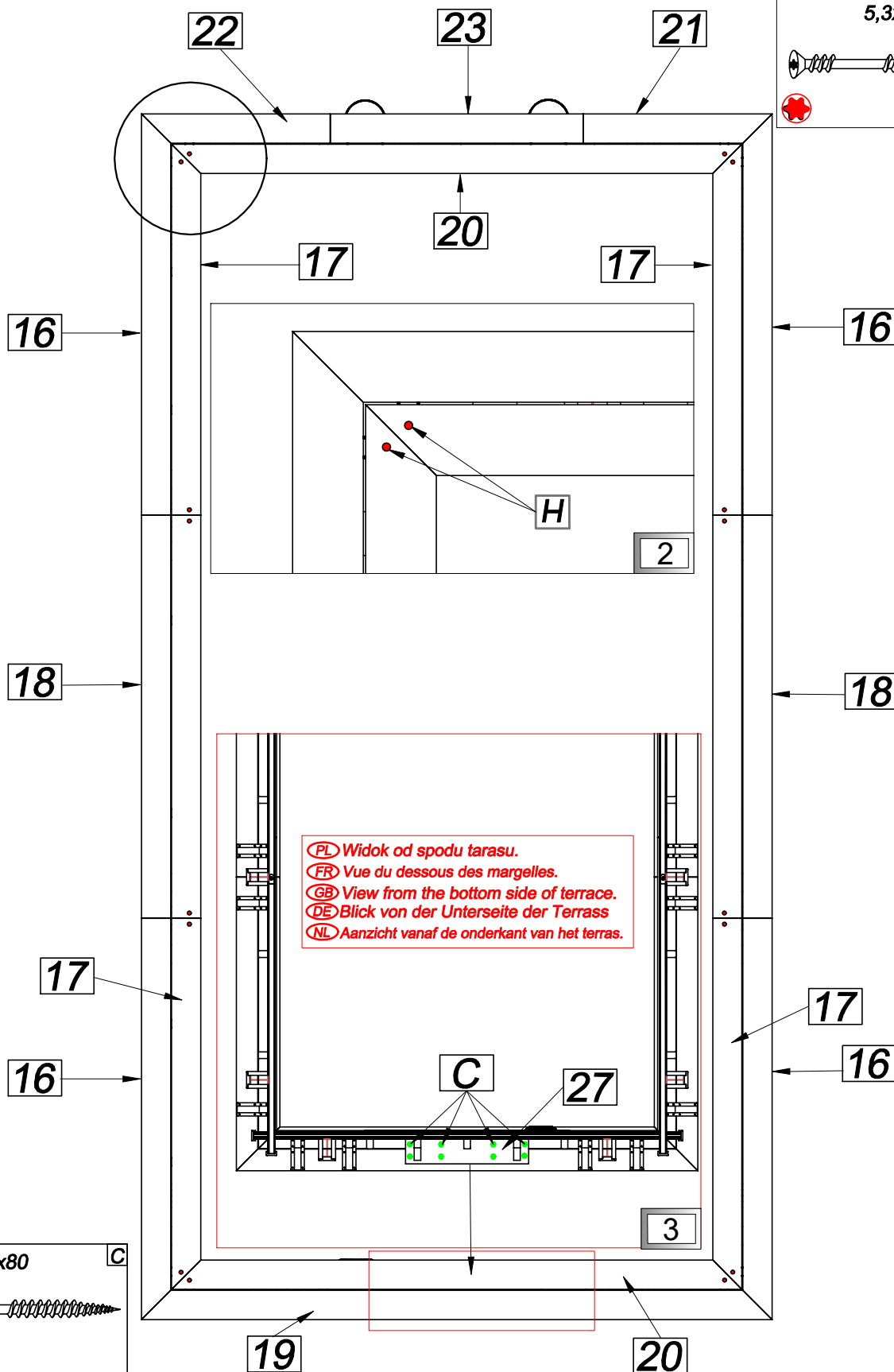

PL Taras

GB Terrace

DE Terrasse

FR Les margelles

NL Terras



PL Łącznik (TC) do tarasu montujemy od spodu.

FR Montez les connecteurs de terrasse (TC) sur le terrasse par le bas.

GB Mount terrace connectors (TC) to terrace from its bottom side.

DE Montieren Sie die Terrassenanschlüsse (TC) von unten an der Terrasse.

NL Monteer terrasconnectoren (TC) vanaf de onderkant op het terras.

4

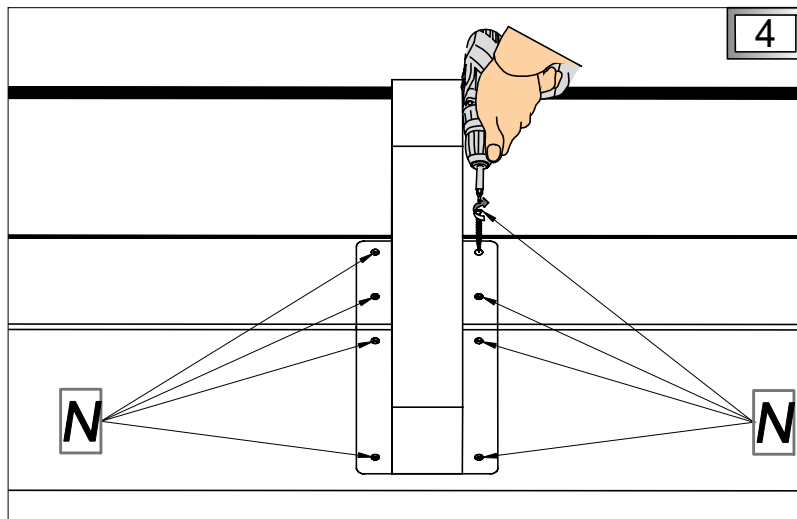

PL Widok od spodu tarasu.

FR Vue du dessous des margelles.

GB View from the bottom of terrace.

DE Blick von der Unterseite der Terrasse.

NL Aanzicht vanaf de onderkant van het terras.

5

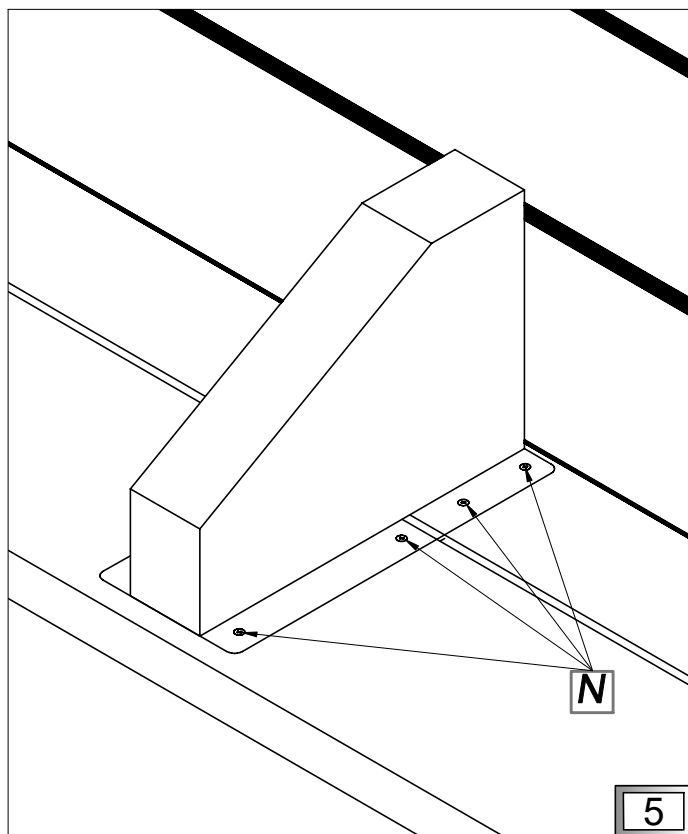

6

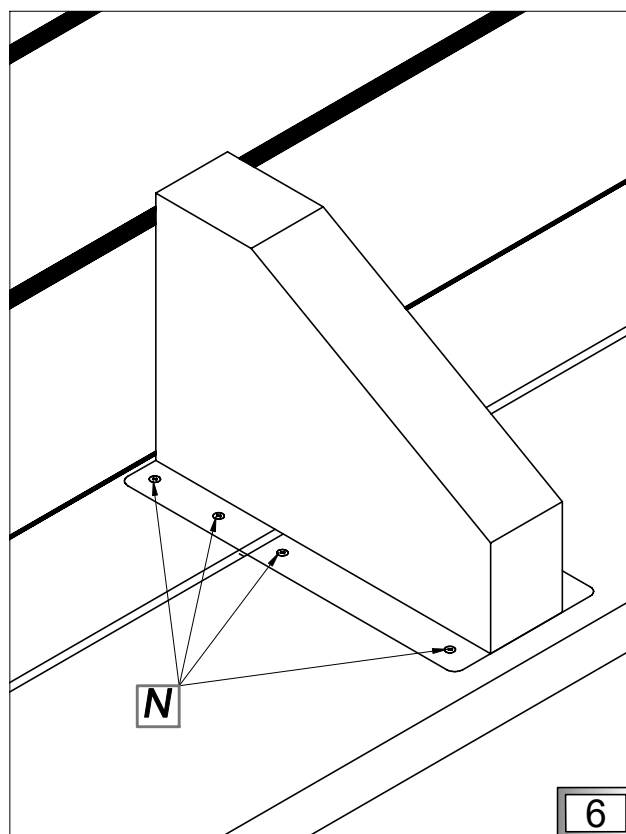

PL Taras

GB Terrace

DE Terrasse

FR Les margelles

NL Terras



- PL** Łącznik (TC) do tarasu montujemy od spodu.
- FR** Montez les connecteurs de terrasse (TC) sur le terrasse par le bas.
- GB** Mount terrace connectors (TC) to terrace from its bottom side.
- DE** Montieren Sie die Terrassenanschlüsse (TC) von unten an der Terrasse.
- NL** Monteer terrasconnectoren (TC) vanaf de onderkant op het terras.

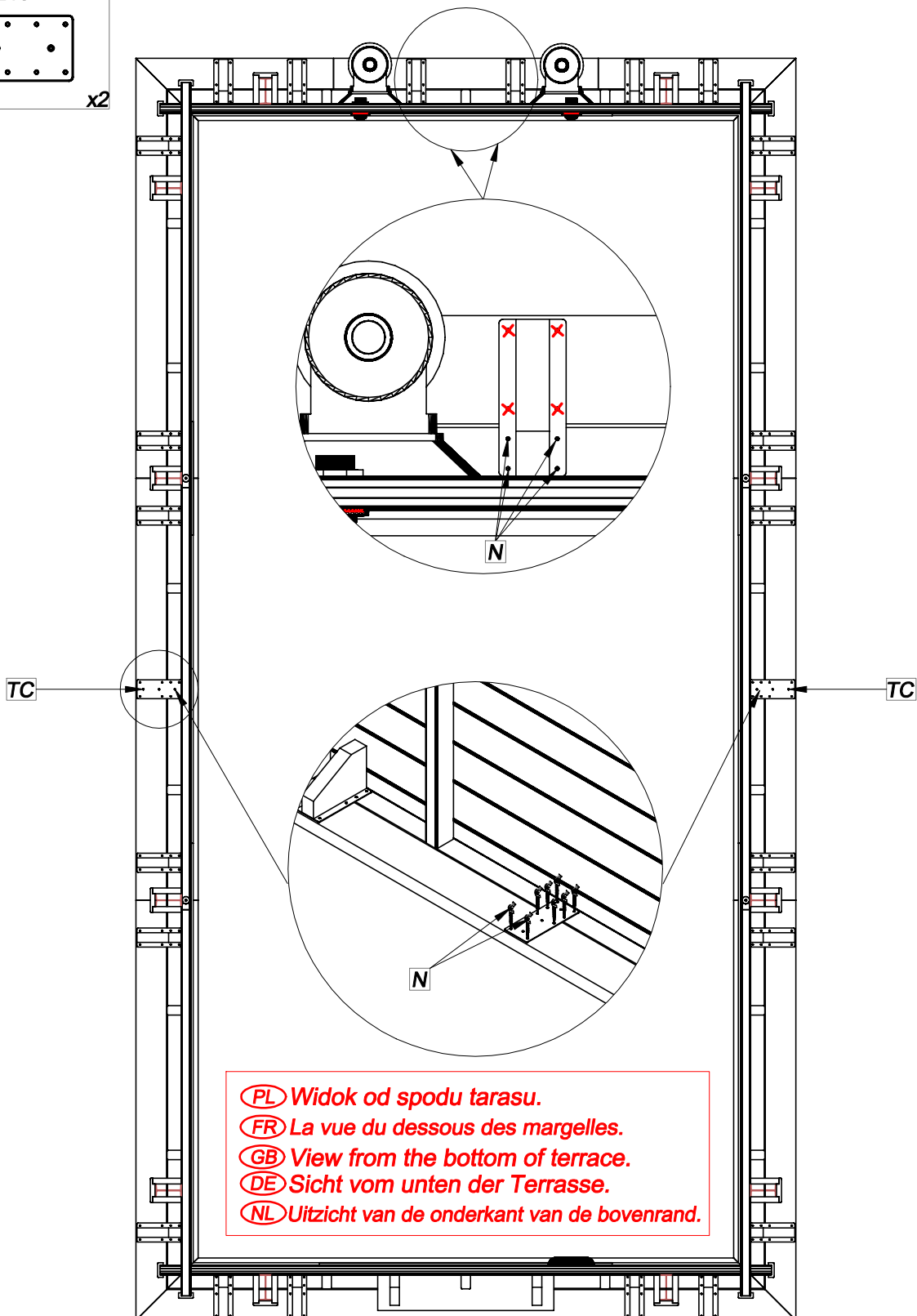
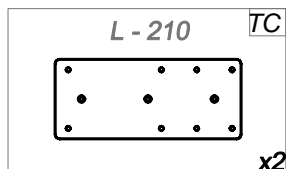

- PL** Widok od spodu tarasu.
- FR** La vue du dessous des margelles.
- GB** View from the bottom of terrace.
- DE** Sicht vom unten der Terrasse.
- NL** Uitzicht van de onderkant van de bovenrand.

(PL) Zawiasa tarasu skimmera
 (GB) Skimmer terrace hinge
 (DE) Skimmer Terrassenscharnier
(FR) Charnière de terrasse skimmer
 (NL) Skimmer terrasscharnier



(PL) Montaż zawiasy (A) tarasu skimmera.
(FR) Montez la charnière de terrasse du skimmer (A).
(GB) Mount the skimmer terrace hinge (A).
(DE) Montieren Sie das Scharnier der Skimmerterrasse (A).
(NL) Monteer het terrasscharnier van de skimmer (A).

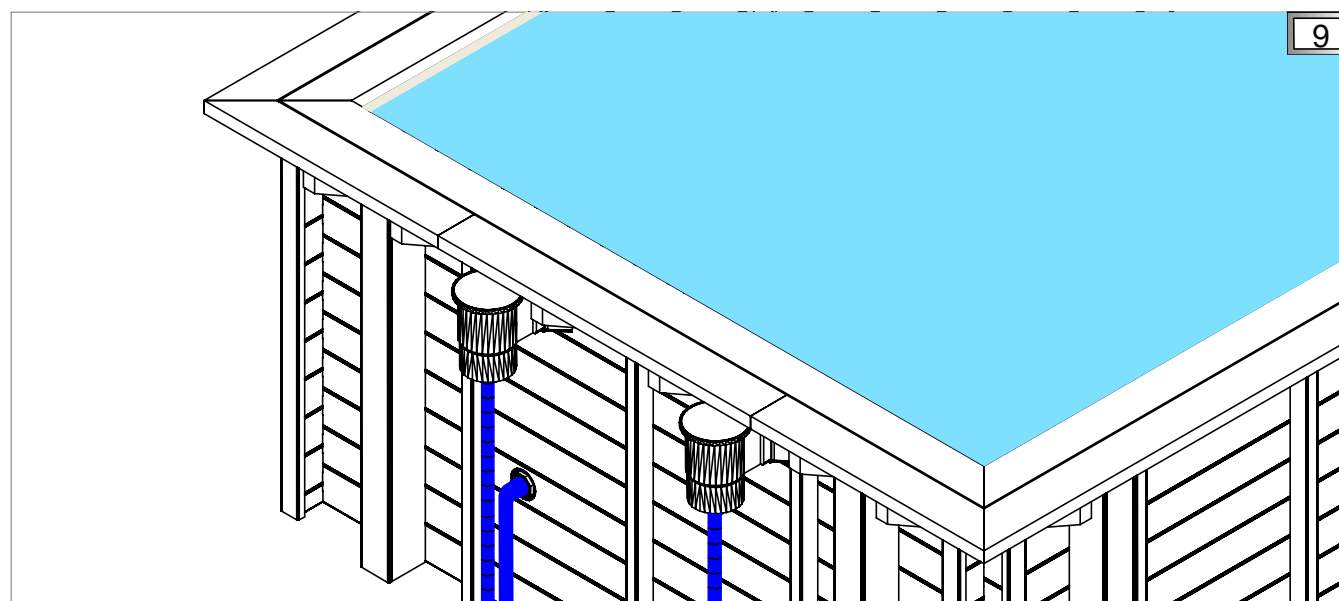
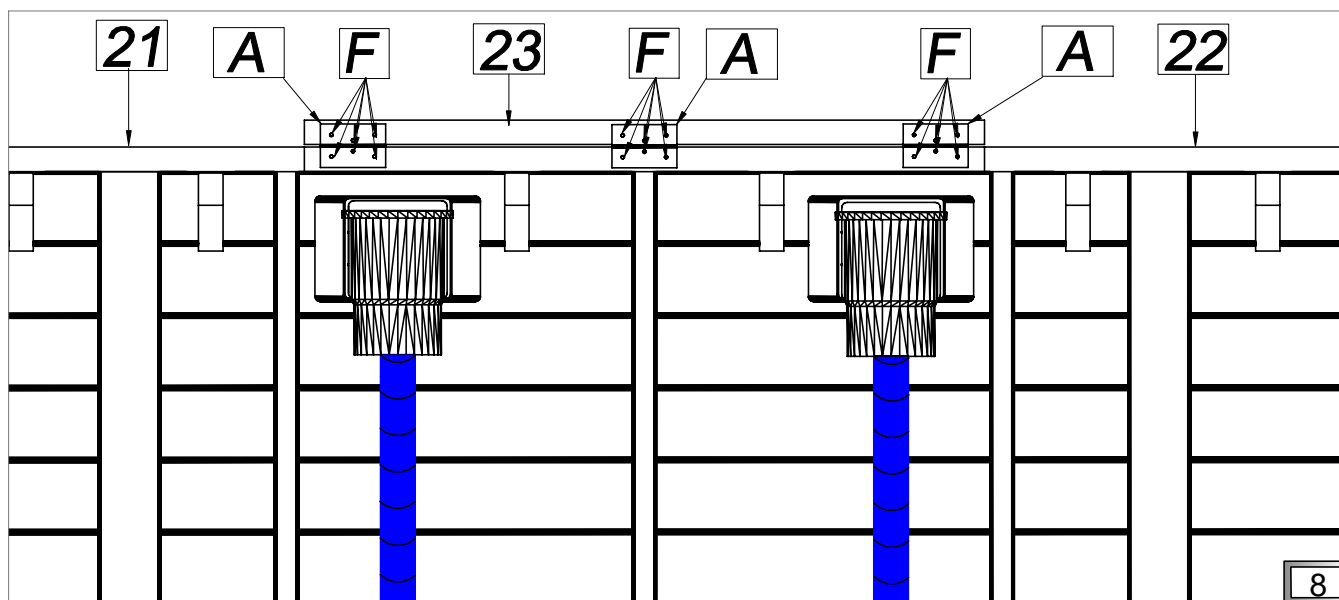
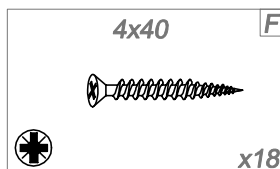
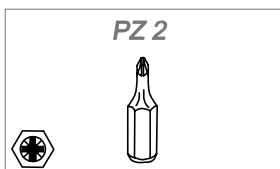
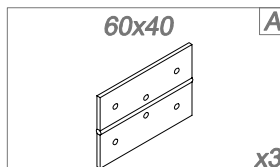
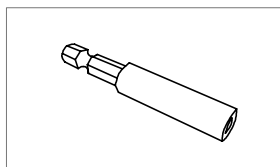
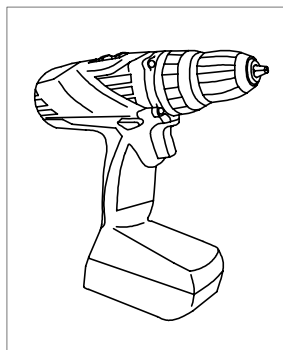

(PL) Struktura drewniana

(GB) Wooden structure

(DE) Holzstruktur

(FR) La structure bois

(NL) Houten structuur



(PL) Montaż łącznika caro (34) od spodu desek tarasowych.

(FR) Montage des jonctions (34) en dessous des margelles.

(GB) Installation of wooden connector (34) to the bottom of terrace boards.

(DE) Installation der hölzernen Verbindung (34) an die Unterseite der Terrassendielen.

(NL) Installatie van houten connector (34) aan de onderkant van terrasplanken.

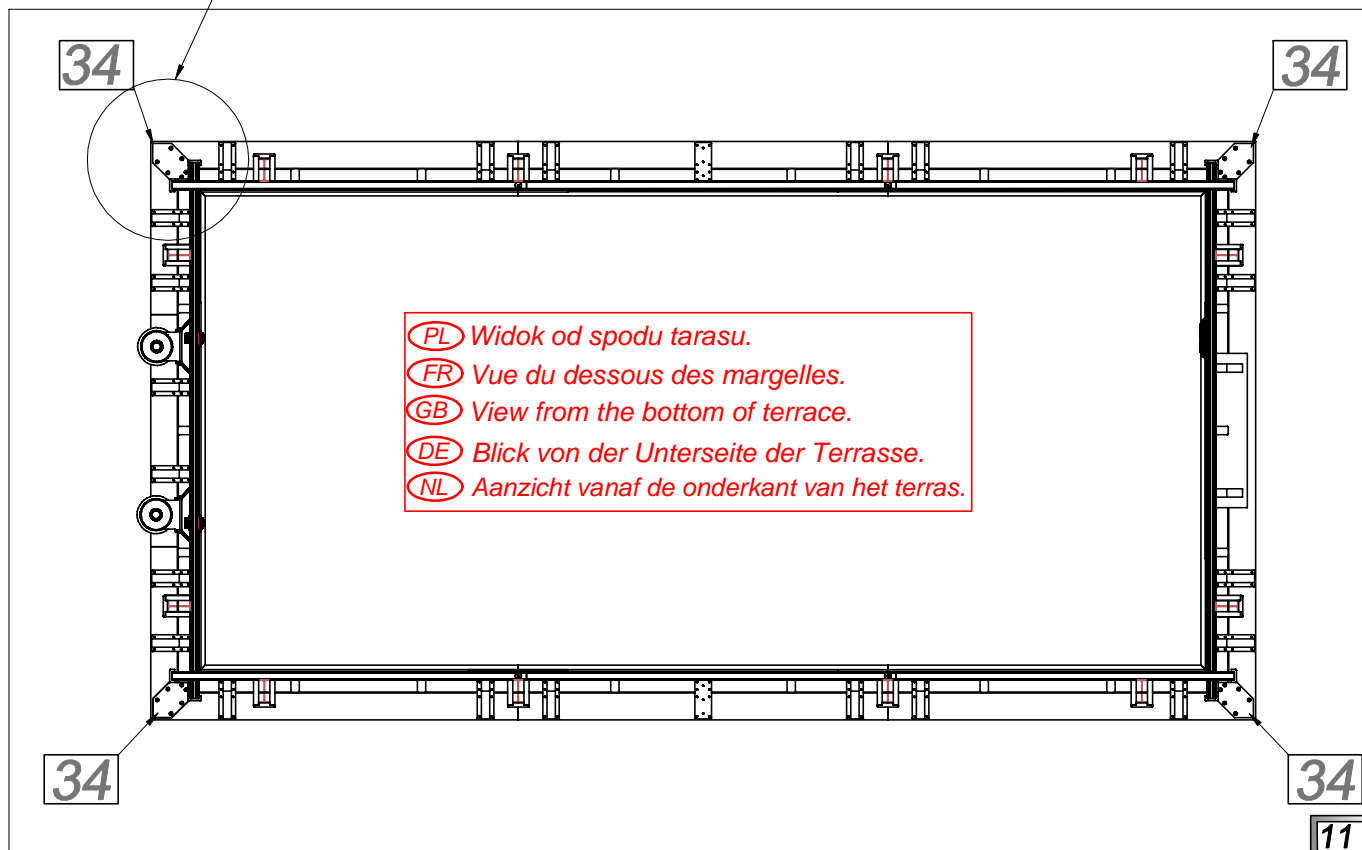
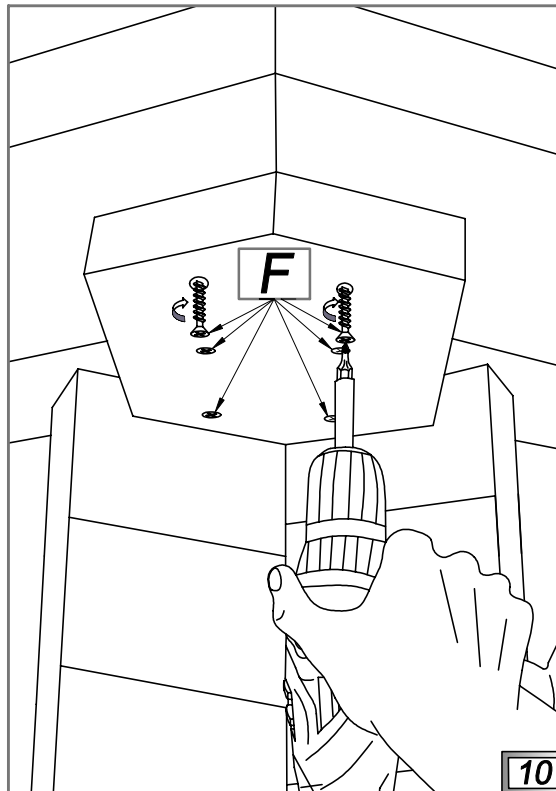
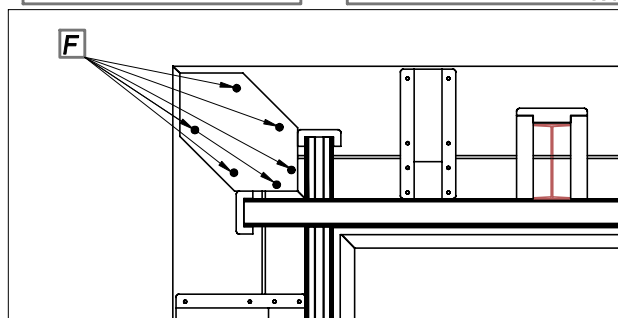
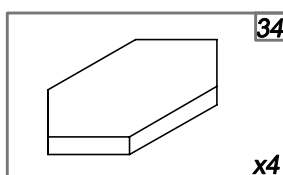
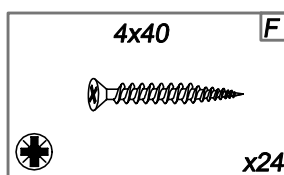
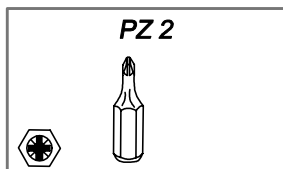
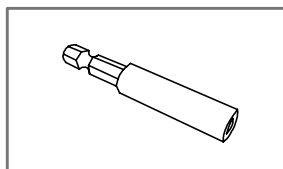
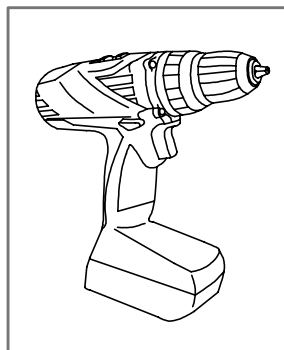

(PL) Schody drewniane

(GB) Wooden stairs

(DE) Hölzerne Treppen

(FR) L'escalier bois

(NL) Houten trap



- (PL)** Montaż schodów.
- (FR)** Montage de l'escalier.
- (GB)** Installation of stairs.
- (DE)** Installation der Treppen.
- (NL)** Installatie van de trap.

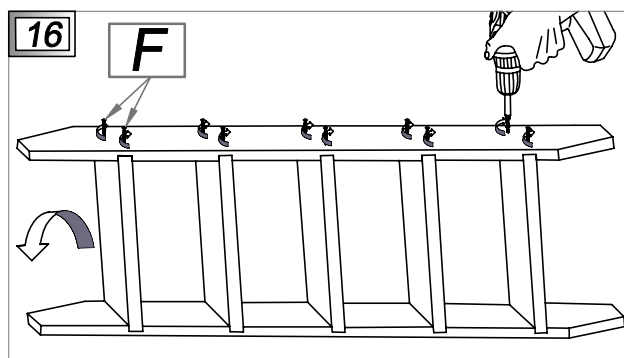
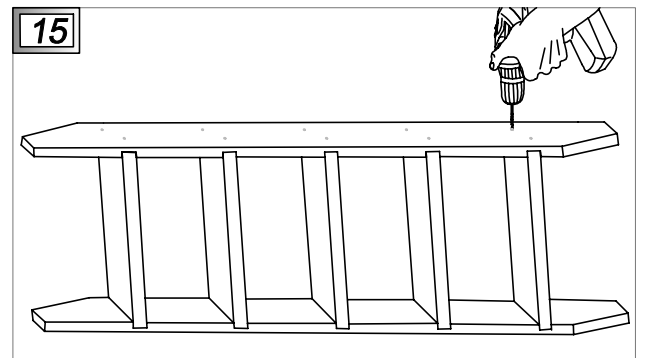
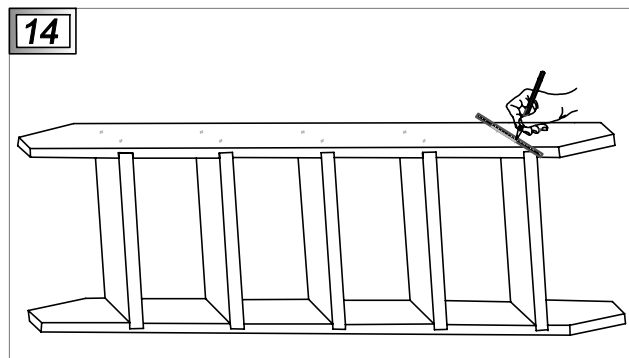
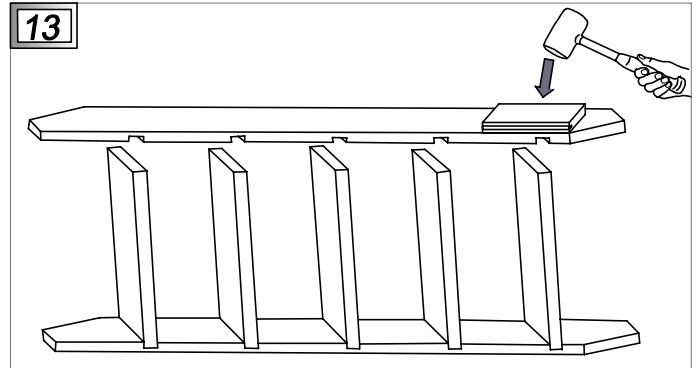
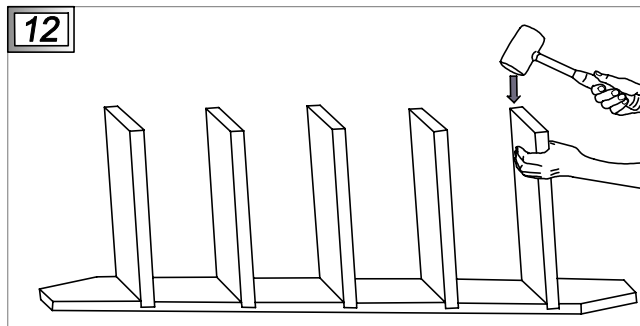
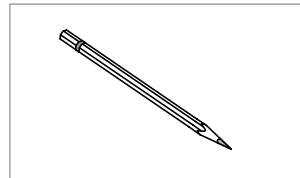
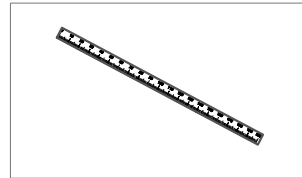
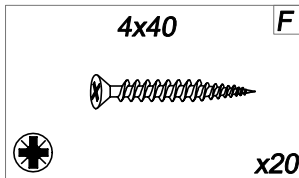
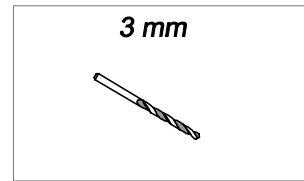
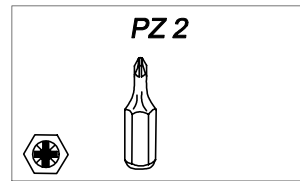
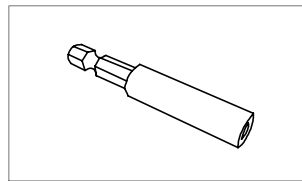
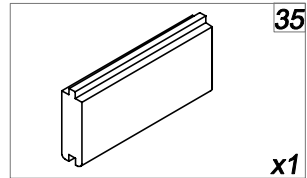
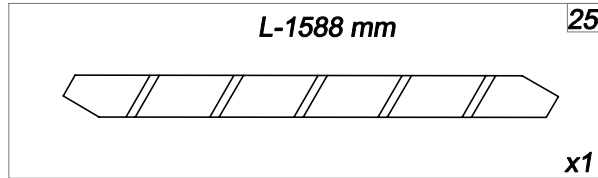
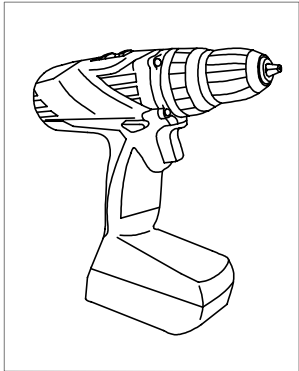
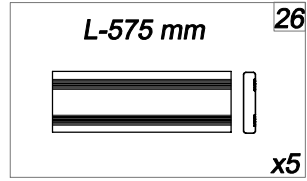
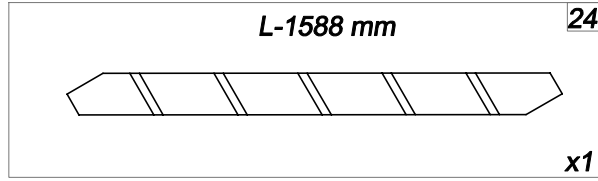
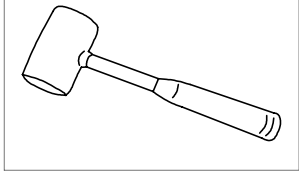

PL Schody drewniane

GB Wooden stairs

DE Hölzerne Treppen

FR L'escalier bois

NL Houten trap



PL Montaż zawieszki (B1, B2). Schody mocujemy na ścianie ze wspornikiem schodów (27).

FR Le montage des crochets et des gâches (B1, B2). Fixez l'escalier sur la paroi avec le renfort d'escalier (27).

GB Installation of tag and hook kit (B1, B2). Stairs are mounted on the wall with stairs support (27).

DE Installation der Aufhänger und des Haken-Satzes (B1, B2). Treppen sind an der Wand mit Treppen-Unterstützung montiert (27).

NL Installatie van het inhaak systeem (B1, B2). Trap wordt aan de bovenrand gemonteerd (27).

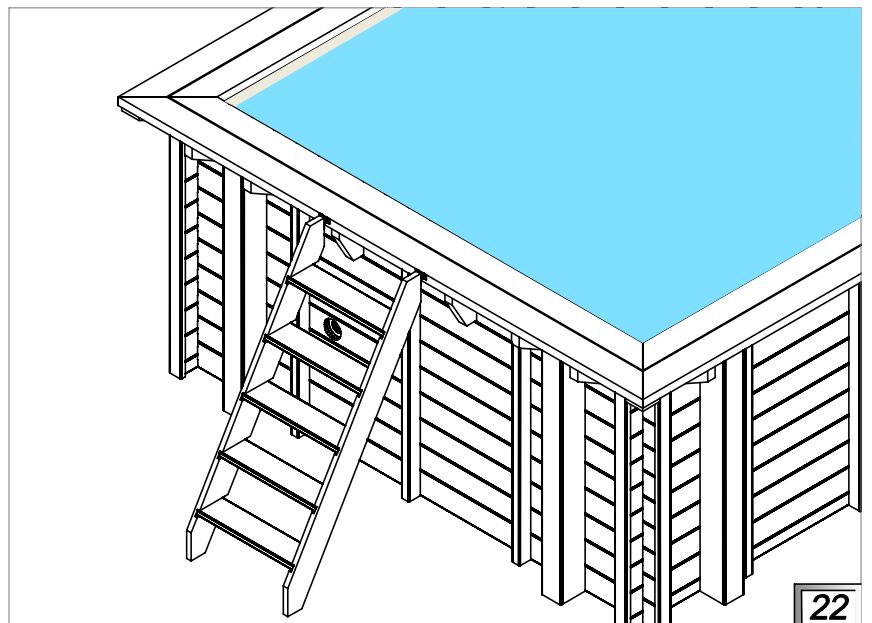
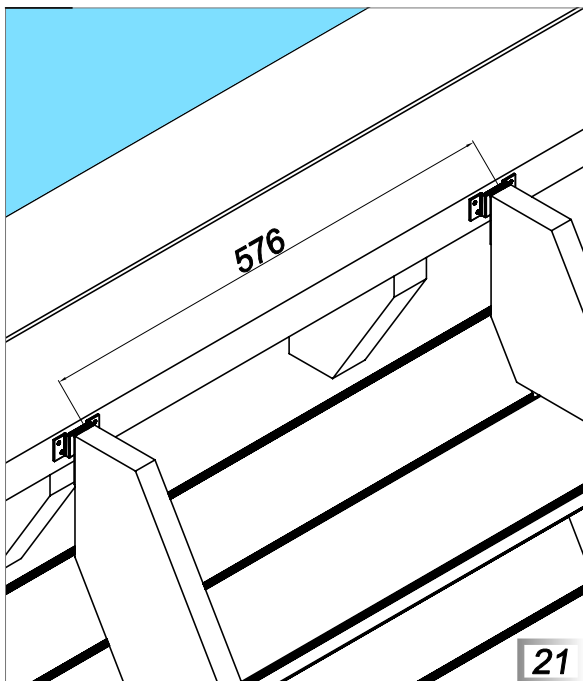
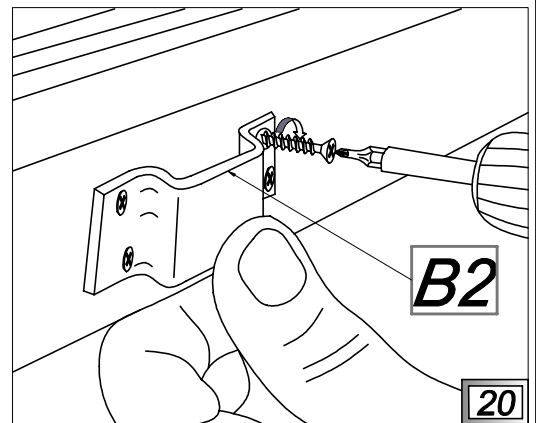
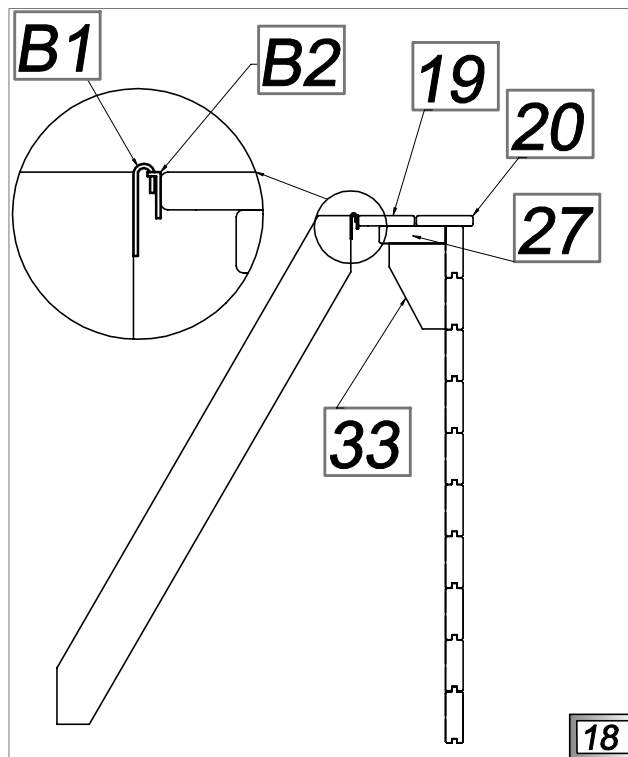
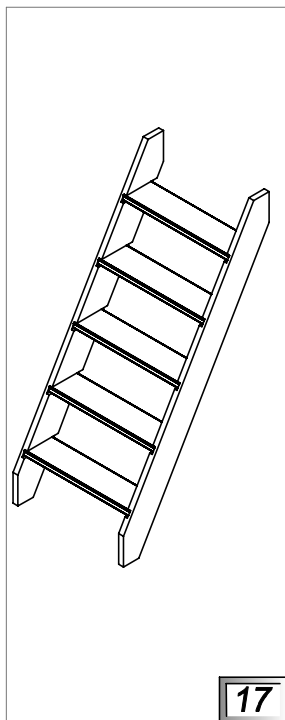
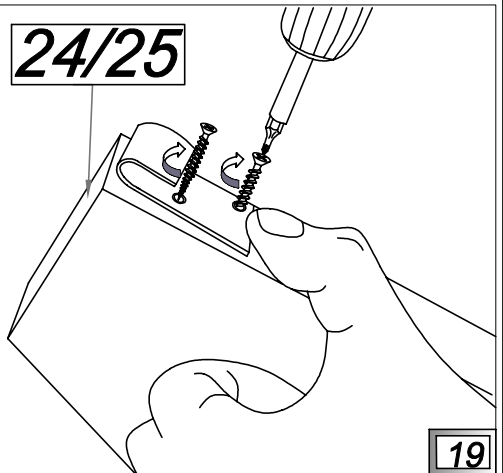
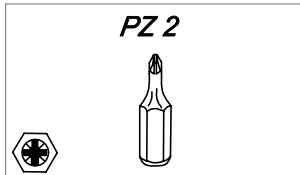
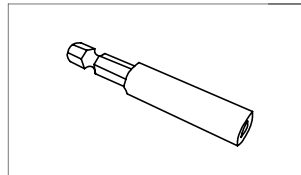
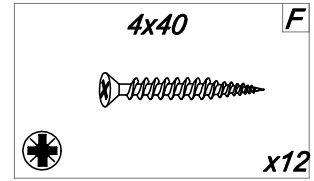
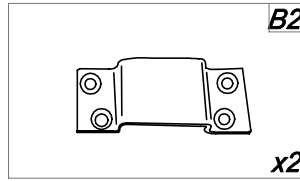
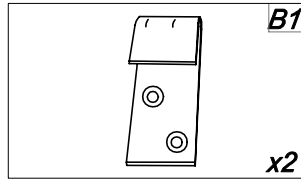
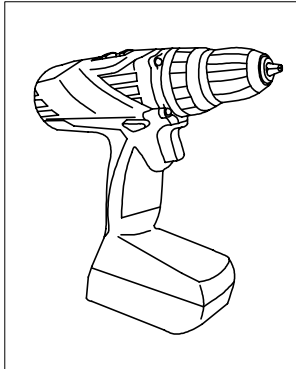

PL Drabinka stalowa

GB Stainless steel ladder

DE Leiter aus Edelstahl

FR L'échelle inox

NL Roestvrijstalen ladder



PL Montaż stalowej drabinki wewnętrznej do desek tarasowych.

FR Fixation de l'échelle inox aux margelles.

GB Mounting stainless steel ladder to the terrace boards.

DE Montage der Edelstahlleiter an die Terrassendielen.

NL Montage van roestvrijstalen ladder op de terrasplanken.

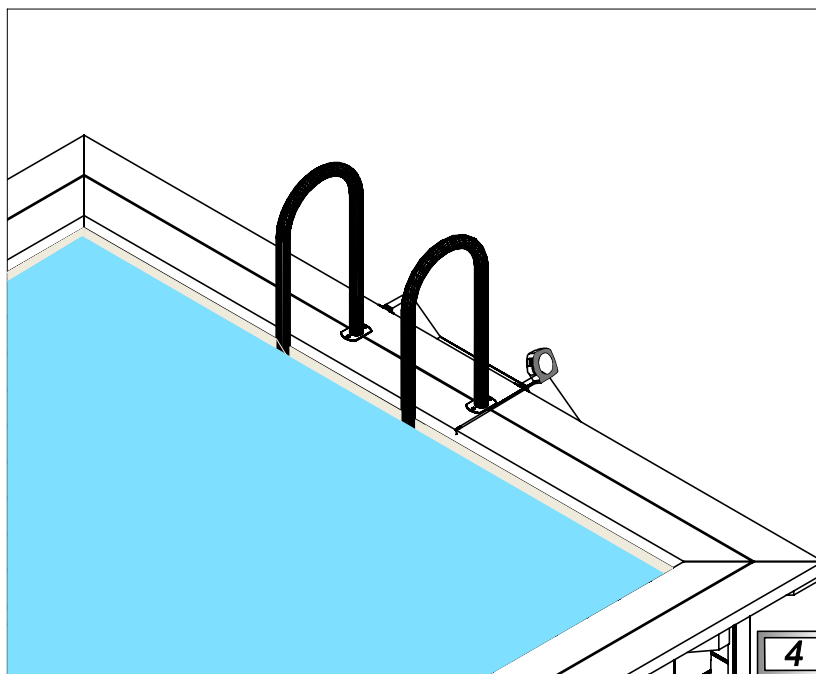
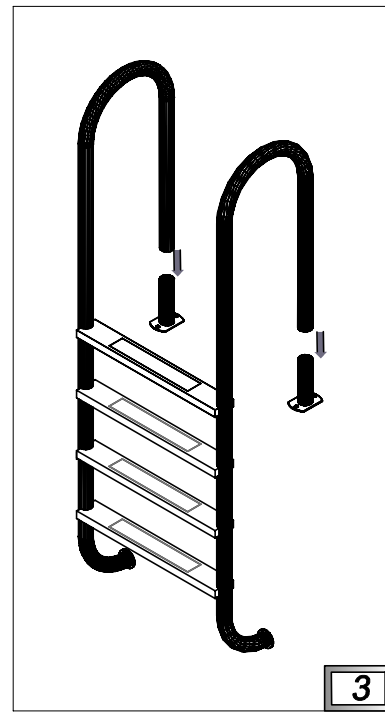
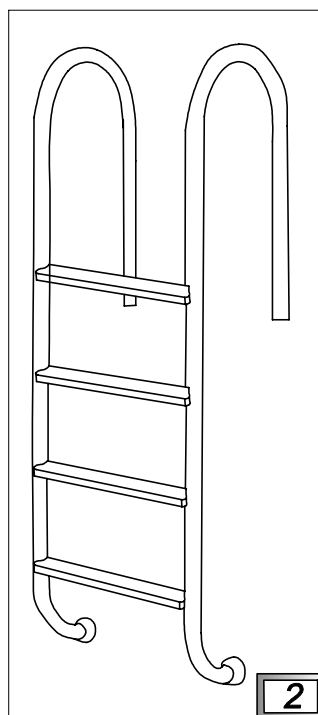
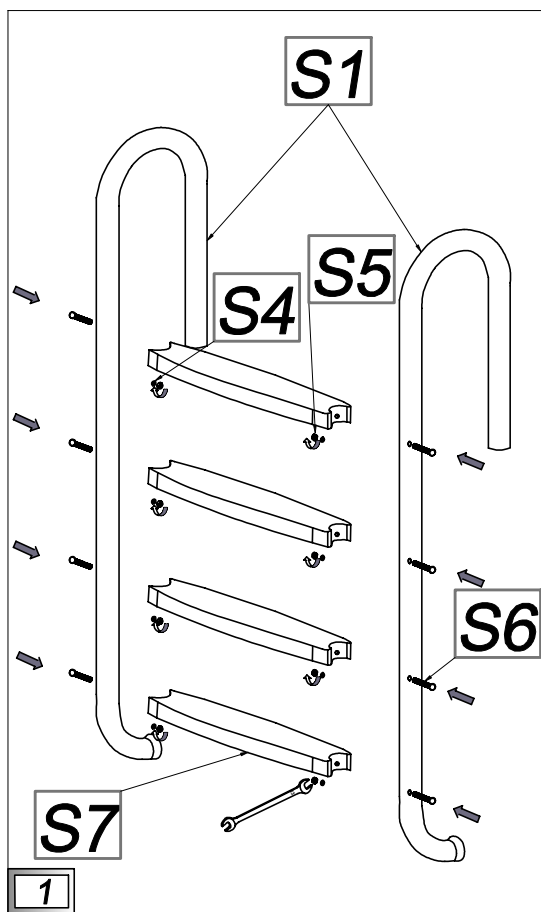
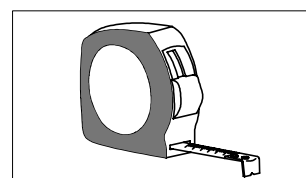
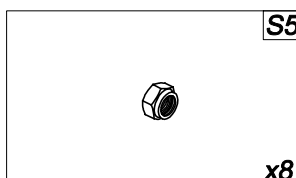
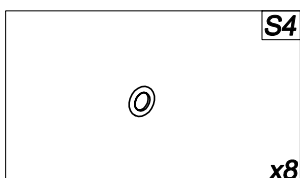
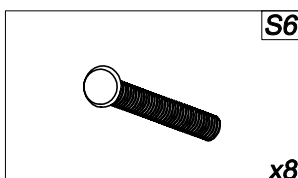
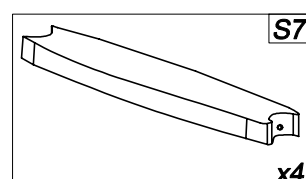
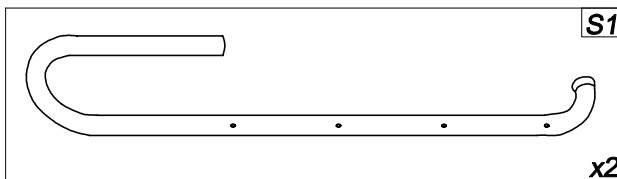
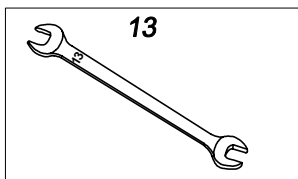

PL Drabinka stalowa

GB Stainless steel ladder

DE Leiter aus Edelstahl

FR L'échelle inox

NL Roestvrijstalen ladder



PL Montaż stalowej drabinki wewnętrznej do desek tarasowych, przygotowanie otworów.

FR Montage d'une échelle en acier inoxydable sur des planches de terrasse. Préparez les trous de montage.

GB Mounting stainless steel ladder to terrace boards. Prepare mounting holes.

DE Edelstahlleiter auf Terrassenbrettern montieren. Montagebohrungen vorbereiten.

NL Montage van roestvrijstalen op terrasplanken. Montagegaten voorbereiden.

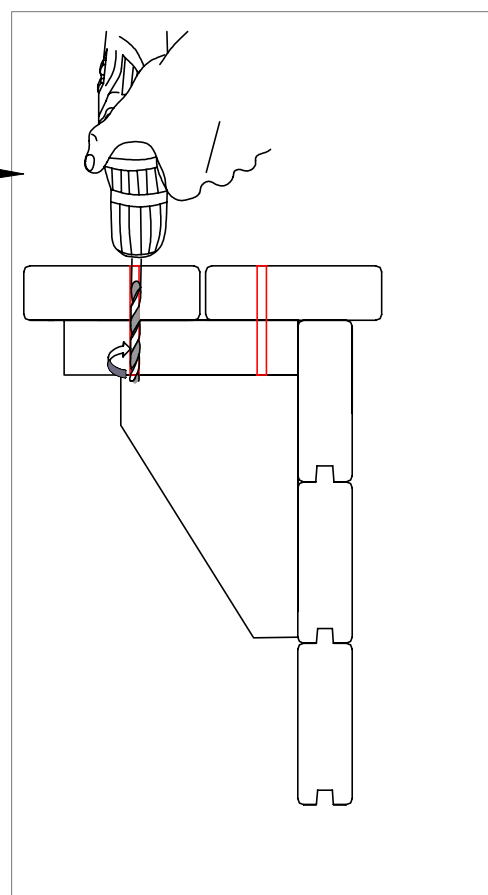
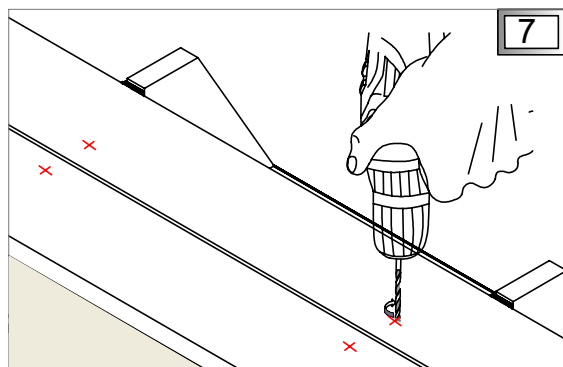
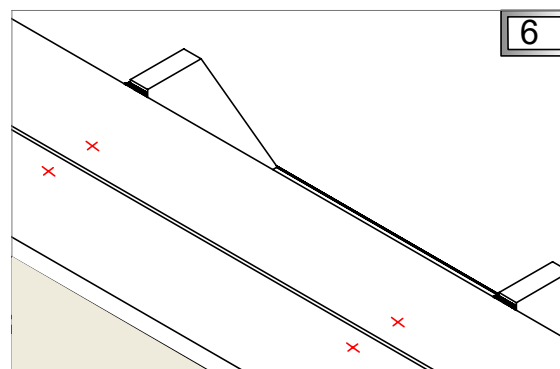
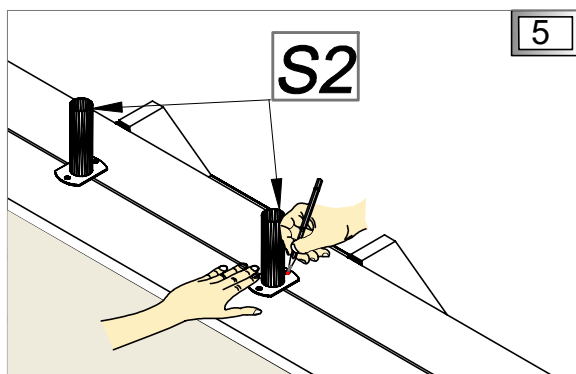
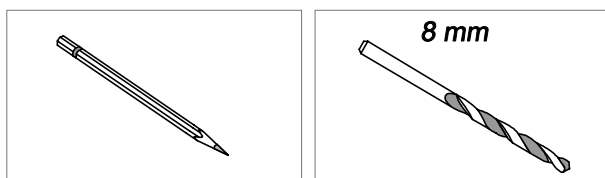
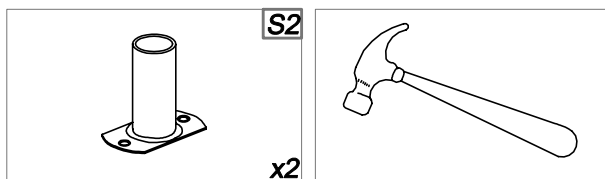
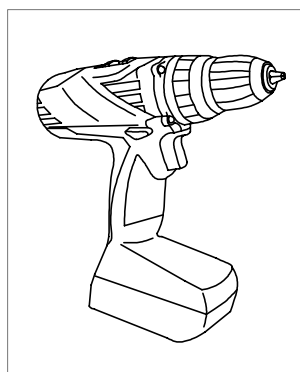

PL Otwór wykonać na przelot w celu wprowadzenie okucia S8 i S9

FR Faire un trou dans les planches pour y mettre les raccords S8 et S9

GB Make a hole through boards to put in the fittings S8 and S9

DE Machen Sie ein Loch durch die Bretter, um die Armaturen S8 und S9 einzusetzen

NL Maak een gat door de planken om de fittingen S8 en S9 te plaatsen.

PL Drabinka stalowa

GB Stainless steel ladder

DE Leiter aus Edelstahl

FR L'échelle inox

NL Roestvrijstalen ladder



- PL** Montaż stalowej drabinki wewnętrznej do desek tarasowych.
- FR** Fixation de l'échelle inox aux margelles.
- GB** Mounting stainless steel ladder to the terrace boards.
- DE** Montage der Edelstahlleiter an die Terrassendielen
- NL** Montage van roestvrijstalen ladder op de terrasplanken.

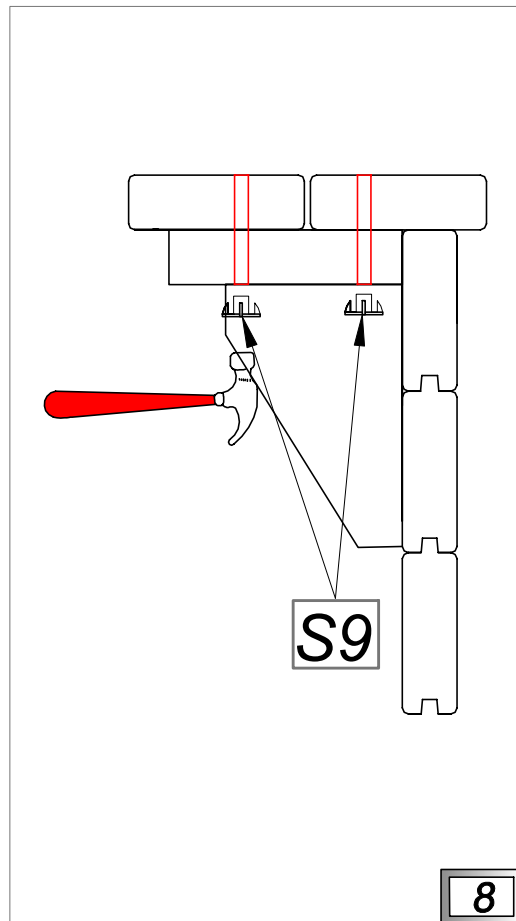
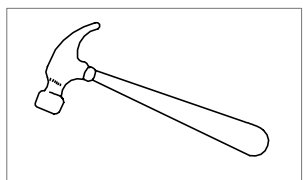
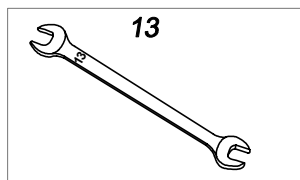
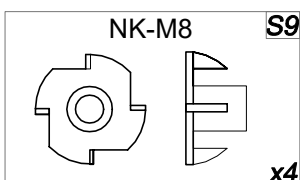
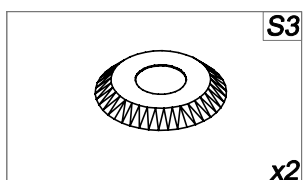
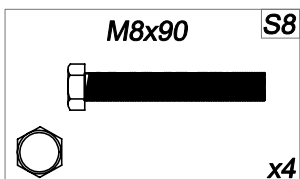
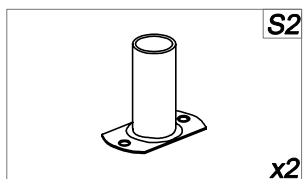
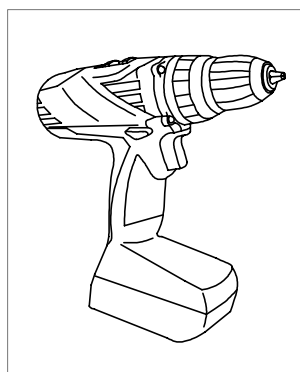

- PL** Widok od spodu tarasu.
- FR** Vue du dessous des margelles.
- GB** View from the bottom of terrace.
- DE** Blick von der Unterseite der Terrasse.
- NL** Aanzicht vanaf de onderkant van het terras.

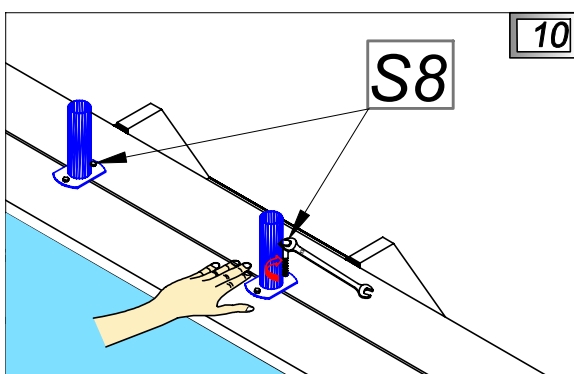
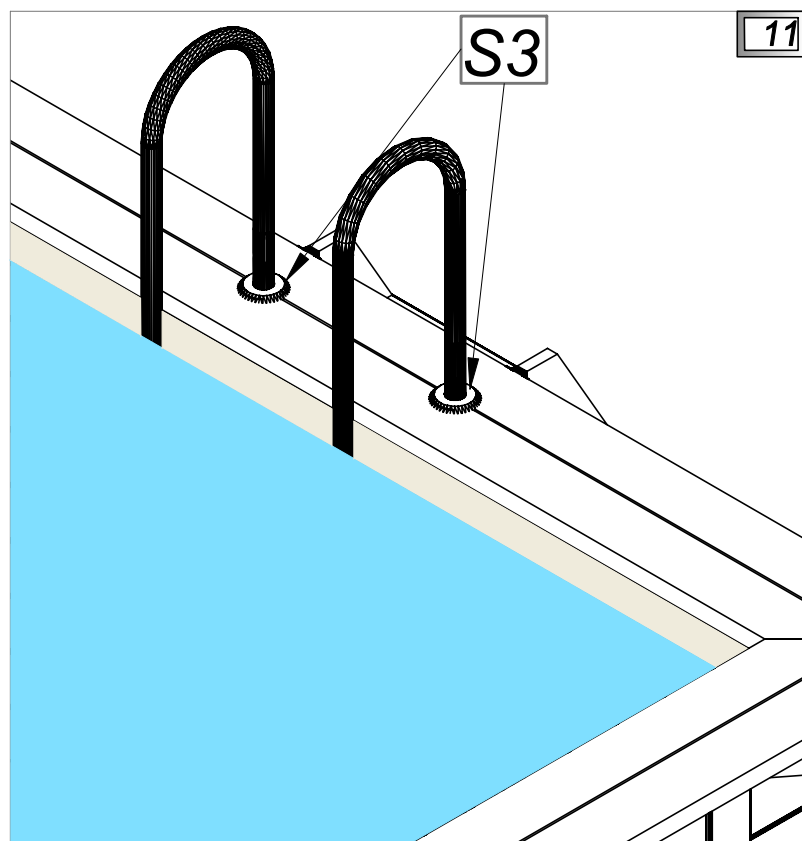
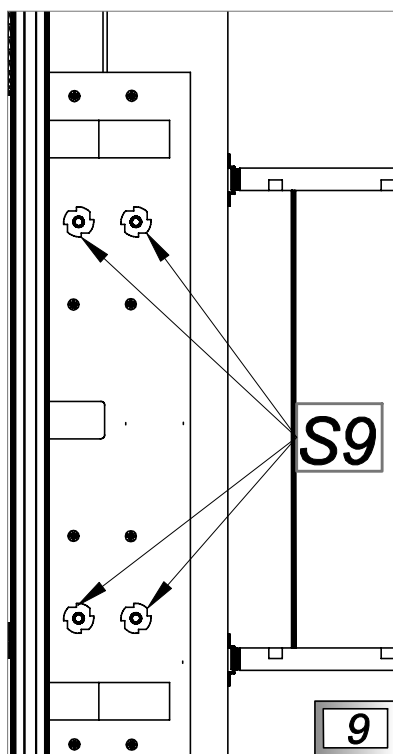

PL Maskownice

GB Corners covers

DE Eck-Abdeckungen

FR Les caches

NL Covers voor de hoeken



- PL** Montaż maskownic (Y) do desek tarasowych.
- FR** Montage des caches (Y) pour les margelles.
- GB** Mounting covers (Y) for corners of terrace boards.
- DE** Montage der Abdeckungen (Y) ans Terrassenholz.
- NL** Montage van covers (Y) voor de hoeken van de terrasplanken.

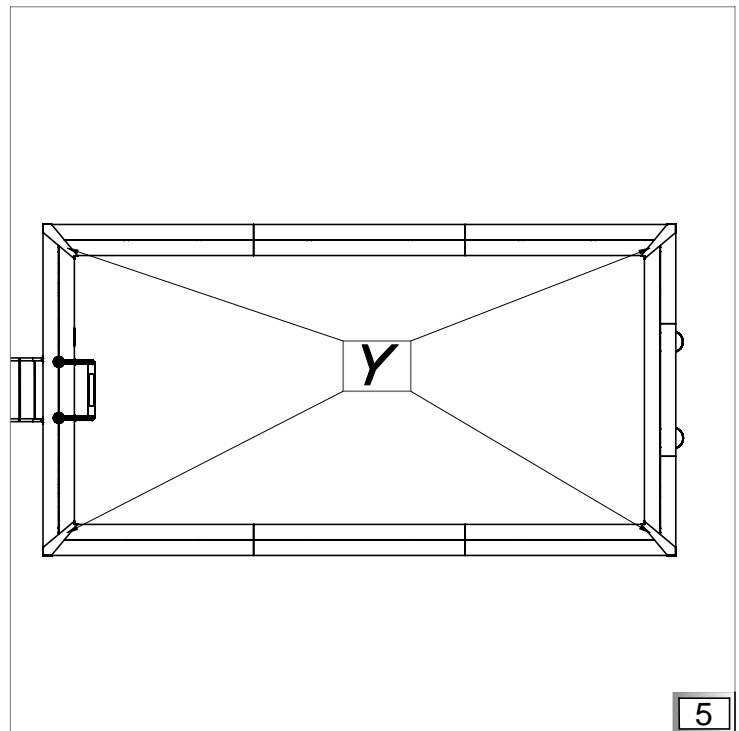
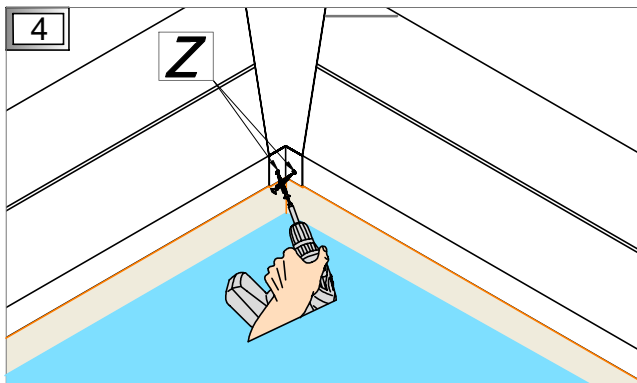
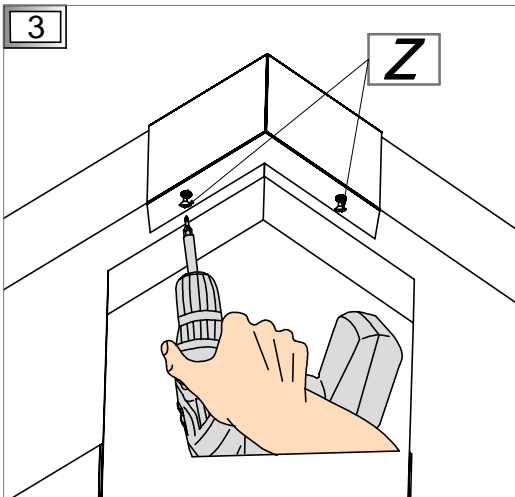
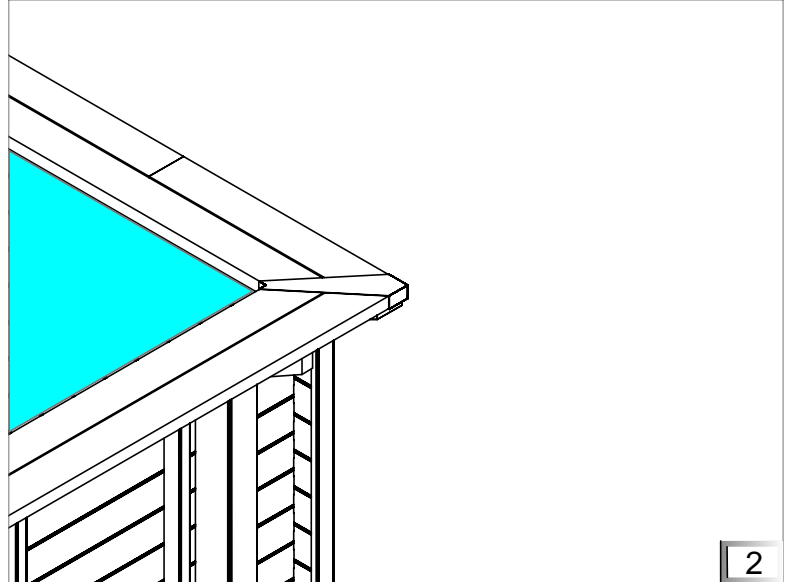
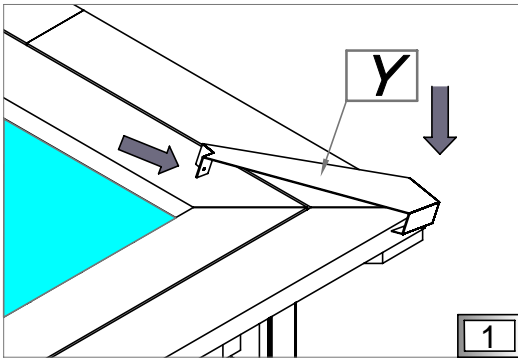
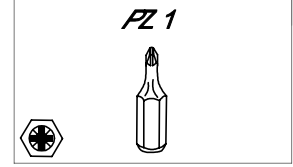
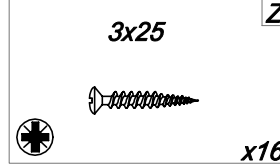
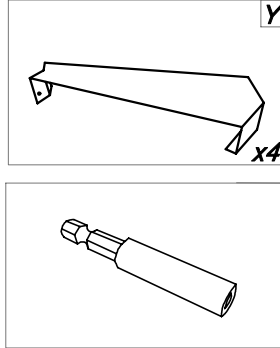
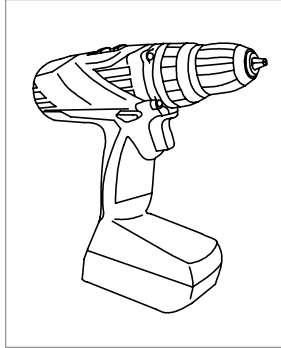

PL Maskownice

GB Corners covers

DE Eck-Abdeckungen

FR Les caches

NL Covers voor de hoeken



- PL** Montaż maskownic (X) do desek tarasowych.
- FR** Montage des caches (X) pour les margelles.
- GB** Mounting covers (X) for corners of terrace boards.
- DE** Montage der Abdeckungen (X) ans Terrassenholz.
- NL** Montage van covers (X) voor de hoeken van de terrasplanken.

